



**NONRESIDENT  
TRAINING  
COURSE**

February 2002



---

# **Aviation Electricity and Electronics—Maintenance Fundamentals**

**NAVEDTRA 14318**

**NOTICE**

Page 4-22 must be printed on a COLOR printer.

**DISTRIBUTION STATEMENT A: Approved for public release; distribution is unlimited.**

**Although the words “he,” “him,” and “his” are used sparingly in this course to enhance communication, they are not intended to be gender driven or to affront or discriminate against anyone.**

**DISTRIBUTION STATEMENT A: Approved for public release; distribution is unlimited.**

# PREFACE

By enrolling in this self-study course, you have demonstrated a desire to improve yourself and the Navy. Remember, however, this self-study course is only one part of the total Navy training program. Practical experience, schools, selected reading, and your desire to succeed are also necessary to successfully round out a fully meaningful training program.

**COURSE OVERVIEW:** Provides basic information on mathematics, physics, maintenance and troubleshooting, and common test equipment.

**THE COURSE:** This self-study course is organized into subject matter areas, each containing learning objectives to help you determine what you should learn along with text and illustrations to help you understand the information. The subject matter reflects day-to-day requirements and experiences of personnel in the rating or skill area. It also reflects guidance provided by Enlisted Community Managers (ECMs) and other senior personnel, technical references, instructions, etc., and either the occupational or naval standards, which are listed in the *Manual of Navy Enlisted Manpower Personnel Classifications and Occupational Standards*, NAVPERS 18068.

**THE QUESTIONS:** The questions that appear in this course are designed to help you understand the material in the text.

**VALUE:** In completing this course, you will improve your military and professional knowledge. Importantly, it can also help you study for the Navy-wide advancement in rate examination. If you are studying and discover a reference in the text to another publication for further information, look it up.

*2002 Edition Prepared by  
ATCS(AW) John Linzer  
and  
ATC(AW) Bryan Slycord*

Published by  
NAVAL EDUCATION AND TRAINING  
PROFESSIONAL DEVELOPMENT  
AND TECHNOLOGY CENTER

**NAVSUP Logistics Tracking Number  
0504-LP-100-4095**

## **Sailor's Creed**

"I am a United States Sailor.

I will support and defend the Constitution of the United States of America and I will obey the orders of those appointed over me.

I represent the fighting spirit of the Navy and those who have gone before me to defend freedom and democracy around the world.

I proudly serve my country's Navy combat team with honor, courage and commitment.

I am committed to excellence and the fair treatment of all."

# TABLE OF CONTENTS

<b>CHAPTER</b>	<b>PAGE</b>
1. Mathematics - Basics .....	1-1
2. Mathematics - Applications .....	2-1
3. Physics - Basics.....	3-1
4. Physics - Applications.....	4-1
5. Maintenance and Troubleshooting .....	5-1
6. Common Test Equipment .....	6-1
 <b>APPENDIX</b>	
I. Glossary .....	AI-1
II. Reference List .....	AII-1
III. Squares, Cubes, Square Roots, Cube Roots, Logarithms, and Reciprocals of Numbers .....	AIII-1
IV. Natural Sines, Cosines, and Tangents of Angles from $0^\circ$ to $90^\circ$ .....	AIV-1
V. Mathematical Symbols.....	AV-1
VI. Formulas.....	AVI-1
VII. Weights and Measures .....	AVII-1
<b>INDEX</b> .....	<b>INDEX-1</b>

# INSTRUCTIONS FOR TAKING THE COURSE

## ASSIGNMENTS

The text pages that you are to study are listed at the beginning of each assignment. Study these pages carefully before attempting to answer the questions. Pay close attention to tables and illustrations and read the learning objectives. The learning objectives state what you should be able to do after studying the material. Answering the questions correctly helps you accomplish the objectives.

## SELECTING YOUR ANSWERS

Read each question carefully, then select the BEST answer. You may refer freely to the text. The answers must be the result of your own work and decisions. You are prohibited from referring to or copying the answers of others and from giving answers to anyone else taking the course.

## SUBMITTING YOUR ASSIGNMENTS

To have your assignments graded, you must be enrolled in the course with the Nonresident Training Course Administration Branch at the Naval Education and Training Professional Development and Technology Center (NETPDTC). Following enrollment, there are two ways of having your assignments graded: (1) use the Internet to submit your assignments as you complete them, or (2) send all the assignments at one time by mail to NETPDTC.

**Grading on the Internet:** Advantages to Internet grading are:

- you may submit your answers as soon as you complete an assignment, and
- you get your results faster; usually by the next working day (approximately 24 hours).

In addition to receiving grade results for each assignment, you will receive course completion confirmation once you have completed all the

assignments. To submit your assignment answers via the Internet, go to:

<http://courses.cnet.navy.mil>

**Grading by Mail:** When you submit answer sheets by mail, send all of your assignments at one time. Do NOT submit individual answer sheets for grading. Mail all of your assignments in an envelope, which you either provide yourself or obtain from your nearest Educational Services Officer (ESO). Submit answer sheets to:

COMMANDING OFFICER  
NETPDTC N331  
6490 SAUFLEY FIELD ROAD  
PENSACOLA FL 32559-5000

**Answer Sheets:** All courses include one "scannable" answer sheet for each assignment. These answer sheets are preprinted with your SSN, name, assignment number, and course number. Explanations for completing the answer sheets are on the answer sheet.

**Do not use answer sheet reproductions:** Use only the original answer sheets that we provide—reproductions will not work with our scanning equipment and cannot be processed.

Follow the instructions for marking your answers on the answer sheet. Be sure that blocks 1, 2, and 3 are filled in correctly. This information is necessary for your course to be properly processed and for you to receive credit for your work.

## COMPLETION TIME

Courses must be completed within 12 months from the date of enrollment. This includes time required to resubmit failed assignments.

## **PASS/FAIL ASSIGNMENT PROCEDURES**

If your overall course score is 3.2 or higher, you will pass the course and will not be required to resubmit assignments. Once your assignments have been graded you will receive course completion confirmation.

If you receive less than a 3.2 on any assignment and your overall course score is below 3.2, you will be given the opportunity to resubmit failed assignments. **You may resubmit failed assignments only once.** Internet students will receive notification when they have failed an assignment—they may then resubmit failed assignments on the web site. Internet students may view and print results for failed assignments from the web site. Students who submit by mail will receive a failing result letter and a new answer sheet for resubmission of each failed assignment.

## **COMPLETION CONFIRMATION**

After successfully completing this course, you will receive a letter of completion.

## **ERRATA**

Errata are used to correct minor errors or delete obsolete information in a course. Errata may also be used to provide instructions to the student. If a course has an errata, it will be included as the first page(s) after the front cover. Errata for all courses can be accessed and viewed/downloaded at:

**<http://www.advancement.cnet.navy.mil>**

## **STUDENT FEEDBACK QUESTIONS**

We value your suggestions, questions, and criticisms on our courses. If you would like to communicate with us regarding this course, we encourage you, if possible, to use e-mail. If you write or fax, please use a copy of the Student Comment form that follows this page.

## **For subject matter questions:**

E-mail: n315.products@cnet.navy.mil  
Phone: Comm: (850) 452-1001, Ext. 1776  
DSN: 922-1001, Ext. 1776  
FAX: (850) 452-1370  
(Do not fax answer sheets.)  
Address: COMMANDING OFFICER  
NETPDTC N3442  
6490 SAUFLEY FIELD ROAD  
PENSACOLA FL 32509-5237

## **For enrollment, shipping, grading, or completion letter questions**

E-mail: fleetservices@cnet.navy.mil  
Phone: Toll Free: 877-264-8583  
Comm: (850) 452-1511/1181/1859  
DSN: 922-1511/1181/1859  
FAX: (850) 452-1370  
(Do not fax answer sheets.)  
Address: COMMANDING OFFICER  
NETPDTC (CODE N331)  
6490 SAUFLEY FIELD ROAD  
PENSACOLA FL 32559-5000

## **NAVAL RESERVE RETIREMENT CREDIT**

If you are a member of the Naval Reserve, you may earn retirement points for successfully completing this course, if authorized under current directives governing retirement of Naval Reserve personnel. For Naval Reserve retirement, this course is evaluated at 9 points. (Refer to *Administrative Procedures for Naval Reservists on Inactive Duty*, BUPERSINST 1001.39, for more information about retirement points.)

(THIS PAGE IS INTENTIONALLY LEFT BLANK.)



## Student Comments

**Course Title:** Aviation Electricity and Electronics—Maintenance Fundamentals

**NAVEDTRA:** 14318 **Date:** \_\_\_\_\_

**We need some information about you:**

Rate/Rank and Name: \_\_\_\_\_ SSN: \_\_\_\_\_ Command/Unit \_\_\_\_\_

Street Address: \_\_\_\_\_ City: \_\_\_\_\_ State/FPO: \_\_\_\_\_ Zip \_\_\_\_\_

**Your comments, suggestions, etc.:**

**Privacy Act Statement:** Under authority of Title 5, USC 301, information regarding your military status is requested in processing your comments and in preparing a reply. This information will not be divulged without written authorization to anyone other than those within DOD for official use in determining performance.

NETPDTC 1550/41 (Rev 4-00)



## CHAPTER 1

# MATHEMATICS - BASICS

Mathematics is a basic tool. Some use of mathematics is found in every rating in the Navy, from the simple arithmetic of counting for inventory purposes to the complicated equations encountered in computer and engineering work. Storekeepers need mathematical computation in their bookkeeping. Damage Controlmen need mathematics to compute stress, centers of gravity, and maximum permissible roll. Electronics principles are frequently stated by means of mathematical formulas. Navigation and engineering also use mathematics to a great extent. As maritime warfare becomes more and more complex, mathematics achieves ever-increasing importance as an essential tool.

Many of us have areas in our mathematics background that are hazy or troublesome. While it may seem unnecessary to read chapters on fundamental arithmetic, these basic concepts may be just the spot where your difficulties lie.

### FRACTIONS

**LEARNING OBJECTIVES:** Identify the parts and types of fractions. Solve mathematical problems that involve fractions.

The simplest type of number other than an integer (a positive or negative whole number) is a common fraction. A fraction is an expression that represents a part, or several equal parts, of a unit. The number line may be used to show the relationship between integers and fractions. Refer to figure 1-1. For example, the interval between 0 and 1 is marked off to form three equal spaces (thirds), then each space is one third of the total interval. If we move along the number line from 0 toward 1 we will have covered three thirds when we reach the 1, thus  $\frac{3}{3}$  is equal to a whole.

### PARTS OF A FRACTION

In writing a fraction, as in  $\frac{2}{3}$  (two thirds), the number after or below the bar is called the *denominator* and indicates the total number of equal parts into which the unit has been divided, the *divisor*. The number before or above the bar is called the *numerator*,

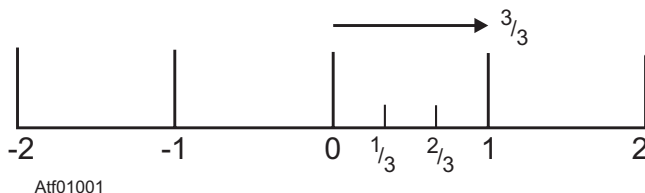

Figure 1-1.—Integers and fractions on the number line.

indicating how many of these equal parts are being considered, the *dividend*. Therefore, with the fraction  $\frac{2}{3}$  we are dealing with 2 of 3 equally divided parts of a whole.

### TYPES OF FRACTIONS

When using fractions to express the value of a unit mathematically, it normally is stated as a proper fraction, improper fraction, or a mixed number.

- A *proper fraction* is one in which the numerator is numerically smaller than the denominator, for example  $\frac{2}{3}$ ,  $\frac{3}{4}$ ,  $\frac{7}{8}$ , etc.
- An *improper fraction* has a numerator that is larger than its denominator, as in  $\frac{4}{3}$ ,  $\frac{7}{4}$ ,  $\frac{11}{8}$ , and so on.
- A *mixed number* is a whole number added to a proper fraction, and is usually written without showing the plus sign; that is,  $1 + \frac{1}{2}$  is the same as  $1\frac{1}{2}$ .

### IMPROPER FRACTIONS AND EQUIVALENT MIXED NUMBERS

Although the “improper” fraction is really “proper” mathematically, it is usually changed to a mixed number. Conversely, mixed numbers often are converted to improper fractions for computation.

## Converting an Improper Fraction to a Mixed Number

Since a fraction is an indication of division, the improper fraction  $\frac{8}{3}$  may be considered as the division of 8 by 3. This division is carried out as follows:

$$\begin{array}{r} 2 \text{ r } 2 = 2\frac{2}{3} \\ 3 \overline{)8} \\ \underline{6} \\ 2 \end{array}$$

Looked at another way: If 1 equals  $\frac{3}{3}$ , then 2 equals  $\frac{6}{3}$ .

$$\text{Thus, } 2\frac{2}{3} = 2 + \frac{2}{3} = \frac{6}{3} + \frac{2}{3} = \frac{8}{3}.$$

As seen, to change an improper fraction to a mixed number, divide the numerator by the denominator and write the fractional part of the quotient (the quantity resulting from the division) with the remainder as the numerator and the divisor as the denominator.

## Converting a Mixed Number to an Improper Fraction

In computation, mixed numbers can be difficult to work with, so it is often necessary to change a mixed number to an improper fraction.

Example: Change  $2\frac{1}{5}$  to an improper fraction.

Solution:

Write  $2\frac{1}{5}$  as a whole number plus a fraction,  
 $2 + \frac{1}{5}$ .

Change 2 to an equivalent fraction with a denominator of 5

$$\begin{array}{l} \frac{2}{1} = \frac{?}{5} \\ \frac{2(5)}{1(5)} = \frac{10}{5} \\ \text{Add: } \frac{10}{5} + \frac{1}{5} = \frac{11}{5} \\ \text{Thus: } 2\frac{1}{5} = \frac{11}{5} \end{array}$$

Example: Write  $5\frac{2}{9}$  as an improper fraction.

$$5\frac{2}{9} = 5 + \frac{2}{9}$$

$$\frac{5}{1} = \frac{?}{9}$$

$$\frac{5(9)}{1(9)} = \frac{45}{9}$$

$$\frac{45}{9} + \frac{2}{9} = \frac{47}{9}$$

$$5\frac{2}{9} = \frac{47}{9}$$

In each of the examples, notice that the multiplier is the number of the denominator of the fractional part of the original mixed number. Therefore, to change a mixed number to an improper fraction, multiply the whole number part by the denominator of the fractional part and add the numerator of the fractional part to this product. The result is the numerator of the improper fraction; its denominator is the same as the denominator of the fractional part of the original mixed number.

## REDUCING FRACTIONS TO LOWEST TERMS

In computation, fractions usually should be reduced to lowest possible terms. Changing a fraction to an equivalent fraction with the smallest terms, that is, with the smallest possible numerator and denominator, is called *reduction*. Thus,  $\frac{6}{30}$  reduced to lowest terms is

$\frac{1}{5}$ . Find the largest factor that is common to both the numerator and denominator and divide both of these terms by it. Dividing both terms of the preceding example by 6 reduces the fraction to lowest terms. If the greatest common factor cannot readily be found, any common factor may be removed and the process repeated until the fraction is in the lowest terms. Thus,  $\frac{18}{48}$  first could be divided by 2 and then by 3.

## ADDITION AND SUBTRACTION OF FRACTIONS AND MIXED NUMBERS

When performing addition and subtraction of fractions, the fractions must be *like fractions*, that is, fractions with the same denominator. We can add eighths to eighths, fourths to fourths, but not fourths to eighths. To add  $\frac{1}{5}$  to  $\frac{2}{5}$  we simply add the numerators and retain the denominator unchanged. The

denominator is fifths, so we add 1 fifth to 2 fifths to get 3 fifths, or

$$\frac{1}{5} + \frac{2}{5} = \frac{1+2}{5} = \frac{3}{5}$$

We have shown that like fractions are added by simply adding the numerators and keeping the denominator. Similarly, we can subtract like fractions by subtracting the numerators and keeping the denominator:

$$\frac{7}{8} - \frac{2}{8} = \frac{7-2}{8} = \frac{5}{8}$$

Before adding or subtracting fractions with different denominators, called *unlike fractions*, unlike fractions must be changed to like fractions by finding the lowest common denominator (LCD). The LCD is the least common multiple of the denominators. For example, with  $\frac{1}{2} + \frac{1}{3}$ , the LCD of the denominators 2 and 3 is 6. Therefore:

$$\frac{1}{2} + \frac{1}{3} = \frac{3}{6} + \frac{2}{6} = \frac{5}{6}$$

An example when adding 3 or more fractions:

$$\frac{1}{5} + \frac{3}{10} + \frac{1}{4}$$

The LCD is 20, therefore:

$$\begin{aligned} \frac{1}{5} + \frac{3}{10} + \frac{1}{4} &= \frac{4}{20} + \frac{6}{20} + \frac{5}{20} = \frac{15}{20} \\ \frac{15}{20} &= \frac{3}{4} \end{aligned}$$

Now let's look at an example of subtraction:

$$\frac{1}{3} - \frac{1}{4} = \frac{4}{12} - \frac{3}{12} = \frac{1}{12}$$

This rule of likeness also applies when adding or subtracting mixed numbers. Whole numbers are added to and subtracted from whole numbers and fractions to or from fractions. For example, to add  $4\frac{5}{8} + 2\frac{1}{2} + \frac{1}{4}$ :

$$\begin{aligned} 4\frac{5}{8} &= 4\frac{5}{8} \\ 2\frac{1}{2} &= 2\frac{4}{8} \\ \frac{1}{4} &= \frac{2}{8} \\ \hline 6\frac{11}{8} \end{aligned}$$

Since  $\frac{11}{8}$  equals  $1\frac{3}{8}$ , the final answer is found as follows:

$$\begin{aligned} 6\frac{11}{8} &= 6 + 1 + \frac{3}{8} \\ &= 7\frac{3}{8} \end{aligned}$$

The following example demonstrates a practical application of addition and subtraction involving fractions and mixed numbers.

Example: Find the length of dimension  $D$  of the coax cable shown in figure 1-2, where  $A = 1\frac{5}{32}$ ,  $B = \frac{7}{32}$ , and  $C = \frac{9}{16}$ .

$$\begin{array}{r} \text{Add } B \text{ and } C \\ \frac{7}{32} + \frac{9}{16} = \frac{7}{32} + \frac{18}{32} \\ \hline \frac{25}{32} \end{array}$$

$$\begin{array}{r} \text{Subtract } B + C \text{ from } A \\ 1\frac{5}{32} - \frac{25}{32} = \frac{37}{32} - \frac{25}{32} \\ \hline \frac{12}{32} \end{array}$$

Since  $\frac{12}{32}$  equals  $\frac{3}{8}$ , dimension  $D$  equals  $\frac{3}{8}$ .

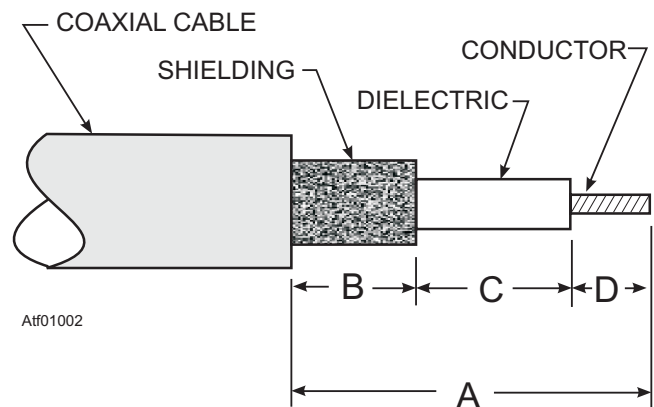

Figure 1-2.—Coax cable dimensions.

## MULTIPLICATION OF FRACTIONS AND MIXED NUMBERS

The fact that multiplication by a fraction does not increase the value of the product may confuse some people. How is it that  $\frac{1}{2} \times 4 = 2$ , a number less than 4?

Obviously, our idea of multiplication must be broadened. Consider the following products:

$$4(4) = 16$$

$$3(4) = 12$$

$$2(4) = 8$$

$$1(4) = 4$$

$$\frac{1}{2}(4) = 2$$

$$\frac{1}{4}(4) = 1$$

Notice that as the multiplier decreases, the product decreases, until, when the multiplier is a fraction, the product is less than 4 and continues to decrease as the fraction decreases. The fraction introduces the "part of" idea:  $\frac{1}{2}(4)$  means half of 4;  $\frac{1}{4}(4)$  means one-fourth of 4.

The definition of multiplication stated for whole numbers may be extended to include fractions. Since  $4(5)$  means that 5 is to be used 4 times as an addend, we can say that with fractions the numerator of the multiplier tells how many times the numerator of the multiplicand is to be used as an addend. Also, the denominator of the multiplier tells how many times the denominator of the multiplicand is to be used as an addend. For example, the fraction  $\frac{1}{12}$  is multiplied by the whole number 4 as follows:

$$\begin{aligned} 4 \times \frac{1}{12} &= \frac{4}{1} \times \frac{1}{12} \\ &= \frac{1+1+1+1}{12} \\ &= \frac{4}{12} = \frac{1}{3} \end{aligned}$$

This example shows that  $4 \times \frac{1}{12}$  is the same as  $\frac{4(1)}{12}$ .

Another way of thinking about the multiplication of  $\frac{1}{12}$  by 4 is as follows:

$$\begin{aligned} 4 \times \frac{1}{12} &= \frac{1}{12} + \frac{1}{12} + \frac{1}{12} + \frac{1}{12} \\ &= \frac{4}{12} = \frac{1}{3} \end{aligned}$$

As another example, the fraction  $\frac{2}{3}$  is multiplied by

$\frac{1}{2}$  as follows:

$$\begin{aligned} \frac{1}{2} \times \frac{2}{3} &= \frac{2}{6} \\ &= \frac{2}{6} = \frac{1}{3} \end{aligned}$$

As seen, to find the product of two or more fractions, multiply their numerators together for the numerator of the product, multiply their denominators for the denominator of the product, and reduce the answer to lowest terms.

When using this rule with whole numbers, write each whole number as a fraction with 1 as the denominator. When using this rule with mixed numbers, rewrite all mixed numbers as improper fractions before applying the rule. For example:

$$\begin{aligned} 2\frac{1}{3} \times \frac{1}{2} &= \frac{7}{3} \times \frac{1}{2} \\ &= \frac{7}{6} \\ &= 1\frac{1}{6} \end{aligned}$$

A second method of multiplying mixed numbers makes use of the distributive law. This law states that a multiplier applied to a two-part expression is distributed over both parts. For example, to multiply  $6\frac{1}{3}$

by 4 we may rewrite  $6\frac{1}{3}$  as  $6 + \frac{1}{3}$ . Then the problem can

be written as  $4\left(6 + \frac{1}{3}\right)$  as follows:

$$\begin{aligned} 4\left(6 + \frac{1}{3}\right) &= 24 + \frac{4}{3} \\ &= 25 + \frac{1}{3} \\ &= 25\frac{1}{3} \end{aligned}$$

Computation can be considerably reduced by dividing out (canceling) factors common to both the

numerator and the denominator. We recognize a fraction as an indicated division. Thinking of  $\frac{6}{9}$  as an

indicated division, we can simplify division by showing both dividend and divisor as the indicated products of their factors and then dividing like factors, or canceling. Thus,

$$\frac{6}{9} = \frac{2 \times 3}{3 \times 3}$$

Dividing (or canceling) the factor 3 in the numerator by 3 in the denominator gives the following simplified result:

$$\frac{1}{3} \times \frac{2 \times \cancel{3}}{\cancel{3} \times 3} = \frac{2}{3}$$

This method is best when done before any other computation. For example,

$$\frac{1}{3} \times \frac{3}{2} \times \frac{2}{5}$$

The product in factor form is

$$\frac{1 \times 3 \times 2}{3 \times 2 \times 5} = \frac{6}{30}$$

Rather than doing the multiplying and then reducing  $\frac{6}{30}$ , it is simpler to cancel like factors first, as follows:

$$\frac{1}{3} \times \frac{\cancel{3}}{2} \times \frac{2}{\cancel{2} \times 5} = \frac{1}{5}$$

Likewise,

$$\frac{2}{3} \times \frac{\cancel{6}}{4} \times \frac{5}{\cancel{9}} = \frac{5}{9}$$

Here we mentally factor 6 to the form  $3 \times 2$ , and 4 to the form  $2 \times 2$ . Cancellation is a valuable tool in shortening operations with fractions. The rule may be applied to mixed numbers by changing them to improper fractions.

## DIVISION OF FRACTIONS AND MIXED NUMBERS

There are two methods commonly used for division with fractions, the common denominator method and the reciprocal method.

The common denominator method is an adaptation of the method of like fractions. The rule is as follows: Change the dividend and divisor to like fractions and divide the numerator of the dividend by the numerator of the divisor. This method can be demonstrated with whole numbers, first changing them to fractions with 1 as the denominator. For example,  $12 \div 4$  can be written as follows:

$$12 \div 4 = \frac{12}{1} \div \frac{4}{1} \\ = \frac{12 \div 4}{1 \div 1} = \frac{3}{1} = 3$$

If the dividend and divisor are both fractions, as in  $\frac{1}{3}$  divided by  $\frac{1}{4}$ , we proceed as follows:

$$\frac{1}{3} \div \frac{1}{4} = \frac{4}{12} \div \frac{3}{12} \\ = \frac{4 \div 3}{12 \div 12} \\ = \frac{4 \div 3}{1} \\ = 4 \div 3 = 1\frac{1}{3}$$

In the reciprocal method, the word *reciprocal* is used to describe a specific relationship between two numbers. We say that two numbers are reciprocals of each other if their product is one. In the example  $4 \times \frac{1}{4} = 1$ , the fractions  $\frac{4}{1}$  and  $\frac{1}{4}$  are reciprocals.

What is the reciprocal of  $\frac{3}{7}$ ? It must be a number which, when multiplied by  $\frac{3}{7}$ , produces the product 1.

Therefore:

$$\frac{3}{7} \times ? = 1 \\ \frac{1}{7} \times \frac{7}{3} = 1 \\ 1 \quad 1$$

We see that  $\frac{7}{3}$  is the only number that could fulfill the requirement. Notice that the numerator and the denominator  $\frac{3}{7}$  were simply interchanged to get the reciprocal. If we know a number, we can always find its reciprocal by dividing 1 by the number. Notice the principle in the following examples:

What is the reciprocal of 7?

$$1 \div 7 = \frac{1}{7}$$

Check:

$$\frac{7}{1} \times \frac{1}{7} = 1$$

Notice that the cancellation process in this example does not show the 1's which result when dividing a number into itself. For example, when 7 cancels 7, the quotient 1 could be shown beside each of the 7's. However, since 1 as a factor has the same effect whether it is written or simply understood, the 1's need not be written.

What is the reciprocal of  $3\frac{1}{8}$ ?

$$\begin{aligned} 1 \div 3\frac{1}{8} &= \frac{8}{8} \div \frac{25}{8} \\ &= 8 \div 25 \\ &= \frac{8}{25} \end{aligned}$$

Check:

$$\frac{25}{8} \times \frac{8}{25} = 1$$

The need for dividing fractions may arise in electronics when it is necessary to find the total resistance of several resistors in parallel as shown in figure 1-3. The rule is the total resistance of a circuit is 1 divided by the sum of the reciprocals of the separate resistances. Written as a formula, this produces the following expression:

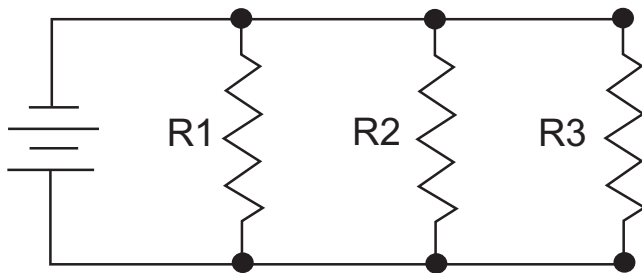

Figure 1-3.—Parallel resistance calculation.

$$R_t = \frac{1}{\frac{1}{R_1} + \frac{1}{R_2} + \frac{1}{R_3}}$$

Example: Find the total resistance ( $R_t$ ) of the parallel circuit in figure 1-3. Substituting the values 3, 4, and 6 for the letters  $R_1$ ,  $R_2$ , and  $R_3$ , we have the following:

$$R_t = \frac{1}{\frac{1}{3} + \frac{1}{4} + \frac{1}{6}}$$

The LCD of the fractions  $\frac{1}{3}$ ,  $\frac{1}{4}$ , and  $\frac{1}{6}$ , is 12. Thus:

$$\begin{aligned} R_t &= \frac{1}{\frac{4}{12} + \frac{3}{12} + \frac{2}{12}} \\ &= \frac{1}{\frac{9}{12}} \\ &= \frac{12}{9} = \frac{4}{3} \\ &= 1\frac{1}{3} \text{ ohms (measure of resistance).} \end{aligned}$$

Q1-1. What is the bottom number of a fraction called?

1. Numerator
2. Dividend
3. Denominator
4. Integer

Q1-2. An improper fraction has a denominator that is larger than its numerator.

1. True
2. False

Q1-3. What is  $\frac{12}{5}$  expressed as a mixed number?

1.  $1\frac{2}{5}$
2.  $1\frac{1}{5}$
3.  $2\frac{1}{5}$
4.  $2\frac{2}{5}$



Q1-4. What is  $3\frac{7}{16}$  expressed as an improper fraction?

1.  $\frac{14}{16}$
2.  $\frac{21}{16}$
3.  $\frac{32}{16}$
4.  $\frac{55}{16}$

Q1-5. What is  $\frac{5}{20}$  reduced to lowest terms?

1.  $\frac{1}{4}$
2.  $\frac{1}{3}$
3.  $\frac{1}{2}$
4.  $\frac{1}{5}$

Q1-6. What is the sum of  $\frac{9}{16} + \frac{3}{4} + \frac{7}{8}$ ?

1.  $\frac{19}{28}$
2.  $1\frac{1}{3}$
3.  $2\frac{3}{16}$
4.  $2\frac{7}{16}$

Q1-7. Find the length of dimension B of the coax cable shown in figure 1-2, where  $A = 1\frac{7}{32}$ ,

$$C = \frac{5}{16}, \text{ and } D = \frac{3}{8}.$$

1.  $\frac{3}{8}$
2.  $\frac{17}{32}$

3.  $\frac{22}{32}$

4.  $\frac{39}{32}$

Q1-8. What is the product of  $\frac{1}{2} \times \frac{1}{3} \times \frac{2}{5}$ ?

1.  $\frac{1}{30}$

2.  $\frac{1}{15}$

3.  $\frac{4}{30}$

4.  $1\frac{1}{30}$

Q1-9. What is the reciprocal of  $2\frac{1}{2}$ ?

1.  $\frac{2}{5}$

2. 1

3.  $1\frac{1}{4}$

4. 5

Q1-10. What is the approximate resistance ( $R_T$ ) of the circuit in figure 1-3 when  $R_1 = 2$ ,  $R_2 = 6$ , and  $R_3 = 8$ ?

1.  $\frac{7}{10}$  ohms

2.  $1\frac{3}{4}$  ohms

3.  $1\frac{1}{2}$  ohms

4.  $1\frac{1}{4}$  ohms

## SIGNED NUMBERS

**LEARNING OBJECTIVES:** Define the terms associated with signed numbers. Perform mathematical operations that involve signed numbers.

*Signed numbers* are numbers that show either a plus or minus sign preceding them. The numbers with which we have worked so far are not sufficient for every

situation that may arise. For example, a negative number results in the operation of subtraction when the subtrahend (number to be subtracted) is larger than the minuend (number from which to subtract).

### TERMS ASSOCIATED WITH SIGNED NUMBERS

*Positive numbers* are numbers relating to or designating a quantity greater than zero. Positive numbers are designated by the sign +. An unsigned number is understood to be positive and is treated as though there were a plus sign preceding it. To emphasize the fact that a number is positive, place a plus sign in front of the number, as in +5, which is read “plus five.” Therefore, either +5 or 5 indicates that the number 5 is positive.

*Negative numbers* are numbers relating to or designating a quantity less than zero. Negative numbers are designated by the sign -. The number -8 is read “minus eight.” You might see an example with temperature changes. If the temperature was 12 degrees yesterday and dropped 20 degrees today, the reading today would be  $12 - 20$ , or -8 degrees. If a number is negative, a minus sign must appear in front of it, as in -9.

In dealing with signed numbers, it should be emphasized that the plus and minus signs have two separate and distinct functions. They may indicate whether a number is positive or negative, or they may indicate the operation of addition or subtraction.

When operating entirely with positive numbers, plus or minus signs indicate only addition or subtraction. However, when negative numbers are used, it is important to distinguish between a sign of operation and the sign of a number.

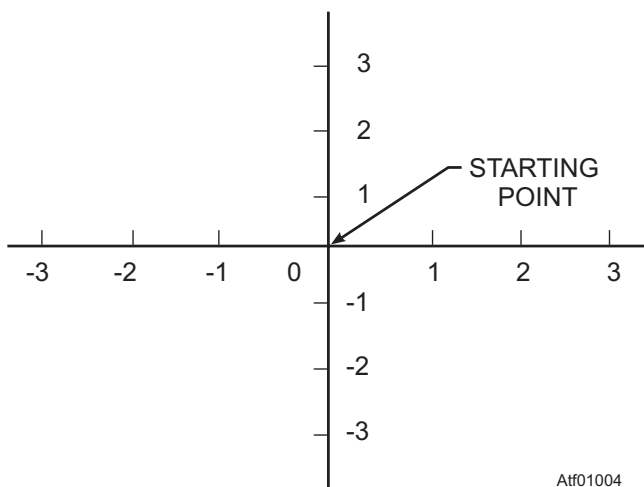

Figure 1-4.—Rectangular coordinate system.

The *absolute value* of a number is its numerical value when the sign is dropped. The absolute value of either +5 or -5 is 5. Thus, two numbers that differ only in sign have the same absolute value. The symbol for absolute value consists of two vertical bars placed one on each side of the number, as in  $|-5| = 5$ . Consider also the following:

$$|14 - 20| = 6$$

$$|+7| = |-7| = 7$$

The expression  $|-7|$  is read “absolute value of minus seven.”

When positive and negative numbers are used to indicate direction of measurement, we are concerned only with absolute value if we wish to know only the distance covered. For example, in figure 1-4, if an object moves to the left from the starting point to the point indicated by -2, the actual distance covered is 2 units. We are concerned only with the fact that  $|-2| = 2$ , if our only interest is in the distance and not the direction. The same would be true whether we moved left or right on the horizontal plane or up or down on the vertical plane.

### MATHEMATICAL OPERATIONS OF SIGNED NUMBERS

Sometimes it is important to know the relative greatness (magnitude) of positive and negative numbers. To determine whether a particular number is greater or less than another number, think of all the numbers both positive and negative as being arranged along a horizontal line. (See fig. 1-5.)

Positive numbers extend from zero toward the right, and negative numbers extend from zero toward the left. Positive and negative numbers progress from smaller to larger numbers as we move from left to right along the line. Any number that lies to the right of a given number is greater than the given number. A number that lies to the left of a given number is less than the given number. This arrangement shows that any negative number is smaller than any positive number.

The symbol for *greater than* is >. The symbol for *less than* is <. Remember that the symbol used always opens toward the larger number. For example, “7 is

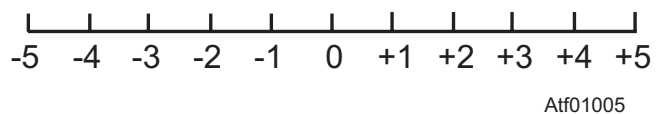

Atf01005

Figure 1-5.—Number line showing both positive and negative numbers.

greater than 4” can be written  $7 > 4$  and “-5 is less than -1”, can be written  $-5 < -1$ .

### Addition of Signed Numbers

The number line can be used to demonstrate addition of signed numbers. Two cases must be considered; namely, adding numbers with like signs and adding numbers with unlike signs.

**ADDING LIKE SIGNS.**—As an example of addition with like signs, suppose that we use the number line (fig. 1-5) to add  $2 + 3$ . Since these are signed numbers, we indicate this addition as  $(+2) + (+3)$ . This emphasizes that, among the three + signs shown, two are number signs and one is a sign of operation. Find 2 on the number line. To add 3 to it, go three units more in a positive direction and get 5. To add two negative numbers on the number line, such as  $-2$  and  $-3$ , find  $-2$  on the number line and then go three units more in the negative direction to get  $-5$ .

The law for this may be stated: To add numbers with like signs, add the absolute values and prefix the common sign.

**ADDING UNLIKE SIGNS.**—To add a positive and a negative number, such as  $(-4) + (+5)$ , find  $+5$  on the number line and go four units in a negative direction to get  $+1$ . Notice that this addition could be performed in the other direction. That is, we could start at  $-4$  and move 5 units in the positive direction to get  $+1$ .

The law for this may be stated: To add numbers with unlike signs, find the difference between their absolute values and prefix the sign of the numerically greater number.

The following examples show the addition of the numbers 3 and 5 with the four possible combinations of signs:

$$\begin{array}{r} 3 \\ +5 \\ \hline 8 \end{array} \quad \begin{array}{r} -3 \\ + -5 \\ \hline -8 \end{array} \quad \begin{array}{r} 3 \\ + -5 \\ \hline -2 \end{array} \quad \begin{array}{r} -3 \\ + 5 \\ \hline 2 \end{array}$$

In the first example, 3 and 5 have like signs and the common sign is understood to be positive. The sum of the absolute values is 8, and no sign is prefixed to this sum, as the sign of the 8 is understood to be positive.

In the second example, the 3 and 5 again have like signs, but their common sign is negative. The sum of the absolute values is 8, and this time the common sign is prefixed to the sum,  $-8$ .

In the third example, the 3 and 5 have unlike signs. The difference between their absolute values is 2, and the sign of the larger addend is negative. Therefore, the answer is  $-2$ .

In the fourth example, the 3 and 5 again have unlike signs. The difference of the absolute values is still 2, but this time the sign of the larger addend is positive. Therefore, the sign prefixed to the 2 is positive (understood).

These four examples could be written in a different form, emphasizing the distinction between the sign of a number and an operational sign, as follows:

$$\begin{aligned} (+3) + (+5) &= +8 \\ (-3) + (-5) &= -8 \\ (+3) + (-5) &= -2 \\ (-3) + (+5) &= +2 \end{aligned}$$

### Subtraction of Signed Numbers

Subtraction is the inverse of addition. When subtraction is performed, we *take away* the subtrahend. This means that whatever the value of the subtrahend, its effect is to be reversed when subtraction is indicated. In addition, the sum of 5 and  $-2$  is 3. In subtraction, however, to take away the effect of the  $-2$ , the quantity  $+2$  must be added. Thus, the difference between  $+5$  and  $-2$  is  $+7$ .

Keeping this idea in mind, let’s look at the various combinations of subtraction involving signed numbers. First, consider the four possibilities where the minuend is numerically greater than the subtrahend, as in the following examples:

$$\begin{array}{r} 8 \\ -5 \\ \hline 3 \end{array} \quad \begin{array}{r} 8 \\ - -5 \\ \hline 13 \end{array} \quad \begin{array}{r} -8 \\ -5 \\ \hline -13 \end{array} \quad \begin{array}{r} -8 \\ - -5 \\ \hline -3 \end{array}$$

We may show how each of these results is obtained by use of the number line, shown in figure 1-5.

In the first example, we find  $+8$  on the number line, then subtract 5 by making a movement that reverses its sign. Thus, we move to the left 5 units. The result (difference) is  $+3$ .

In the second example, we find  $+8$  on the number line, then subtract  $-5$  by making a movement that will reverse its sign. Thus, we move to the right 5 units. The result in this case is  $+13$ .

In the third example, we find  $-8$  on the number line, then subtract 5 by making a movement that reverses its

sign. Thus, we move to the left 5 units. The result is  $-13$ .

In the fourth example, we find  $-8$  on the number line, then reverse the sign of  $-5$  by moving 5 units to the right. The result is  $-3$ .

Next, let us consider the four possibilities that arise when the subtrahend is numerically greater than the minuend, as in the following examples:

$$\begin{array}{r} 5 \\ -8 \\ -3 \end{array} \quad \begin{array}{r} 5 \\ --8 \\ 13 \end{array} \quad \begin{array}{r} -5 \\ -8 \\ -13 \end{array} \quad \begin{array}{r} -5 \\ --8 \\ 3 \end{array}$$

In the first example, we find  $+5$  on the number line, then subtract 8 by making a movement that reverses its sign. Thus, we move to the left 8 units. The result is  $-3$ .

In the second example, we find  $+5$  on the number line, then subtract  $-8$  by making a movement to the right that reverses its sign. The result is 13.

In the third example, we find  $-5$  on the number line, then reverse the sign of 8 by a movement to the left. The result is  $-13$ .

In the fourth example, we find  $-5$  on the number line, then reverse the sign of  $-8$  by a movement to the right. The result is 3.

The law for subtraction of signed numbers may be stated: In any subtraction problem, mentally change the sign of the subtrahend and proceed as in addition.

### Multiplication of Signed Numbers

Remember that multiplication of whole numbers may be thought of as shortened addition. Two types of multiplication problems must be examined: numbers with unlike signs and numbers with like signs.

**MULTIPLY UNLIKE SIGNS.**—Consider the example  $3(-4)$ , in which the multiplicand is negative. This means we are to add  $-4$  three times; that is,  $3(-4)$  is equal to  $(-4) + (-4) + (-4)$ , which is equal to  $-12$ . For example, if we have three 4-dollar debts, we owe 12 dollars in all.

When the multiplier is negative, as in  $-3(7)$ , we are to take away 7 three times. Thus,  $-3(7)$  is equal to  $-(7) - (7) - (7)$ , which is equal to  $-21$ . For example, if 7 shells were expended in one firing, 7 the next, and 7 the next, there would be a loss of 21 shells in all. Thus, the rule is: The product of two numbers with unlike signs is negative.

The law of signs for unlike signs may be stated: Minus times plus is minus; plus times minus is minus. Thus a problem such as  $3(-4)$  can be reduced to the following two steps:

1. Multiply the signs and write down the sign of the answer before working with the numbers themselves.
2. Multiply the numbers as if they were unsigned numbers.

Using the suggested procedure, the sign of the answer for  $3(-4)$  is minus. The product of 3 and 4 is 12, and the final answer is  $-12$ . When there are more than two numbers to be multiplied, the signs are taken in pairs until the final sign is determined.

**MULTIPLY LIKE SIGNS.**—When both factors are positive, as in  $4(5)$ , the sign of the product is positive. We are to add  $+5$  four times, as follows:

$$4(5) = 5 + 5 + 5 + 5 = 20$$

When both factors are negative, as in  $-4(-5)$ , the sign of the product is positive. We are to take away  $-5$  four times.

$$\begin{aligned} -4(-5) &= -(-5)(-5)(-5)(-5) \\ &= +5 + 5 + 5 + 5 \\ &= 20 \end{aligned}$$

Remember that taking away a negative 5 is the same as adding a positive 5. For example, suppose someone owes a person 20 dollars and pays them back (or diminishes the debt) 5 dollars at a time. He takes away a debt of 20 dollars by giving him four positive 5-dollar bills, or a total of 20 positive dollars in all.

The rule for this is: The product of two numbers with like signs is positive.

Knowing that the product of two positive numbers or two negative numbers is positive, we can conclude that the product of any even number of negative numbers is positive. Similarly, the product of any odd number of negative numbers is negative.

The laws of signs may be combined as follows: Minus times plus is minus; plus times minus is minus; minus times minus is plus; plus times plus is plus. Use of this combined rule may be illustrated as follows:

$$4(-2) \cdot (-5) \cdot (6) \cdot (-3) = -720$$

Taking the signs in pairs, the understood plus on the 4 times the minus on the 2 produces a minus. This minus times the minus on the 5 produces a plus. This plus times the understood plus on the 6 produces a plus. This

plus times the minus on the 3 produces a minus, so we know that the final answer is negative. The product of the numbers, disregarding their signs, is 720; therefore, the final answer is  $-720$ .

### Division of Signed Numbers

Because division is the inverse of multiplication, we can quickly develop the rules for division of signed numbers by comparison with the corresponding multiplication rules, as in the following examples:

Division involving two numbers with unlike signs is related to multiplication with unlike signs, as follows:

$$3(-4) = -12$$

Therefore,

$$\frac{-12}{3} = -4$$

Thus, the rule for division with unlike signs is: The quotient of two numbers with unlike signs is negative.

Division involving two numbers with like signs is related to multiplication with like signs, as follows:

$$\begin{aligned} 3(-4) &= -12 \\ \frac{3(-4)}{-4} &= \frac{-12}{-4} \\ \frac{-12}{-4} &= 3 \\ 3 &= 3 \end{aligned}$$

Thus, the rule for division with like signs is: The quotient of two numbers with like signs is positive.

The following examples show the application of the rules for dividing signed numbers.

$$\begin{aligned} \frac{12}{3} = 4 \quad \frac{-12}{3} = -4 \\ \frac{-12}{-3} = 4 \quad \frac{12}{-3} = -4 \end{aligned}$$

### Special Cases Involving Signed Numbers

There are two special cases in which the laws of signs may be used to advantage, simplifying subtraction and changing the signs of the numerator and denominator when division is indicated in fractions.

**SUBTRACTION.**—The rules for subtraction may be simplified by use of the laws of signs if each expression to be subtracted is considered as being multiplied by a negative sign. For example,  $4 - (-5)$  is the same as  $4 + 5$ , since minus times minus is plus. This result also establishes a basis for the rule governing

removal of parentheses. The parentheses rule is: Parentheses preceded by a minus sign may be removed if the signs of all terms within the parentheses are changed. For example:  $12 - (3 - 2 + 4) = 12 - 3 + 2 - 4$ . Look at the negative sign preceding the parentheses as a multiplier for the whole parenthetical expression.

### DIVISION IN FRACTIONAL FORM.—

Writing the dividend as the numerator and the divisor as the denominator of a fraction often indicates division. In algebra, every fraction is considered to have three signs. The numerator has a sign, the denominator has a sign, and the fraction itself, taken as a whole, has a sign. Positive signs may not be shown. For example, in the following fraction, the sign of the numerator and the sign of the denominator are both positive (understood) and the sign of the fraction itself is negative.

$$-\frac{4}{5}$$

Fractions with more than one negative sign are always reducible to a simpler form with at most one negative sign. For example, the sign of the numerator and the sign of the denominator may both be negative. We note that minus divided by minus gives the same result as plus divided by plus. Therefore, we may change to the less complicated form having plus signs (understood) for both numerator and denominator, as follows:

$$\frac{-15}{-5} = \frac{+15}{+5} = \frac{15}{5}$$

Since  $-15$  divided by  $-5$  is 3, and  $15$  divided by  $5$  also is 3, we conclude that the change of sign does not alter the final answer. The same reasoning may be applied in the following example, in which the sign of the fraction itself is negative:

$$-\frac{-15}{-5} = -\frac{+15}{+5} = -\frac{15}{5}$$

When the fraction itself has a negative sign, as in this example, the fraction may be enclosed in parentheses temporarily, for the purpose of working with the numerator and denominator only. Then the sign of the fraction is applied separately to the result, as follows:

$$-\frac{-15}{-5} = -\left(\frac{-15}{-5}\right) = -(+3) = -3$$

If a fraction has a negative sign in one of the three sign positions, this sign may be moved to another position. Such an adjustment is an advantage in some types of complicated expressions involving fractions. Examples of this type of sign change follow:

$$-\frac{15}{5} = \frac{-15}{5} = \frac{15}{-5}$$

In the first expression of the foregoing example, the sign of the numerator is positive (understood) and the sign of the fraction is negative. Changing both of these signs, we obtain the second expression. To obtain the third expression from the second, we change the sign of the numerator and the sign of the denominator. Observe that the sign changes in each case involve a pair of signs. The law of signs for fractions states: Any two of the three signs of a fraction may be changed without altering the value of the fraction.

*Q1-11. Which of the following symbols indicates an absolute value of 6?*

1.  $< 6$
2.  $> 6$
3.  $\pm 6$
4.  $|6|$

*Q1-12. Which of the following indicates 9 is greater than 5?*

1.  $9 > 5$
2.  $9 < 5$
3.  $9 \pm 5$
4.  $9 \Delta 5$

*Q1-13. What is the sum of  $(-3) + (-7)$ ?*

1.  $+4$
2.  $-4$
3.  $+10$
4.  $-10$

*Q1-14. What is the sum of  $(-5) + (+7)$ ?*

1.  $+12$
2.  $-12$
3.  $+2$
4.  $-2$

*Q1-15. What is the difference of  $-6 - (-8)$ ?*

1.  $-2$
2.  $+2$
3.  $-14$
4.  $+14$

*Q1-16. What is the product of  $-7(3)(2)$ ?*

1.  $+42$
2.  $-42$
3.  $+21$
4.  $-21$

*Q1-17. What is the product of  $-4(-5)$ ?*

1.  $-16$
2.  $+16$
3.  $-20$
4.  $+20$

*Q1-18. What is the quotient of  $15 \div (-5)$ ?*

1.  $-3$
2.  $+3$
3.  $-45$
4.  $+45$

*Q1-19. Parentheses preceded by a minus sign may be removed if the signs of all terms within the parentheses are changed.*

1. True
2. False

*Q1-20.  $-\frac{-15}{-5}$  is equal to which of the following?*

1.  $\frac{-15}{-5}$
2.  $\frac{15}{5}$
3.  $-\frac{15}{5}$
4.  $-\frac{-15}{5}$

## FUNDAMENTALS OF ALGEBRA

**LEARNING OBJECTIVES:** Define the terms, definitions, and laws associated with algebra. Describe the terms and definitions associated with exponents and radicals. Perform mathematical operations that involve exponents and radicals. Perform algebraic operations that involve monomials and polynomials.

The numbers and operating rules of arithmetic form a part of a very important branch of mathematics called *algebra*.

Algebra extends the concepts of arithmetic so that it is possible to generalize the rules for operating with numbers and use these rules in manipulating symbols other than numbers. It does not involve an abrupt change into a new field, but rather provides a smooth transition into many branches of mathematics with knowledge gained in basic arithmetic.

The idea of expressing quantities in a general way, rather than in the specific terms of arithmetic, is common. A typical example is the formula for the perimeter of a rectangle,  $P = 2L + 2W$ , in which  $P$  represents perimeter,  $L$  represents length, and  $W$  represents width. Note that  $2L = 2(L)$  and  $2W = 2(W)$ . If the  $L$  and the  $W$  were numbers, parentheses or some other multiplication sign would be necessary, but the meaning of a term such as  $2L$  is clear without them.

All formulas are algebraic expressions, although they are not always identified as such. The letters used in algebraic expressions are often referred to as *literal numbers*.

## ALGEBRAIC LAWS AND RULES OF OPERATION

Another typical use of literal numbers is in the statement of mathematical laws of operation. For example, the commutative, associative, and distributive laws, with respect to arithmetic, may be restated in general terms by the use of algebraic symbols.

### Commutative Laws

The commutative laws refer to situations in which the factors and terms of an expression are rearranged in a different order.

The algebraic form of the commutative law for addition is as follows:

$$a + b = b + a$$

From this law, it follows that

$$a + (b + c) = a + (c + b) = (c + b) + a$$

This law states that the sum of two or more addends is the same regardless of the order in which the addends are arranged.

In the algebraic example,  $a$ ,  $b$ , and  $c$  represent any numbers we choose, thus giving a broad inclusive example of the rule. Note that once a value is selected

for a literal number, that value remains the same wherever the letter appears in that particular example or problem. Thus, if we give “ $a$ ” the value of 12, the value of “ $a$ ” is 12 wherever it appears.

The algebraic form of the commutative law for multiplication is as follows:

$$ab = ba$$

This law states that the product of two or more factors is the same regardless of the order in which the factors are arranged.

### Associative Laws

The associative laws of addition and multiplication refer to the grouping (association) of terms and factors in a mathematical expression.

The algebraic form of the associative law for addition is as follows:

$$a + b + c = (a + b) + c = a + (b + c)$$

This law states that the sum of three or more addends is the same regardless of the manner in which the addends are grouped.

The algebraic form of the associative law for multiplication is as follows:

$$a \cdot b \cdot c = (a \cdot b) \cdot c = a \cdot (b \cdot c)$$

This law states that the product of three or more factors is the same regardless of the manner in which the factors are grouped.

### Distributive Law

The distributive law refers to the distribution of factors among the terms of an additive expression. The algebraic form of this law is as follows:

$$a(b + c) = ab + ac$$

From this law, it follows that: If the sum of two or more quantities is multiplied by a third quantity, the product is found by applying the multiplier to each of the original quantities separately and summing the resulting expressions.

### Algebraic Sums

Since a literal number may represent either a positive or a negative quantity, a sum of several literal numbers is always understood to be an *algebraic sum*. That is, the sum results when the algebraic signs of all the addends are taken into consideration.

The following problems illustrate the procedure for finding an algebraic sum:

Let  $a = 3$ ,  $b = -2$ , and  $c = 4$ .

$$\begin{aligned} \text{Then } a + b + c &= (3) + (-2) + (4) \\ &= 5 \end{aligned}$$

$$\begin{aligned} \text{Also, } a - b - c &= a + (-b) + (-c) \\ &= 3 + (+2) + (-4) \\ &= 1 \end{aligned}$$

The second problem shows that every expression containing two or more terms to be combined by addition and subtraction may be rewritten as an algebraic sum, all negative signs being considered as belonging to specific terms and all operational signs being positive.

Note that the laws of signs for algebra are the same as those for arithmetic.

### Algebraic Expressions

An algebraic expression is made up of the signs and symbols of algebra, for example Arabic numerals, literal numbers, and the signs of operation. An expression represents one number or one quantity. Thus, just as the sum of 4 and 2 is one quantity, 6, the sum of  $c$  and  $d$  is one quantity,  $c + d$ . Likewise,  $\frac{a}{b}$ ,  $\sqrt{b}$ ,  $ab$ ,  $a - b$ , and so forth, are algebraic expressions, each of which represents one quantity or number.

Longer expressions may be formed by combinations of the various signs of operation and the other algebraic symbols. No matter how complex such expressions are, they still represent one number. Thus, the algebraic expression  $\frac{-a + \sqrt{2a + b}}{6} - c$  is one number.

The arithmetic value of any algebraic expression depends on the values assigned to the literal numbers. For example, in the expression  $2x^2 - 3ay$ , if  $x = -3$ ,  $a = 5$ , and  $y = 1$ , then we have the following:

$$\begin{aligned} 2x^2 - 3ay &= 2(-3)^2 - 3(5)(1) \\ &= 2(9) - 15 = 18 - 15 = 3 \end{aligned}$$

Notice that the exponent in an expression such as  $2x^2$  applies only to the  $x$ . To indicate the square of  $2x$ , rather than 2 times the square of  $x$ , use parentheses to make the expression  $(2x)^2$ .

Evaluate  $c + (ay^2 \div b) - 4a^2$ , when  $a = 4$ ,  $b = 2$ ,  $c = 3$ ,  $x = 7$  and  $y = 5$ .

Substitute the numerical values for the literal numbers in the expression.

$$3 + [4(5^2) \div 2] - 4(4^2) = ?$$

Perform the multiplication

$$3 + [4(25) \div 2] - 4(16) = ?$$

Perform the division

$$3 + (100 \div 2) - 64 = ?$$

Perform the addition

$$3 + 50 - 64 = ?$$

Perform the subtraction

$$53 - 64 = -11$$

**NOTE:** In any mathematical problem with multiple signs of operation, the order of operation is multiply, divide, add, and subtract.

**TERMS AND COEFFICIENTS.**—The *terms* of an algebraic expression are the parts of the expression that are connected by plus and minus signs. In the expression  $3abx + cy - k$ , for example,  $3abx$ ,  $cy$ , and  $k$  are the terms of the expression.

An expression containing only one term, such as  $3ab$ , is called a *monomial* (“mono” means one). A *binomial* contains two terms; for example,  $2r + by$ . A *trinomial* consists of three terms. Any expression containing two or more terms may also be called by the general name *polynomial* (“poly” means many). Usually, special names are not given to polynomials of more than three terms. The expression  $x^3 - 3x^2 + 7x + 1$  is a polynomial of four terms. The trinomial  $x^2 + 2x + 1$  is an example of a polynomial which has a special name.

In general, a coefficient of a term is any factor or group of factors of a term by which the remainder of the term is to be multiplied. In the term  $2axy$ ,  $2ax$  is the coefficient of  $y$ ,  $2a$  is the coefficient of  $xy$ , and 2 is the coefficient of  $axy$ . The word *coefficient* is usually used in reference to that factor which is expressed in Arabic numerals. This factor is sometimes called the *numerical coefficient*. The numerical coefficient is customarily written as the first factor of the term. In  $4x$ , 4 is the numerical coefficient, or simply the coefficient, of  $x$ . Likewise, in  $24xy^2$ , 24 is the coefficient of  $xy^2$ , and in  $16(a + b)$ , 16 is the coefficient of  $(a + b)$ . When no



numerical coefficient is written, it is understood to be 1, as in the term  $xy$ , where the coefficient is 1.

**COMBINING TERMS.**—When arithmetic numbers are connected by plus and minus signs, they can always be combined into one number. Thus,

$$5 - 7\frac{1}{2} + 8 = 5\frac{1}{2}$$

Here, three numbers are added algebraically to give one number. The terms have been combined into one term. Terms containing literal numbers can be combined only if their literal parts are the same. Terms containing literal factors in which the same letters are raised to the same power are called *like terms*. For example,  $3y$  and  $2y$  are like terms since the literal parts are the same. Like terms are added by adding the coefficients of the like parts. Thus,  $3y + 2y = 5y$  just as  $3 \text{ bolts} + 2 \text{ bolts} = 5 \text{ bolts}$ . Also  $3a^2b$  and  $a^2b$  are like;  $3a^2b + a^2b = 4a^2b$  and  $3a^2b - a^2b = 2a^2b$ . The numbers  $ay$  and  $by$  are like terms with respect to  $y$ . Their sum could be indicated in two ways:  $ay + by$  or  $(a + b)y$ . The latter may be explained by comparing the terms to denominate numbers. For instance,  $a \text{ bolts} + b \text{ bolts} = (a + b) \text{ bolts}$ .

Like terms are added or subtracted by adding or subtracting the numerical coefficients and placing the result in front of the literal factor, as in the following examples:

$$7x^2 - 5x^2 = (7 - 5)x^2 = 2x^2$$

$$5b^2x - 3ay^2 - 8b^2x + 10ay^2 = -3b^2x + 7ay^2$$

Dissimilar or unlike terms in an algebraic expression cannot be combined when numerical values have not been assigned to the literal factors. For example,  $-5x^2 + 3xy - 8y^2$  contains three dissimilar terms. This expression cannot be further simplified by combining terms through addition or subtraction.

### Symbols of Grouping

To group two or more terms to indicate that they are to be considered and treated as though they were one term even though there may be plus and minus signs between them, use parentheses ( ) (which we have already used), brackets [ ], braces { }, and the vinculum  $\overline{\quad}$ . The vinculum is sometimes called the *over-score*, and is seldom used except in conjunction with a radical sign, such as in  $\sqrt{a+b}$ , or in a Boolean algebra expression. The fact that  $-7 + 2 - 5$  is to be subtracted from 15, for example, could be indicated in any one of the following ways:

$$15 - (-7 + 2 - 5)$$

$$15 - [-7 + 2 - 5]$$

$$15 - \{-7 + 2 - 5\}$$

$$15 - \overline{-7 + 2 - 5}$$

Parentheses are the most frequently used symbols of grouping. When several symbols are needed to avoid confusion in grouping, parentheses usually comprise the innermost symbols, followed by brackets, and then by braces as the outermost symbols. This arrangement of grouping symbols is illustrated as follows:

$$2x - \{3y + [-8 - 5y - (x-4)]\}$$

### Removing and Inserting Grouping Symbols

Rules governing the removal and insertion of all grouping symbols are the same, so the following discussion in terms of parentheses will serve as a basis for all.

**REMOVING PARENTHESES.**—If parentheses are preceded by a minus sign, the entire quantity enclosed must be regarded as a subtrahend. This means that each term of the quantity in parentheses is subtracted from the expression preceding the minus sign. You can remove parentheses preceded by a minus sign if you change the signs of all terms within the parentheses.

For example, if we subtract one number from another, we change the sign of the subtrahend and proceed as in addition. To subtract  $-7$  from 16, we change the sign of  $-7$  and proceed as in addition:  $16 - (-7) = 16 + 7 = 23$ .

If you look at the minus sign preceding the parentheses as a multiplier, you could work an expression such as  $-(4 - 3 + 2)$  as follows: Minus times plus is minus, so the first term of the expression with parentheses removed is  $-4$ . (Remember that the 4 in the original expression is understood to be a  $+4$ , since it has no sign showing.) Minus times minus is plus, so the second term is  $+3$ . Minus times plus is minus, so the third term is  $-2$ . The result is  $-4 + 3 - 2$ , which reduces to  $-3$ .

In an arithmetic expression, you can combine the numbers within the parentheses before applying the negative sign which precedes the parentheses, but in an algebraic expression with no like terms, the rule for removal of parentheses is applied as in this example:  $2a - (-4x + 3by) = 2a + 4x - 3by$ .

Parentheses preceded by a plus sign can be removed without any other changes, as the following example shows:  $2b + (a - b) = 2b + a - b = a + b$ .

Many expressions contain more than one set of parentheses, brackets, and other symbols of grouping. In removing these, you can proceed from the outside inward or from the inside outward. For the beginner, it is simpler to start on the inside and work toward the outside, as seen in the following example:

$$\begin{aligned} & 2a - [x + (x - 3a) - (9a - 5x)] \\ &= 2a - [x + x - 3a - 9a + 5x] \\ &= 2a - [7x - 12a] \\ &= 2a - 7x + 12a \\ &= 14a - 7x \end{aligned}$$

#### ENCLOSING TERMS IN PARENTHESES.—

To enclose a group of terms in parentheses preceded by a positive sign, the group of terms remains unchanged, as follows:

$3x - 2y + 7x - y = (3x - 2y) + (7x - y)$ . Note that this agrees with the rule for removing parentheses preceded by a plus sign.

If terms are enclosed within parentheses preceded by a minus sign, the signs of all the terms enclosed must be changed as in this example:  $3x - 2y + 7x - y = 3x - (2y - 7x + y)$ .

### EXPONENTS AND RADICALS

Another way of referring to exponents and radicals is as *powers* and *roots*. These terms are defined below.

#### Exponent Terms

*Factor* is one of two or more quantities that are multiplied together to obtain a product. When the same quantity is multiplied (used as a factor) more than once in an algebraic expression, that quantity, then called a *base*, can be written with a symbol called an *exponent* to indicate how many times the base is used as a factor or what the *power* of the base is in that expression. For example:  $a \cdot a \cdot a \cdot a = a^4$ , where  $a$  is the base, 4 is the exponent, and it is read “ $a$  to the 4th power.”

Exponent is a small number written to the right and slightly above a quantity (base) to indicate how many times the base is used as a factor; the exponent also represents the power of the base. For example:  $3^2 = 9$ , where 3 is the square root of 9 and 9 is the square of 3.

Base is the quantity being used as a factor more than once; the quantity being raised to a power. Raising to a power is another way of saying “using as a factor more than once.”

#### Radical Terms

When a number represents a base raised to a power, the base is said to be a *root* of the number. The root is indicated by the power of the base. For example, if the number 8 represents the base 2 raised to the 3rd power ( $8 = 2^3$ ), then 2, the base, is said to be the 3rd (or cube) root of the number 8. Tables have been derived for 2nd (or square) and 3rd roots of numbers; calculators also can determine roots. Any number may represent some base raised to a power; not all roots are whole numbers: for example, the square root of the number 8 is 2.828.

*Radical* is an indicated root of a quantity (number). The radical consists of a radical sign ( $\sqrt{\quad}$ ) and the quantity (number) under the radical sign, which is called the *radicand*. The radical sign consists of the symbol (extended by a vinculum or bar to cover the quantity or number) used to indicate a root.

*Root index* is a small number (3 for cube root, 4 for 4th root, etc.) placed in the notch of the radical sign to indicate which root is to be determined. Although a root index of 2 would indicate square root, the root index is normally omitted and the absence of a root index is understood to indicate square root. In,  $\sqrt[4]{6}$  it is the 4th root to be determined.

*Radicand* is the quantity (number) under the radical sign.

#### Operations of Exponents and Radicals

The rules of operation with exponents and radicals are the same in algebra as in arithmetic. For example,  $n^2 \cdot n^3 = n^{2+3} = n^5$ . Some care is necessary to avoid confusion over exponents such as  $3^2 \cdot 3^3$ . In this example,  $n = 3$  and the product desired is  $3^5$ , not  $9^5$ . In general,  $3^a \cdot 3^b = 3^{a+b}$ , and a similar result is reached whether the factor which acts as a base for the exponent is a number or a letter. The general form can be expressed as follows:  $n^a \cdot n^b = n^{a+b}$ .

### EVALUATING OPERATIONS INVOLVING MONOMIALS AND POLYNOMIALS

Many operations with monomials and polynomials, using both literal and numerical factors,

follow rules of arithmetic. Following are explanations for the various operations.

### Multiplying Monomials

If a monomial such as  $3abc$  is to be multiplied by a numerical multiplier, for example, 5, the coefficient alone is multiplied, as in  $5 \times 3abc = 15abc$ .

When the numerical factor is not the initial factor of the expression, as in  $x(2a)$ , the result of the multiplication is not written as  $x2a$ . Instead, the numerical factor is interchanged with literal factors by use of the commutative law of multiplication. The literal factors are usually interchanged to place them in alphabetical order, and the result is  $x(2a) = 2ax$ .

The rule for multiplication of monomials may be stated as follows: Multiply the numerical coefficients to form the coefficient of the product. Multiply the literal factors, combining exponents in like factors, to form the literal part of the product. The complete process is illustrated in the following example:

$$\begin{aligned}(2ab)(3a^2)(2b^3) &= 12a^{1+2} b^{1+3} \\ &= 12a^3b^4\end{aligned}$$

### Dividing Monomials

As may be expected, the process of dividing is the inverse of multiplying. Because  $3 \times 2a = 6a$ ,  $6a \div 3 = 2a$ , or  $6a \div 2 = 3a$ . Thus, when the divisor is numerical, divide the coefficient of the dividend by the divisor.

When the divisor contains literal parts that are also in the dividend, cancellation may be performed as in arithmetic. For example,  $6ab \div 3a$  may be written as follows:

$$\frac{(2)(3a)(b)}{3a}$$

Cancellation of the common literal factor,  $3a$ , from the numerator and denominator leaves  $2b$  as the answer.

When the same literal factors appear in both the divisor and the dividend, but with different exponents, cancellation may still be used, as follows:

$$\begin{aligned}\frac{14a^3b^3x}{-21a^2b^5x} &= \frac{(7)(2)a^2ab^3x}{(7)(-3)a^2b^3b^2x} \\ &= \frac{2a}{-3b^2} \\ &= -\frac{2a}{3b^2}\end{aligned}$$

This same problem may be solved without thinking in terms of cancellation, by rewriting with negative exponents as follows:

$$\begin{aligned}\frac{14a^3b^3x}{-21a^2b^5x} &= \frac{2a^{3-2}b^{3-5}x^{1-1}}{-3} \\ &= \frac{2ab^{-2}}{-3} \\ &= \frac{2a}{-3b^2} \\ &= -\frac{2a}{3b^2}\end{aligned}$$

### Operations with Polynomials

Adding and subtracting polynomials is simply adding and subtracting like terms. There is a great similarity between the operations with polynomials and denominate numbers. Compare the following examples:

Add 5 qt and 1 pt to 3 qt and 2 pt.

$$\begin{array}{r}3 \text{ qt} + 2 \text{ pt} \\ \underline{5 \text{ qt} + 1 \text{ pt}} \\ 8 \text{ qt} + 3 \text{ pt}\end{array}$$

Add  $5x + y$  to  $3x + 2y$ .

$$\begin{array}{r}3x + 2y \\ \underline{5x + y} \\ 8x + 3y\end{array}$$

One method of adding polynomials (shown in the above examples) is to place like terms in columns and to find the algebraic sum of the like terms. For example, to add  $3a + b - 3c$ ,  $3b + c - d$ , and  $2a + 4d$ , arrange the polynomials as follows:

$$\begin{array}{r}3a + b - 3c \\ 3b + c - d \\ \underline{2a \qquad \qquad + 4d} \\ 5a + 4b - 2c + 3d\end{array}$$

Subtraction can be done the same way, by placing terms of the subtrahend under the like terms of the minuend and carrying out the subtraction. Remember, in subtraction, the signs of all the terms of the subtrahend must first be mentally changed and then the process completed as in addition. For example, subtract  $10a + b$  from  $8a - 2b$ , as follows:

$$\begin{array}{r}8a - 2b \\ \underline{10a + b} \\ -2a - 3b\end{array}$$

Again, note the similarity between this type of subtraction and the subtraction of denominate numbers.

Addition and subtraction of polynomials also can be indicated with the aid of symbols of grouping. The rule regarding changes of sign when removing parentheses preceded by a minus sign automatically takes care of subtraction. For example, to subtract  $10a + b$  from  $8a - 2b$ , we can use the following arrangement:

$$\begin{aligned}(8a - 2b) - (10a + b) &= 8a - 2b - 10a - b \\ &= -2a - 3b\end{aligned}$$

Similarly, to add  $-3x + 2y$  to  $-4x - 5y$ , we can write

$$\begin{aligned}(-3x + 2y) + (-4x - 5y) &= -3x + 2y - 4x - 5y \\ &= -7x - 3y\end{aligned}$$

### Multiplication of a Polynomial by a Monomial

We can explain the multiplication of a polynomial by a monomial by using an arithmetic example. To multiply the binomial expression  $7 - 2$  by  $4$ , we may write  $4 \times (7 - 2)$  or simply  $4(7 - 2)$ . Now  $7 - 2 = 5$ . Therefore,  $4(7 - 2) = 4(5) = 20$ . To solve the problem a different way, instead of subtracting first and then multiplying, multiply each term of the expression by  $4$  and then subtract. Thus,  $4(7 - 2) = (4 \times 7) - (4 \times 2) = 20$ . Both methods give the same result. The second method makes use of the distributive law of multiplication.

When there are literal parts in the expression to be multiplied, the first method cannot be used and the distributive method must be employed. For example:

$$\begin{aligned}4(5 + a) &= 20 + 4a \\ 3(a + b) &= 3a + 3b \\ ab(x + y - z) &= abx + aby - abz\end{aligned}$$

Thus, to multiply a polynomial by a monomial, multiply each term of the polynomial by the monomial.

### Multiplication of a Polynomial by a Polynomial

As with the monomial multiplier, we explain the multiplication of a polynomial by a polynomial by use of an arithmetic example. To multiply  $(3 + 2)(6 - 4)$ , we could do the operation within the parentheses first and then multiply, as follows:

$$(3 + 2)(6 - 4) = (5)(2) = 10$$

However, thinking of the quantity  $(3 + 2)$  as one term, we can use the method described for a monomial multiplier. That is, we can multiply each term of the multiplicand by the multiplier,  $(3 + 2)$ , as follows:  $(3 + 2)(6 - 4) = [(3 + 2) \times 6 - (3 + 2) \times 4]$ .

Now, considering each of the two resulting products separately, we note that each is a binomial multiplied by a monomial.

$$\text{The first is: } (3 + 2)6 = (3 \times 6) + (2 \times 6)$$

and the second is:

$$-(3 + 2)4 = -[(3 \times 4) + (2 \times 4)] = -(3 \times 4) - (2 \times 4)$$

Thus we have:

$$\begin{aligned}(3 + 2)(6 - 4) &= (3 \times 6) + (2 \times 6) - (3 \times 4) - (2 \times 4) \\ &= 18 + 12 - 12 - 8 \\ &= 10\end{aligned}$$

The complete product is formed by multiplying each term of the multiplicand separately by each term of the multiplier and combining the results.

Now let us apply this method in two examples involving literal numbers.

$$(a + b)(m + n) = am + an + bm + bn$$

$$(2b + c)(r + s + 3t - u) = 2br + 2bs + 6bt - 2bu + cr + cs + 3ct - cu$$

The rule governing these examples is as follows: The product of any two polynomials is found by multiplying each term of one by each term of the other and adding the results algebraically.

It is often convenient, especially when either of the expressions contains more than two terms, to place the polynomial with the fewer terms beneath the other polynomial and multiply term by term beginning at the left. Like terms of the partial products are placed one beneath the other to facilitate addition.

Suppose we wish to find the product of  $3x^2 - 7x - 9$  and  $2x - 3$ . The procedure is

$$\begin{array}{r} 3x^2 - 7x - 9 \\ \quad \quad \quad 2x - 3 \\ \hline 6x^3 - 14x^2 - 18x \\ \quad \quad -9x^2 + 21x + 27 \\ \hline 6x^3 - 23x^2 + 3x + 27 \end{array}$$

### Division of a Polynomial by a Monomial

Division, like multiplication, may be distributive. Consider, for example, the problem  $(4 + 6 - 2) \div 2$ , which may be solved by adding the numbers within the parentheses and then dividing the total by 2. Thus,

$$\frac{4 + 6 - 2}{2} = \frac{8}{2} = 4$$

Notice that the problem also may be solved by the distributive method.

$$\begin{aligned}\frac{4+6-2}{2} &= \frac{4}{2} + \frac{6}{2} - \frac{2}{2} \\ &= 2 + 3 - 1 \\ &= 4\end{aligned}$$

Do not confuse problems of the type just described with another type that is similar in appearance but not in final result. For example, in a problem such as  $2 \div (4 + 6 - 2)$  the beginner is tempted to divide 2 successively by 4, then 6, and then  $-2$ , as follows:

$$\frac{2}{4+6-2} \neq \frac{2}{4} + \frac{2}{6} - \frac{2}{2}$$

Notice that we have canceled the “equals” sign, because  $2 \div 8$  is obviously not equal to  $\frac{1}{2} + \frac{2}{6} - 1$ . The distributive method applies only in those cases in which several different numerators are to be used with the same denominator.

When literal numbers are present in an expression, the distributive method must be used, as in the following two problems:

$$\begin{aligned}\frac{2ax + aby + a}{a} &= \frac{2ax}{a} + \frac{aby}{a} + \frac{a}{a} \\ &= 2x + by + 1\end{aligned}$$

and

$$\begin{aligned}\frac{18ab^2 - 12bc}{6b} &= \frac{18ab^2}{6b} - \frac{12bc}{6b} \\ &= 3ab - 2c\end{aligned}$$

This division may be done mentally, and the intermediate steps need not be written out.

### Division of a Polynomial by a Polynomial

Division of one polynomial by another proceeds as follows:

1. Arrange both the dividend and the divisor in either descending or ascending powers of the same letter.

2. Divide the first term of the dividend by the first term of the divisor and write the result as the first term of the quotient.

3. Multiply the complete divisor by the quotient just obtained, write the terms of the product under the like terms of the dividend, and subtract this expression from the dividend.

4. Consider the remainder as a new dividend and repeat steps 1, 2, and 3.

Example:

$$(10x^3 - 7x^2y - 16xy + 12y^3) \div (5x - 6y)$$

Solution:

$$\begin{array}{r} 2x^2 + xy - 2y^2 \\ 5x - 6y \overline{) 10x^3 - 7x^2y - 16xy + 12y^3} \\ \underline{10x^3 - 12x^2y} \phantom{+ 12y^3} \\ 5x^2y - 16xy^2 \phantom{+ 12y^3} \\ \underline{5x^2y - 6xy^2} \phantom{+ 12y^3} \\ -10xy^2 + 12y^3 \\ \underline{-10xy^2 + 12y^3} \\ \hline \hline \end{array}$$

In the example just shown, we began by dividing the first term,  $10x^3$ , of the dividend by the first term,  $5x$ , of the divisor. The result is  $2x^2$ . This is the first term of the quotient.

Next, we multiply the divisor by  $2x^2$  and subtract this product from the dividend. Use the remainder as a new dividend. Get the second term,  $xy$ , in the quotient by dividing the first term,  $5x^2y$ , of the new dividend by the first term,  $5x$ , of the divisor. Multiply the divisor by  $xy$  and again subtract from the dividend.

Continue the process until the remainder is zero or is of a degree lower than the divisor. In the example being considered, the remainder is zero (indicated by the double line at the bottom). The quotient is  $2x^2 + xy - 2y^2$ .

The following long division problem is an example in which a remainder is produced:

$$\begin{array}{r} x^2 - x + 3 \\ x + 3 \overline{) x^3 + 2x^2} \phantom{+ 5} \\ \underline{x^3 + 3x^2} \phantom{+ 5} \\ -x^2 \phantom{+ 5} \\ \underline{-x^2 - 3x} \phantom{+ 5} \\ 3x + 5 \\ \underline{3x + 9} \\ -4 \end{array}$$

The remainder is  $-4$ .

Notice that the term  $-3x$  in the second step of this problem is subtracted from zero, since there is no term containing  $x$  in the dividend. When writing down a dividend for long division, leave spaces for missing terms that may enter during the long division process.

In arithmetic, division problems are often arranged as follows, in order to emphasize the relationship between the remainder and the divisor:

$$\frac{5}{2} = 2 + \frac{1}{2}$$

This same type of arrangement is used in algebra. For example, in the problem just shown, the results could be written as follows:

$$\frac{x^3 + 2x^2 + 5}{x + 3} = x^2 - x + 3 - \frac{4}{x + 3}$$

Remember, before dividing polynomials, arrange the terms in the dividend and divisor according to either descending or ascending powers of one of the literal numbers. When only one literal number occurs, the terms are usually arranged in descending powers.

For example, in the polynomial  $2x^2 + 4x^3 + 5 - 7x$  the highest power among the literal terms is  $x^3$ . If the terms are arranged according to descending powers of  $x$ , the term in  $x^3$  should be followed by the  $x^2$  term, the  $x$  term, and finally the constant term. The polynomial arranged according to descending powers of  $x$  is  $4x^3 + 2x^2 - 7x + 5$ .

Suppose that  $4ab + b^2 + 15a^2$  is to be divided by  $3a + 2b$ . Since  $3a$  can be divided evenly into  $15a^2$ , arrange the terms according to descending powers of  $a$ . The dividend takes the form  $15a^2 + 4ab + b^2$ .

### Special Products

The products of certain binomials occur frequently. It is convenient to remember the form of these products so that they can be written immediately without performing the complete multiplication process. Four such special products follow, showing how each is derived:

Product of the sum and difference of two numbers:  
 $(x - y)(x + y) = x^2 - y^2$

Square of the sum of two numbers:  
 $(x + y)^2 = x^2 + 2xy + y^2$

Square of the difference of two numbers:  
 $(x - y)^2 = x^2 - 2xy + y^2$

Product of two binomials having a common term:  
 $(x + a)(x + b) = x^2 + (a + b)x + ab$

**PRODUCT OF SUM AND DIFFERENCE.**—The product of the sum and difference of two numbers

is equal to the square of the first number minus the square of the second number. If, for example,  $x - y$  is multiplied by  $x + y$ , the middle terms cancel one another. The result is the square of  $x$  minus the square of  $y$ , as shown in the following example:

$$\begin{array}{r} x - y \\ \times x + y \\ \hline x^2 - xy \\ \quad + xy - y^2 \\ \hline x^2 - y^2 \end{array}$$

By keeping this rule in mind, the product of the sum and difference of two numbers can be written down immediately by writing the difference of the squares of the numbers. For example, consider the following three problems:

$$\begin{aligned} (x + 3)(x - 3) &= x^2 - 3^2 = x^2 - 9 \\ (5a + 2b)(5a - 2b) &= (5a)^2 - (2b)^2 = 25a^2 - 4b^2 \\ (7x + 4y)(7x - 4y) &= 49x^2 - 16y^2 \end{aligned}$$

**SQUARE OF SUM OR DIFFERENCE.**—The square of the sum of two numbers is equal to the square of the first number plus twice the product of the numbers plus the square of the second number, as shown in the following example:

$$\begin{array}{r} (x + y)^2 = x^2 + 2xy + y^2, \text{ or} \\ x + y \\ \times x + y \\ \hline xy + y^2 \\ \hline x^2 + 2xy + y^2 \end{array}$$

The square of the difference of the same two numbers has the same form, except that the sign of the middle term is negative, as shown in the following example:

$$\begin{array}{r} (x - y)^2 = x^2 - 2xy + y^2, \text{ or} \\ x - y \\ \times x - y \\ \hline -xy + y^2 \\ \hline x^2 - 2xy + y^2 \end{array}$$

**BINOMIALS HAVING A COMMON TERM.**—The binomials  $x + a$  and  $x + b$  have a common term,  $x$ . They have two unlike terms,  $+a$  and  $+b$ . The product of these binomials is:

$$\begin{array}{r} x + a \\ x + b \\ \hline x^2 + ax \\ + bx + ab \\ \hline x^2 + ax + bx + ab = x^2 + (a + b)x + ab \end{array}$$

The product is obtained by squaring the common term, adding the sum of the unlike terms multiplied by the common term, and finally adding the product of the unlike terms.

Q1-21. The algebraic form of  $a(b + c) = ab + ac$ , is referring to which of the following laws?

1. Commutative
2. Associative
3. Distributive
4. Literal

Q1-22. Evaluate the algebraic expression  $3x + 7y - c$  when  $c = 3$ ,  $x = 7$ , and  $y = 5$ .

1. 53
2. 56
3. -53
4. -56

Q1-23. Which of the following terms is a binomial?

1.  $x$
2.  $ab$
3.  $3y + a$
4.  $3 - y^2 + a$

Q1-24. Combine like terms in the expression  $y + y^2 + 2y$ .

1.  $3y^2$
2.  $3y^3$
3.  $y^2 + 3y$
4.  $2y^2 + 2y$

Q1-25. Remove the symbols of grouping and combine like terms from  $-a + [-a - (2a + 3)] + 3$ .

1.  $a + -a - 2a + 3 + 3$
2.  $-4a$
3.  $-10a$
4.  $-4a + 6$

Q1-26. Which of the following terms refers to the number 4 in the example  $\sqrt[4]{28}$ ?

1. Radicand
2. Exponent
3. Root
4. Root index

Q1-27. Considering the rule for exponents, the expression  $b^2 \cdot b^3$  is equal to which of the following?

1.  $2b^5$
2.  $2b^6$
3.  $b^6$
4.  $b^5$

Q1-28. Multiplication of the monomials  $(-5ab^2)(2a^2b)$  produces which of the following products?

1.  $-10a^3b^3$
2.  $10a^3b^3$
3.  $-3a^3b^3$
4.  $-3ab^4$

Q1-29.  $a^9b^4 \div a^6b^3$  produces which of the following quotients?

1.  $a^6b^{-2}$
2.  $a^3b$
3.  $a^3$
4.  $ab^3$

Q1-30. Perform the indicated operation and combine like terms for  $(2a + b) - (3a + 5b)$ .

1.  $-(5a + b)$
2.  $a + 4b$
3.  $-(a + 4b)$
4.  $5a + b$

Q1-31. Considering multiplication of a polynomial by a monomial, solve for  $2a^3(a^2 - ab)$ .

1.  $2a^5 - 2a^4b$
2.  $2a^5 - 2ab^4$
3.  $2a^6 - 2a^3b$
4.  $2a^6 - 2ab^3$

Q1-32. Which of the following is the product for  $(2a - 3)(a + 2)$ ?

1.  $2a + a^2 + 6$
2.  $2a^2 - a + 6$
3.  $2a + a^2 - 6$
4.  $2a^2 + a - 6$

Q1-33. Which of the following is the quotient for  $(a^3 - 3a^2 + a) \div a$ ?

1.  $a^2 - 3a^2$
2.  $a^2 - 3a + 1$
3.  $a^4 - 3a^2 + 1$
4.  $a^2 + 3a - 1$

Q1-34. Which of the following is the quotient for  $(x^2 + 11x + 30) \div (x + 6)$ ?

1.  $x + 5$
2.  $5x + 30$
3.  $35x$
4.  $5x^2$

## POWERS OF TEN AND SCIENTIFIC NOTATION

**LEARNING OBJECTIVES:** Recognize powers of ten and scientific notation. Convert between powers of ten and scientific notation. Solve mathematical problems that involve powers of ten and scientific notation.

Powers of ten and scientific notation are closely related subjects, both involving powers of ten, but the special nature of scientific notation warrants giving it its own title.

Understanding powers of ten and scientific notation is essential to the study of physics and electronics. Learning the material in this lesson topic will help avoid problems of misplacing decimal points in calculations, spending too much time on basic mathematical problems, and misinterpreting meter readings.

Powers of ten and scientific notation allow easier and faster manipulation of very large and very small numbers, as the use of scientific notation makes it much easier to determine decimal point placement in the final results. Powers of ten also provide a basis for the use of various metric units' prefixes.

## TERMS AND DEFINITIONS

A *power of ten* is the value 10 raised to a power; it is expressed as 10 with an indicated positive or negative exponent.

*Scientific notation* is a representation of any number, large or small, as a number between 1 and 10, multiplied by a power of ten.

One of the most important advantages of scientific notation is the fact that it simplifies the task of determining the number of significant digits in a number.

Example: The fact that the number .00045 has two significant digits is obscured by the presence of the 0's. The confusion can be avoided by writing the number in scientific notation as follows:  $.00045 = 4.5 \times 10^{-4}$ .

For the number 12,358,  $123.58 \times 10^2$  or  $12.358 \times 10^3$  are both examples of numbers expressed with powers of ten. However, only  $1.2358 \times 10^4$  is an example expressed in scientific notation since it is the only one that is expressed as a number between 1 and 10 multiplied by a power of ten.

## CONVERTING TO SCIENTIFIC NOTATION

Shift the decimal point to a position immediately to the right of the first significant digit in the number. This position of the decimal point is called standard position.

The number of digits between the new (standard) position of the decimal point and its original position becomes the power of 10 in the number expressed in scientific notation.

If the decimal point is shifted to the left, the sign of the power of ten is positive; if the point is shifted to the right, the sign of the power of ten is negative.

For example: 342.6 expressed in scientific notation becomes  $3.426 \times 10^2$ , and 0.003426 expressed in scientific notation becomes  $3.426 \times 10^{-3}$ .

## CONVERSION FROM ONE POWER OF TEN FORM TO ANOTHER

Certain powers of ten numbers, when used with physical quantities such as volts, amperes, grams, etc. are expressed with metric prefixes and/or their abbreviations, as seen in table 1-1.

If the value is expressed in metric-prefix form, convert the value to its power of ten form. Shift the decimal point and change the power of ten as necessary



**Table 1-1.—Metric Prefixes for Powers of Ten**

$1 \times 10^{12}$	tera	T = 1,000,000,000,000
$1 \times 10^9$	giga	G = 1,000,000,000
$1 \times 10^6$	mega	M = 1,000,000
$1 \times 10^3$	kilo	k = 1,000
$1 \times 10^0$	base	
$1 \times 10^{-3}$	milli	m = 0.001
$1 \times 10^{-6}$	micro	$\mu$ = 0.000001
$1 \times 10^{-9}$	nano	n = 0.000000001
$1 \times 10^{-12}$	pico	p = 0.000000000001

to satisfy the conversion to the new metric-prefix form. The value can then be expressed in its new metric-prefix form.

Example: Convert  $0.752\text{M}\Omega$  to  $\text{k}\Omega$  ( $\Omega$  = ohm)

$$\begin{aligned} 0.752\text{M}\Omega &= .752 \times 10^6 \\ &= 752 \times 10^3 \\ &= 752\text{k}\Omega \end{aligned}$$

### **MATHEMATICAL OPERATIONS INVOLVING NUMBERS EXPRESSED AS POWERS OF TEN**

For addition and subtraction: First, shift the decimal point to make all powers of ten equal. Then perform the indicated addition or subtraction and retain the power of ten in the answer.

Example:

$$42.56 \times 10^3 + 23.5 \times 10^2 = 42.56 \times 10^3 + 2.35 \times 10^3 = 44.91 \times 10^3$$

For multiplication: Perform the multiplication operation algebraically, adding the exponents of the powers of ten.

Example:

$$(3.5 \times 10^2)(4.23 \times 10^3) = 14.805 \times 10^{2+3} = 14.805 \times 10^5$$

For division: Perform the division operation algebraically, subtracting the exponent of the power of ten of the divisor from the exponent of the power of ten of the dividend.

Example:

$$\frac{(15.45 \times 10^4)}{(5.25 \times 10^2)} = 2.94 \times 10^{4-2} = 2.94 \times 10^2$$

*Q1-35. Which of the following numbers is a number expressed in scientific notation?*

1.  $.0875 \times 10^4$
2.  $0.875 \times 10^3$
3.  $8.75 \times 10^2$
4.  $87.5 \times 10^1$

*Q1-36. Which of the following numbers is equal to 634.9 expressed in scientific notation?*

1.  $0.6349 \times 10^3$
2.  $6349 \times 10^{-1}$
3.  $6.349 \times 10^{-2}$
4.  $6.349 \times 10^2$

Q1-37. 72.5  $\mu$  volts is equal to how many m volts?

1. 0.00725
2. 0.0725
3. 0.725
4. 7.25

Q1-38. Which of the following is the correct sum for  $0.3 \times 10^5 + 12.01 \times 10^4$ ?

1.  $1.501 \times 10^5$
2.  $12.31 \times 10^9$
3.  $150.1 \times 10^4$
4.  $15.01 \times 10^5$

Q1-39. Which of the following is the correct product for  $(4.6 \times 10^3)(2 \times 10^4)$ ?

1.  $0.092 \times 10^{12}$
2.  $0.092 \times 10^7$
3.  $9.2 \times 10^{12}$
4.  $9.2 \times 10^7$

Q1-40. Which of the following is the correct quotient for  $(21.4 \times 10^6) \div (2 \times 10^2)$ ?

1.  $10.7 \times 10^3$
2.  $10.7 \times 10^4$
3.  $1.07 \times 10^8$
4.  $10.7 \times 10^8$

## CHAPTER 1

### ANSWERS TO REVIEW QUESTIONS

A1-1. Denominator

A1-2. False

$$A1-3. 2\frac{2}{5}$$

$$A1-4. \frac{55}{16}$$

$$A1-5. \frac{1}{4}$$

$$A1-6. 2\frac{3}{16}$$

$$A1-7. \frac{17}{32}$$

$$A1-8. \frac{1}{15}$$

$$A1-9. \frac{2}{5}$$

$$A1-10. 1\frac{1}{4} \text{ ohms}$$

$$A1-11. |6|$$

$$A1-12. 9 > 5$$

$$A1-13. -10$$

$$A1-14. +2$$

$$A1-15. +2$$

$$A1-16. -42$$

$$A1-17. +20$$

$$A1-18. -3$$

A1-19. True

$$A1-20. -\frac{15}{5}$$

A1-21. Distributive

$$A1-22. 53$$

$$A1-23. 3y + a$$

$$A1-24. y^2 + 3y$$

$$A1-25. -4a$$

A1-26. Root index

$$A1-27. b^5$$

$$A1-28. -10a^3b^3$$

$$A1-29. a^3b$$

$$A1-30. -(a + 4b)$$

$$A1-31. 2a^5 - 2a^4b$$

$$A1-32. 2a^2 + a - 6$$

$$A1-33. a^2 - 3a + 1$$

$$A1-34. x + 5$$

$$A1-35. 8.75 \times 10^2$$

$$A1-36. 6.349 \times 10^2$$

$$A1-37. 0.0725$$

$$A1-38. 1.501 \times 10^5$$

$$A1-39. 9.2 \times 10^7$$

$$A1-40. 10.7 \times 10^4$$



## CHAPTER 2

# MATHEMATICS - APPLICATIONS

Equations and formulas have a wide and varied use throughout the fields of electricity and electronics. Expressing real problems in mathematical terms to form equations and then solving the equations mathematically allows you to solve the real problems you encounter on the job.

### EQUATIONS AND FORMULAS

**LEARNING OBJECTIVES:** Define the terms associated with equations. Solve linear equations. Solve literal equations. Differentiate between equations and formulas. Derive new formulas by manipulating original formulas.

One of the principal reasons for the study of polynomials, grouping symbols, factors, etc., is to prepare for solving equations.

An *equation* is a statement that two expressions are equal in value. An equation can be compared to a balance scale with equal or equivalent weights on each side. The sides may be referred to as left and right members. As in the case of a scale, any change made to one member must be accompanied by an equal or equivalent change to the other member, or the scale will not balance. Mathematical operations on equations are based on the same principle.

*Formulas* are special cases of equations. The formula is a general fact, rule, or principle expressed in algebraic symbols as an equation.

### EQUATIONS

Definitions of some of the terms used in equations are as follows:

A *constant* is a quantity whose value remains the same throughout a particular problem.

A *fixed constant* is one whose value never changes, for example, 5, 3,  $\pi$ , etc.

An *arbitrary (literal) constant* is one that can be assigned different values for different problems. It normally is represented by letters from the beginning of the alphabet, such as  $a$ ,  $b$ ,  $c$ , etc.

A *variable* is a quantity whose value is free to change. It is normally represented by letters from the end of the alphabet, such as  $x$ ,  $y$ ,  $z$ .

An *equation* is a statement, usually symbols, that two quantities or mathematical expressions are equal. A *numerical equation* contains only numbers, for example,  $2 + 3 = 6 - 1$ . A *literal equation* contains arbitrary or literal constants such as  $x + 3 = 6 - y$ .

The degree of an equation is the highest power of the variable in any term in the equation (as long as only one variable exists per term). First degree equations are called *linear equations*; second degree equations (quadratic) and third degree equations (cubic) will not be covered here.

### Solving Linear Equations

Solving an equation is finding the value of the variable that makes the equation true. That value is said to satisfy the equation and is the solution to the equation.

As a rule, if both members of an equation are added to, subtracted from, multiplied, or divided equally, the resulting members will still be equal. (Division by zero is excluded.)

An equation must always be kept in balance or the equality is lost. We use the above rule to remove or adjust terms and coefficients until the value of the variable is discovered. Some examples of equations solved by means of the four operations mentioned in the rule follow.

Using addition, find the value of  $x$  in the equation  $x - 3 = 12$ . As in any equation, we must isolate the variable on either the right or left side. In this problem, we leave the variable on the left and perform the following steps:

1. Add 3 to both members of the equation, in effect, undoing the subtraction indicated by the expression  $x - 3$ , for the purpose of isolating  $x$  in the left member.

$$x - 3 + 3 = 12 + 3$$

2. Combining the terms, we find  $x = 15$ .

Using subtraction, find the value of  $x$  in the equation  $x + 14 = 24$ .

1. Subtract 14 from each member. In effect, this undoes the addition indicated in the expression  $x + 14$ .

$$x + 14 - 14 = 24 - 14$$

2. Combining the terms, we have  $x = 10$ .

Using multiplication, find the value of  $y$  in the equation  $\frac{y}{5} = 10$ .

1. The only way to remove the 5 so that the  $y$  can be isolated is to undo the indicated division. We use multiplication, the inverse of division, by multiplying both members by 5.

$$5\left(\frac{y}{5}\right) = 5(10)$$

2. Performing the indicated multiplication, we have  $y = 50$ .

Using division, find the value of  $x$  in the equation  $3x = 15$ .

1. The multiplier 3 may be removed from the  $x$  by dividing the left member by 3. This must be balanced by dividing the right member by 3 also.

$$\frac{3x}{3} = \frac{15}{3}$$

2. Performing the indicated division, we have  $x = 5$ .

Most equations involve more than one step in their solutions like the simple equations just described, but the basic operations remain unchanged. If the basic rules are kept in mind, these complicated equations will not be difficult. Equations may require one or all of the basic operations before a solution can be obtained.

Using subtraction and division, find the value of  $x$  in the equation  $2x + 4 = 16$ .

1. The term containing  $x$  is isolated on the left by subtracting 4 from the left member. This operation must be balanced by also subtracting 4 from the right member.

$$2x + 4 - 4 = 16 - 4$$

2. Performing the indicated operation, we have  $2x = 12$ .

3. The multiplier 2 is removed from the  $x$  by dividing both sides of the equation by 2, as follows:

$$\frac{2x}{2} = \frac{12}{2}$$
$$x = 6$$

Using addition, multiplication, and division, find the value of  $y$  in the equation

$$\frac{3y}{2} - 4 = 11$$

1. Isolate the term containing  $y$  on the left by adding 4 to both sides.

$$\frac{3y}{2} - 4 + 4 = 11 + 4$$

$$\frac{3y}{2} = 15$$

2. Since the 2 will not divide the 3 exactly, multiply both members by 2 to eliminate the fraction.

$$2\left(\frac{3y}{2}\right) = 2(15)$$

$$3y = 30$$

3. Divide both members by 3 in order to isolate the  $y$  in the left member.

$$\frac{3y}{3} = \frac{30}{3}$$
$$y = 10$$

You also may have to solve equations having the variable in more than one term. Find the value of  $x$  in the equation  $\frac{3x}{4} + x = 12 - x$ .

1. Rewrite the equation with no terms containing the variable in the right member. This requires adding  $x$  to the right member to eliminate the  $-x$  term, and balance requires that we also add  $x$  to the left member.

$$\frac{3x}{4} + x + x = 12 - x + x$$

$$\frac{3x}{4} + 2x = 12$$

2. Since the 4 will not divide the 3 exactly, it is necessary to multiply the term by 4 to eliminate the fraction. However, notice that this multiplication cannot be performed on the first term only; any multiplier which is introduced for simplification purposes must be applied to the entire equation. Thus, each term in the equation is multiplied by 4 as follows:

$$4\left(\frac{3x}{4}\right) + 4(2x) = 4(12)$$

$$3x + 8x = 48$$

3. Add the terms containing  $x$  and then divide both sides by 11 to isolate the  $x$  in the left member, as follows:

$$11x = 48$$

$$x = \frac{48}{11}$$

$$x = 4\frac{4}{11}$$

### Solving Literal Equations

As stated earlier, the first letters of the alphabet usually represent known quantities (constants), and the last letters represent unknown quantities (variables). Thus, we usually solve for  $x$ ,  $y$ , or  $z$ .

Solve the literal equation  $\frac{x}{c} - a = b$  using the general rules for solving:

1. Multiply by  $c$  to remove the fraction.

$$c\left(\frac{x}{c}\right) - c(a) = c(b)$$

$$x - ac = bc$$

2. Now add  $ac$  to isolate  $x$ .

$$x - ac + ac = bc + ac$$

$$x = ac + bc$$

3. This is normally written  $x = c(a + b)$ .

### FORMULAS

One of the most common uses of algebra is in the solution of formulas. It is important to know how formulas are derived, how to translate them into words, how to make them from word statements, and how to use them to solve real problems.

A *formula* is a general fact, rule, or principle expressed in algebraic symbols. Formulas are a shorthand expression of a rule in which letters and signs of operation take the place of words. The formula always indicates the mathematical operations involved.

For example, the formula  $P = 2L + 2W$  indicates that the perimeter (sum of the lengths of the sides) of a rectangle is equal to twice its length plus twice its width, as seen in the following:

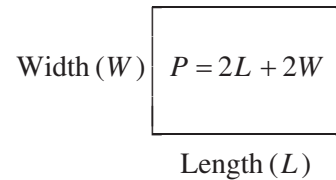

All formulas are equations, but not all equations are formulas. The equation may not have a subject, while the formula typically does. In the formula, the unknown quantity stands alone in the left-hand member. No computation is performed upon it, and it does not appear more than once. In the equation, on the other hand, the unknown quantity may appear once or more in either or both members, and computation may be performed with it or on it. We evaluate a formula by substituting for the literal numbers in the right member. An equation is solved by computation in either or both members until all that remains is an unknown quantity in one member and a known quantity in the other. The solution of an equation usually requires the knowledge of algebraic principles, while the evaluation of a formula may ordinarily be accomplished with only knowledge of arithmetic.

Letters that represent words have been standardized in many cases so that certain formulas may be written the same in various texts and reference books. However, to avoid any misunderstanding, a short explanation often accompanies formulas as follows:

$A = hw$ , where  $A$  = area in square units,  $h$  = height, and  $w$  = width.

Subscripts are used in a formula in which two or more of the same kinds of letters are being compared, where it is desirable to make a distinction between them. In electronics, for example, a distinction between resistances may be indicated by  $R_a$  and  $R_b$  or  $R_1$  and  $R_2$ . These small numbers or letters written to the right and below the  $R$ 's are called subscripts. Those shown here are read:  $R$  sub  $a$ ,  $R$  sub  $b$ ,  $R$  sub one, and  $R$  sub two. For example, to figure the total resistance ( $R_t$ ) in a parallel circuit the formula is as follows:

$$\frac{1}{R_t} = \frac{1}{R_1} + \frac{1}{R_2} + \frac{1}{R_3} + \dots$$

Refer to figure 2-1. Substitute the value of the resistors for  $R_1$ ,  $R_2$ , and  $R_3$ .

$$\frac{1}{R_t} = \frac{1}{5} + \frac{1}{20} + \frac{1}{10}$$

$$\frac{1}{R_t} = .35$$

$$R_t = 2.85\Omega$$

If values are given for all but one of its variables, a formula can be solved to obtain the value of that variable. The first step is usually the rearranging of the formula so that the unknown value is the subject—that is, a new formula is derived from the original. For example, the formula known as Ohm's law states that the electrical current ( $I$ ) flowing through a given resistance ( $R$ ) is equal to the applied voltage ( $E$ ) divided by the resistance is usually written

$$I = \frac{E}{R}$$

Suppose that instead of the current we wish to know the applied voltage or the resistance. We simply change the subject of the formula by the algebraic means discussed earlier in this chapter. Thus, in solving the formula for  $E$ , we multiply both sides by  $R$ , with the following result:

$$(R)I = \left(\frac{E}{R}\right)R$$

$$RI = E, \text{ or } E = IR$$

This formula states that the applied voltage is equal to the electrical current multiplied by the resistance. Likewise, in solving for resistance, we have the following:

$$\frac{E}{I} = \frac{IR}{I}$$

$$\frac{E}{I} = R \text{ or } R = \frac{E}{I}$$

This formula states that resistance is equal to the applied voltage divided by the electrical current.

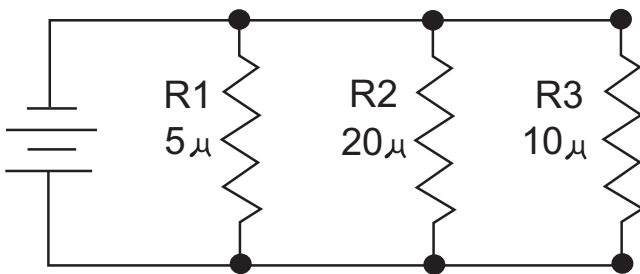

ATF02001

Figure 2-1.—Resistors in a parallel circuit.

We basically have two new formulas, the subject of one being applied voltage and the subject of the other being resistance. They are related to the original formula because they were derived from it, but they are different because they have different subjects.

Q2-1.  $A(n)$  \_\_\_\_\_ is a quantity whose value is free to change. It is normally represented by letters from the end of the alphabet, such as  $x$ ,  $y$ ,  $z$ .

Q2-2.  $A(n)$  \_\_\_\_\_ is a statement, usually symbols, that two quantities or mathematical expressions are equal.

Q2-3. Which of the following is the value of  $x$  in the equation  $\frac{1}{2}x - 2x = 25 + x$ ?

1. 10
2. -10
3. 24
4. -24

Q2-4. Which of the following is the value of  $x$  in the equation  $\frac{x}{a} + c = b$ ?

1.  $x = c(a + b)$
2.  $x = a(b + c)$
3.  $x = c(a - b)$
4.  $x = a(b - c)$

Q2-5. In a formula, the unknown quantity is in which of the following locations?

1. Left member
2. Right member
3. Both members
4. Neither member

Q2-6. Manipulate the formula  $A = \frac{1}{2}bh$ , and solve for the height ( $h$ ) of a triangle when the area ( $A$ ) = 24 square inches and the base ( $b$ ) = 6 inches.

1. 4 inches
2. 6 inches
3. 8 inches
4. 10 inches



## RATIOS, PROPORTIONS, AND VARIATIONS

**LEARNING OBJECTIVES:** Define ratios, proportions, and variations. Perform mathematical operations involving ratios, proportions, and variations.

The solution of problems based on ratio, proportion, and variation involves no new principles. However, familiarity with these topics often will lead to quick and simple solutions to problems that would otherwise be more complicated.

### RATIOS

The results of observation or measurement often must be compared with some standard value in order to have any meaning. For example, to say that a person can read 400 words per minute has little meaning as it stands. However, when that rate is compared to the 250 words per minute of the average reader, one can see that person reads considerably faster than the average reader does. How much faster? To find out, the rate is divided by the average rate, as follows:

$$\frac{400}{250} = \frac{8}{5}$$

Thus, for every 5 words read by the average reader, this person reads 8. Another way of making this comparison is to say that they read  $1\frac{3}{5}$  times faster than the average reader.

When the relationship between two numbers is shown in this way, they are compared as a *ratio*. A *ratio* is a comparison of two like quantities. It is the quotient obtained by dividing the first number of a comparison by the second.

Comparisons may be stated in more than one way. For example, if one gear has 40 teeth and another has 10, one way of stating the comparison would be 40 teeth to 10 teeth. This comparison could be shown as a ratio in two ways, as 40:10, or as  $\frac{40}{10}$ . When the emphasis is on ratio, these expressions would be read, the ratio of 40 to 10.

Percentage represents a special case of ratio, where 10% or 25% means the comparison of 10 or 25 to 100, as in  $\frac{10}{100}$  or  $\frac{25}{100}$ .

Comparison by means of a ratio is limited to quantities of the same kind. For example, in order to

express the ratio between 6 feet (ft) and 3 yards (yd), both quantities must be written in terms of the same unit. Thus the proper form of this ratio is 2 yd:3 yd, not 6 ft:3 yd. When the parts of the ratio are expressed in terms of the same unit, the units cancel each other and the ratio consists simply of two numbers. In this example, the final form of the ratio is 2:3.

Since a ratio is also a fraction, all the rules that govern fractions may be used in working with ratios. Thus, the terms may be reduced, increased, simplified, and so forth, according to the rules for fractions. To reduce the ratio 15:20 to lowest terms, write the ratio as a fraction and then proceed as for fractions. Thus, 15:20 becomes  $\frac{15}{20} = \frac{3}{4}$ . Hence, the ratio of 15 to 20 is the same as the ratio of 3 to 4.

Notice the distinction in the way we think about  $\frac{3}{4}$  as a fraction and  $\frac{3}{4}$  as a ratio. As a fraction, we think of it as the single quantity *three-fourths*. As a ratio, we think of it as a comparison between the two numbers, 3 and 4. For example, the lengths of two sides of a triangle are  $1\frac{9}{16}$  ft and 2 ft. To compare these lengths by means of a ratio, divide one number by the other and reduce to lowest terms, as follows:

$$\frac{1\frac{9}{16}}{2} = \frac{\frac{25}{16}}{2} = \frac{25}{16} \div \frac{2}{1} = \frac{25}{16} \times \frac{1}{2} = \frac{25}{32}$$

The two sides of the triangle compare as 25 to 32.

### PROPORTIONS

A *proportion* is an equation in which the members are ratios. A proportion may be expressed in either of the following forms:

1. As the equality of two fractions:  $\frac{a}{b} = \frac{c}{d}$
2. Alternate form:  $a:b = c:d$

In both cases, the proportion can be stated, *a* is to *b* as *c* is to *d*.

The first and fourth terms are called *extremes*, and the second and third terms are called the *means*. A quantity that appears as both means of a proportion is called the *mean proportional*. Let's look at the proportion 2:4 = 4:8. The terms 2 and 8 are the extremes and 4 is the mean proportional. It should be noted that the mean proportional between two numbers is the square root of their product. Thus,  $4 = \sqrt{2 \times 8}$ .

It also can be shown by successive multiplication and reduction of terms that the product of the means is equal to the product of the extremes. When the proportion is expressed in fractional form, you can obtain these equal products by cross-multiplying the terms of the proportion. For example:

$$\frac{2}{5} = \frac{6}{15}$$

$$2 \times 15 = 30 \text{ (product of the extremes)}$$

$$5 \times 6 = 30 \text{ (product of the means)}$$

Calculations for voltage divider circuits often involve proportions. For example, the following proportions can be written for the voltage and resistance of the resistor voltage divider in figure 2-2.

$$7.5:75 = 100:(100 + 900)$$

$$7.5:75 = 100:1000$$

To check this proportion, determine whether the product of the means equals the product of the extremes:

$$75 \times 100 = 7500 \text{ (product of means)}$$

$$7.5 \times 1000 = 7500 \text{ (product of extremes)}$$

The following proportion can be written for the voltage and capacitance of the capacitor voltage divider in figure 2-3.

$$\text{Output voltage: } 75 = 0.09:(0.01 + 0.09)$$

$$\text{Output voltage: } 75 = 0.09:0.1$$

To find the value of the output voltage, divide the product of the means by the second extreme:

$$\begin{aligned} \text{Output voltage} &= \frac{75 \times 0.09}{0.1} \\ &= 67.5 \text{ volts} \end{aligned}$$

Two numbers are *inversely proportional* when one will increase as the other is decreased so that their product remains constant. The two means of a proportion can be changed in an inverse manner while their extremes are held constant, and the two extremes can be changed in an inverse manner while their means are held constant. For example, in the proportion

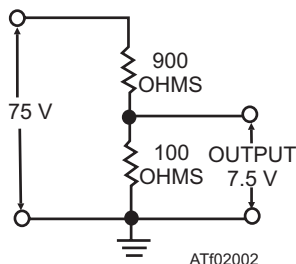

Figure 2-2.—Resistor voltage divider.

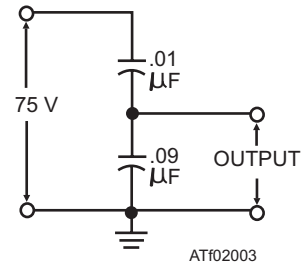

Figure 2-3.—Capacitor voltage divider.

2:5 = 8:20, the product of the means, 5 and 8, is 40. If the first mean is doubled and the second mean is halved, the proportion becomes 2:10 = 4:20. The product of the means remains 40 and the proportional relationship between the ratios remains the same. An inverse proportion between two quantities is illustrated by Ohm's law, which states that the current through a resistor is equal to the voltage across the resistor divided by the resistance. For example, when 12 volts is dropped across a 600-ohm resistor, the current can be found as follows:

$$\frac{12 \text{ volts}}{600 \text{ ohms}} = 0.02 \text{ ampere}$$

If the voltage is held constant and the resistance is doubled, the current is halved, as shown below.

$$\frac{12 \text{ volts}}{1200 \text{ ohms}} = 0.01 \text{ ampere}$$

If the voltage is held constant and the resistance is halved, the current is doubled, as shown below.

$$\frac{12 \text{ volts}}{300 \text{ ohms}} = 0.04 \text{ ampere}$$

Therefore, the current through the resistor is inversely proportional to the resistance.

## VARIATIONS

When two quantities are interdependent, changes in the value of one may have a predictable effect on the value of the other. The effect of changes among related quantities is called *variation*. The three types of variation, which occur frequently in the study of scientific phenomena, are *direct*, *inverse*, and *joint*.

### Direct Variation

An example of direct variation is found in the following statement: The perimeter (sum of the lengths of the sides) of a square increases if the length of a side increases. In everyday language, this statement might become: The longer the side, the bigger the square. In mathematical symbols, using  $p$  for perimeter and  $s$  for the length of the side, the relationship is stated  $p = 4s$ .

Since the number 4 is constant, any variations that occur are the results of changes in  $p$  and  $s$ . Any increase or decrease in the size of  $s$  results in a corresponding increase or decrease in the size of  $p$ . Thus,  $p$  varies in the same way (increasing or decreasing) as  $s$ . This explains the terminology that is frequently used:  $p$  varies directly as  $s$ . In general, if a quantity can be expressed in terms of a second quantity multiplied by a constant, it is said to vary directly as the second quantity. For example, if  $x$  and  $y$  are variables and  $k$  is a constant,  $x$  varies directly as  $y$ , if  $x = ky$ . Thus, as  $y$  increases,  $x$  increases, and as  $y$  decreases,  $x$  decreases. There is a direct effect on  $x$  caused by any change in  $y$ .

The relationship  $x = ky$  is equivalent to  $\frac{x}{y} = k$ . If one

quantity varies directly as a second quantity, the ratio of the first quantity to the second quantity is a constant. Thus, whatever the value of  $x$ , where it is divided by  $y$ , the result always will be the same value,  $k$ . A quantity that varies directly as another quantity is also said to be directly proportional to the second quantity. In  $x = ky$ , the coefficient of  $x$  is 1. The relationship  $x = ky$  can be written in proportion form as:

$$\frac{x}{k} = \frac{y}{1}$$

or

$$\frac{k}{x} = \frac{1}{y}$$

Notice that the variables,  $x$  and  $y$ , appear either in the numerators or in the denominators of the equal ratios. This implies that  $x$  and  $y$  are directly proportional. The constant,  $k$ , is the *constant of proportionality*.

Another form of direct variation occurs when a quantity varies as some power of another. For example, consider the formula for the area of a circle,  $A = \pi r^2$ .

Table 2-1 shows the values of  $r$  and the corresponding values of  $A$ .

Notice how  $A$  changes as a result of a change in  $r$ . When  $r$  changes from 1 to 2,  $A$  changes from  $\pi$  to 4 times  $\pi$  or  $2^2$  times  $\pi$ . Likewise when  $r$  changes from 3 to 4,  $A$  changes not as  $r$ , but as the square of  $r$ . In

general, one quantity varies as the power of another if it is equal to a constant times that quantity raised to the power. Thus, in an equation such as  $x = ky^n$ ,  $x$  varies directly as the  $n$ th power of  $y$ . As  $y$  increases,  $x$  increases, but more rapidly than  $y$ , and as  $y$  decreases,  $x$  decreases, but again more rapidly.

### Inverse Variation

A quantity varies *inversely* as another quantity if the product of the two quantities is a constant. For example, if  $x$  and  $y$  are variables and  $k$  is a constant, the fact that  $x$  varies inversely as  $y$  is expressed by  $xy = k$  or  $x = \frac{k}{y}$ .

If values are substituted for  $x$  and  $y$ , we see that as one increases, the other must decrease, and vice versa. Otherwise, their product will not equal the same constant each time.

If a quantity varies inversely as a second quantity, it is *inversely proportional* to the second quantity. In  $xy = k$ , the coefficient of  $k$  is 1. The equality  $xy = k$  can be written in the form  $\frac{x}{k} = \frac{1}{y}$  or  $\frac{k}{x} = \frac{y}{1}$ .

Notice that when one of the variables,  $x$  or  $y$ , occurs in the numerator of a ratio, the other variable occurs in the denominator of the second ratio. This implies that  $x$  and  $y$  are inversely proportional.

Inverse variation may be illustrated by means of the formula for the area of a rectangle. If  $A$  stands for area,  $L$  for length, and  $W$  for width, the expression for the area of a rectangle in terms of the length and width is  $A = LW$ .

Suppose that several rectangles, all having the same area but varying lengths and widths, are to be compared. Then  $LW = A$  has the same form as  $xy = k$ , where  $A$  and  $k$  are constants. Thus  $L$  is inversely proportional to  $W$ , and  $W$  is inversely proportional to  $L$ .

If the constant area is 12 square feet (sq ft), this relationship becomes  $LW = 12$ . If the length is 4 ft, the width is found as follows:  $W = \frac{12}{L} = \frac{12}{4} = 3 \text{ ft}$ .

**Table 2-1.—Relation Between Values of Radius and Area in a Circle**

When $r =$	1	2	3	4	5	7	9
Then $A =$	$\pi$	$4\pi$	$9\pi$	$16\pi$	$25\pi$	$49\pi$	$81\pi$

If the length increases to 6 ft, the width decreases as follows:  $W = \frac{12}{6} = 2 \text{ ft}$ .

If a constant area is 12, the width of a rectangle decreases from 3 to 2 as the length increases from 4 to 6. When two inversely proportional quantities vary, one decreases as the other increases.

### Joint Variation

A quantity varies jointly as two or more quantities if it equals a constant times their product. For example, if  $x$ ,  $y$ , and  $z$  are variables and  $k$  is a constant,  $x$  varies jointly as  $y$  and  $z$ , if  $x = kyz$ . Note that this is similar to direct variation, except that there are two variable factors and the constant in the one number. In direct variation, we have only one variable and the constant.

The equality  $x = kyz$  is equivalent to  $\frac{x}{yz} = k$ .

If a quantity varies jointly as two or more other quantities, the ratio of the first quantity to the product of the other quantities is a constant. The formula for the area of a rectangle is an example of joint variation. If  $A$  is allowed to vary, then  $A$  varies jointly as  $L$  and  $W$ .

When the formula is written for general use, it is not commonly expressed as  $A = kLW$ , although this is a mathematically correct form. Since the constant of proportionality in this case is 1, there is no practical need for expressing it.

Using the formula  $A = LW$ , we make the following observations: If  $L = 5$  and  $W = 3$ , then  $A = 3(5) = 15$ . If  $L = 5$  and  $W = 4$ , then  $A = 4(5) = 20$ , and so on. Changes in the area of a rectangle depend on changes in either the length or the width or both. The area varies jointly as the length and the width.

As a general example of joint variation, consider the expression  $a \propto bc$ , where  $\propto$  = varies as. Written as an equation, this becomes  $a = kbc$ . If the value of  $a$  is known for particular values of  $b$  and  $c$ , we can find the new value of  $a$  corresponding to changes in the values of  $b$  and  $c$ . For example, suppose that  $a = 12$  when  $b = 3$  and  $c = 2$ . What is the value of  $a$  when  $b = 4$  and  $c = 5$ ?

Rewriting the proportion,  $\frac{a}{bc} = k$ . Thus  $\frac{12}{(3)(2)} = k$  and

$$\frac{a}{(4)(5)} = k.$$

Since quantities equal to the same quantity are equal to each other, we can set up the following proportion:

$$\frac{a}{(4)(5)} = \frac{12}{(3)(2)}$$

$$a = 40$$

Q2-7. The ratio of 30 to 5 can be expressed as which of the following?

1.  $30 \cdot 5$
2.  $30:5$
3. Both 1 and 2
4.  $30 \sim 5$

Q2-8. When a ratio is expressed as a percentage, it is a comparison of that number to which of the following?

1. 1
2. 10
3. 100
4. 1000

Q2-9. Which of the following is the ratio of  $1\frac{7}{8}$  to 3 expressed as a fraction reduced to the lowest term?

1.  $\frac{5}{8}$
2.  $\frac{15}{24}$
3.  $\frac{24}{15}$
4.  $\frac{16}{15}$

Q2-10. Which of the following refers to the first and fourth terms of a proportion?

1. Means
2. Extremes
3. Ratios
4. Constants

Q2-11. The ratio of the speed of two aircraft is 2 to 5. If the slower aircraft has a speed of 300 knots, what is the speed of the faster aircraft?

1. 525 knots
2. 650 knots
3. 710 knots
4. 750 knots

Q2-12. In the formula  $A = S^2$ , if  $S$  is doubled, how is  $A$  affected?

1. Multiplied by 2
2. Divided by 2
3. Multiplied by 4
4. Divided by 4

Q2-13. In the formula  $W = \frac{A}{L}$ , what will be the effect with an increase in  $L$ ?

1.  $W$  will decrease
2.  $W$  will increase
3.  $A$  will decrease
4.  $A$  will increase

## SYSTEMS OF LINEAR EQUATIONS

**LEARNING OBJECTIVES:** Define terms associated with systems of linear equations. Solve systems of simultaneous linear equations.

*Linear equations*, which have two variables, are common, and their solution involves extending some of the procedures that have already been introduced.

## RECTANGULAR COORDINATES

An outstanding characteristic of equations in two variables is their ability to be graphically analyzed. The rectangular coordinate system is used in analyzing equations graphically. This system of vertical and horizontal lines, meeting each other at right angles and thus forming a rectangular grid, is often called the *Cartesian coordinate system*.

### Coordinate Axes

The rectangular coordinate system is developed on a framework of reference. On a piece of graph paper, two lines are drawn intersecting each other at right

angles, as in figure 2-4. The vertical line is usually labeled with the capital letter  $Y$  and called the  $Y$  axis. The horizontal line is usually labeled with the capital letter  $X$  and called the  $X$  axis. The point where the  $X$  and  $Y$  axes intersect is called the *origin* and is labeled with the letter  $O$ .

Above the origin, numbers measured along or parallel to the  $Y$  axis are positive; below the origin they are negative. To the right of the origin, numbers measured along or parallel to the  $X$  axis are positive; to the left, they are negative.

### Coordinates

A point anywhere on the graph may be located by two numbers, one showing the distance of the point from the  $Y$  axis, and the other showing the distance of the point from the  $X$  axis. Point  $P$  (fig. 2-4) is six units to the right of the  $Y$  axis and three units above the  $X$  axis. We call the numbers that indicate the position of a point *coordinates*. The number indicating the distance of the point measured horizontally from the origin is the  $X$  coordinate (6, in this example). The number indicating the distance of the point measured vertically from the origin (3, in this example) is the  $Y$  coordinate.

In describing the location of a point by means of rectangular coordinates, it is customary to place the coordinates within parentheses and separate them with a comma. The  $X$  coordinate is always written first. The

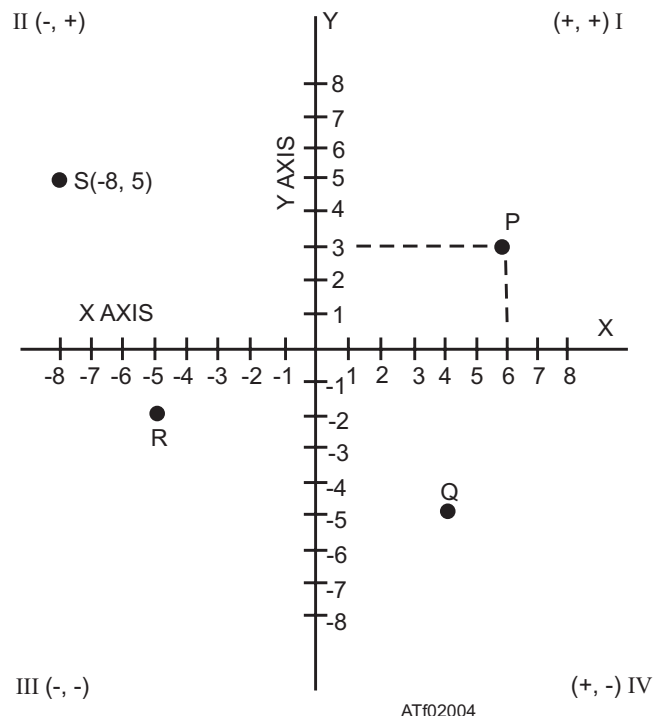

Figure 2-4.—Rectangular coordinate system.

Table 2-2.—Values of  $x$  and  $y$  in the Equation  $2x - y = 5$

If $x =$	-2	1	3	5	6	7	8
Then $y =$	-9	-3	1	5	7	9	11

coordinates of point P (fig. 2-4) are written (6,3). The coordinates for point Q are (4,-5); for point R, they are (-5,-2); and for point S, they are (-8,5).

Usually when we indicate a point on a graph, we write a letter and the coordinates of the point. Thus, in figure 2-4, for point S, we write S(-8,5). The other points would ordinarily be written P(6,3), Q(4,-5), and R(-5,-2). The Y coordinate of a point is often called its *ordinate* and the X coordinate is often called its *abscissa*.

### Quadrants

The X and Y axes divide the graph into four parts called *quadrants*. In figure 2-4, point P is in quadrant I, point S is in quadrant II, R is in quadrant III, and Q is in quadrant IV. In the first and fourth quadrants, the X coordinate is positive, because it is to the right of the origin. In the second and third quadrant, it is negative, because it is to the left of the origin. Likewise, the Y coordinate is positive in the first and second quadrants, being above the origin; it is negative in the third and fourth quadrants, being below the origin. Thus, we know in advance the signs of the coordinates of a point by knowing the quadrant in which the point appears. The signs of the coordinates in the four quadrants are shown in figure 2-4.

Locating points with respect to axes is called *plotting*. As shown with point P (fig. 2-4), plotting a point is equivalent to completing a rectangle that has segments of the axes as two of its sides with lines dropped perpendicularly to the axes forming the other two sides. This is the reason for the name *rectangular coordinates*.

### PLOTTING A LINEAR EQUATION

A linear equation in two variables may have many solutions. For example, in solving the equation  $2x - y = 5$ , we can find an unlimited number of values of  $x$  for which there will be a corresponding value of  $y$ . When  $x$  is 4,  $y$  is 3, since  $2(4) - 3 = 5$ . When  $x$  is 3,  $y$  is 1, and when  $x$  is 6,  $y$  is 7. When we graph an equation, these pairs of values are considered coordinates of points on the graph. The graph of an equation is nothing more than a line joining the points located by the various pairs of numbers that satisfy the equation.

To picture an equation, we first find several pairs of values that satisfy the equation. For example, for the equation  $2x - y = 5$ , we assign several values to  $x$  and solve for  $y$ . A convenient way to find values is to first solve the equation for either variable, as follows:

$$\begin{aligned} 2x - y &= 5 \\ -y &= -2x + 5 \\ y &= 2x - 5 \end{aligned}$$

Once this is accomplished, the value of  $y$  is readily apparent when values are substituted for  $x$ . The information derived may be recorded in a table such as table 2-2. We then lay off X and Y axes on graph paper, select some convenient unit distance for measurement along the axes, and then plot the pairs of values found for  $x$  and  $y$  as coordinates of points on the graph. Thus, we locate the pairs of values shown in table 2-2 on a graph, as shown in figure 2-5 view (A).

Finally, we draw a line joining these points, as in figure 2-5 view (B). As it is a straight line; it is called a *linear equation*. Once the graph is drawn, write the equation it represents along the line.

It can be shown that the graph of an equation is the geometric representation of all the points whose coordinates satisfy the conditions of the equation. The line represents an infinite number of pairs of coordinates for this equation. For example, selecting at random the point on the line where  $x$  is  $2\frac{1}{2}$  and  $y$  is 0 and substituting these values in the equation, we find that they satisfy it. Thus,  $2\left(2\frac{1}{2}\right) - 0 = 5$ .

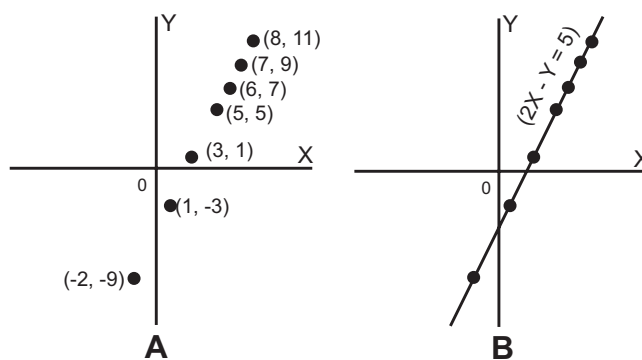

ATf02005

Figure 2-5.—Graph of  $2x - y = 5$ .

If two points that lie on a straight line can be located, the position of the line is known. The mathematical language for this is *two points determine a straight line*. We now know that the graph of a linear equation in two variables is a straight line. Since two points are sufficient to determine a straight line, a linear equation can be graphed by plotting two points and drawing a straight line through these points. Very often pairs of whole numbers, which satisfy the equation, can be found by inspection. Such points are easily plotted.

After the line is drawn through two points, plot a third point as a check. If this third point whose coordinates satisfy the equation lies on the line, the graph is accurately drawn.

### X and Y Intercepts

Any straight line, which is not parallel to one of the axes, has an X intercept and a Y intercept. These are the points at which the line crosses the X and Y axes. At the X intercept, the graph line is touching the X axis, and thus the Y value at that point is 0. At the Y intercept, the graph line is touching the Y axis; the X value at that point is 0.

In order to find the X intercept, we simply let  $y = 0$  and find the corresponding value of  $x$ . The Y intercept is found by letting  $x = 0$  and finding the corresponding value of  $y$ . For example, the line  $5x + 3y = 15$  crosses the Y axis at  $(0,5)$ . This may be verified by letting  $x = 0$  in the equation. The X intercept is  $(3,0)$ , since  $x$  is 3 when

$y$  is 0. Figure 2-6 shows the line  $5x + 3y = 15$  graphed by means of the X and Y intercepts.

### Solving Equations in Two Variables

A solution of a linear equation in two variables consists of a pair of numbers that satisfy the equation. For example,  $x = 2$  and  $y = 1$  constitute a solution of  $3x - 5y = 1$ . When 2 is substituted for  $x$  and 1 is substituted for  $y$ , we have  $3(2) - 5(1) = 1$ .

The numbers  $x = -3$  and  $y = -2$  also form a solution. This is true because substituting  $-3$  for  $x$  and  $-2$  for  $y$  reduces the equation to an identity:

$$\begin{aligned} 3(-3) - 5(-2) &= 1 \\ -9 + 10 &= 1 \end{aligned}$$

Each pair of numbers  $(x, y)$  such as  $(2, 1)$  or  $(-3, -2)$  locates a point on the line  $3x - 5y = 1$ . Many more solutions could be found. Any two numbers that constitute a solution of the equation are the coordinates of a point on the line represented by the equation.

Suppose we were asked to solve a problem such as finding two numbers with a sum of 33 and a difference of 5. We could indicate the problem algebraically by letting  $x$  represent one number and  $y$  the other. Thus, the problem may be indicated by the two equations

$$\begin{aligned} x + y &= 33 \\ x - y &= 5 \end{aligned}$$

Considered separately, each of these equations represents a straight line on a graph. There are many pairs of values for  $x$  and  $y$  which satisfy the first equation, and many other pairs which satisfy the second equation. Our problem is to find one pair of values that will satisfy both equations at the same time, or simultaneously. Hence, two equations for which we seek a common solution are called *simultaneous equations*. The two equations taken together comprise a *system* of equations.

**GRAPHICAL SOLUTION.**—If there is a pair of numbers that can be substituted for  $x$  and  $y$  in two different equations, the pair form the coordinates of a point that lies on the graph of each equation. The only way in which a point can lie on two lines simultaneously is for the point to be at the intersection of the lines. Therefore, the graphical solution of two simultaneous equations involves drawing their graphs and locating the point at which the graph lines intersect.

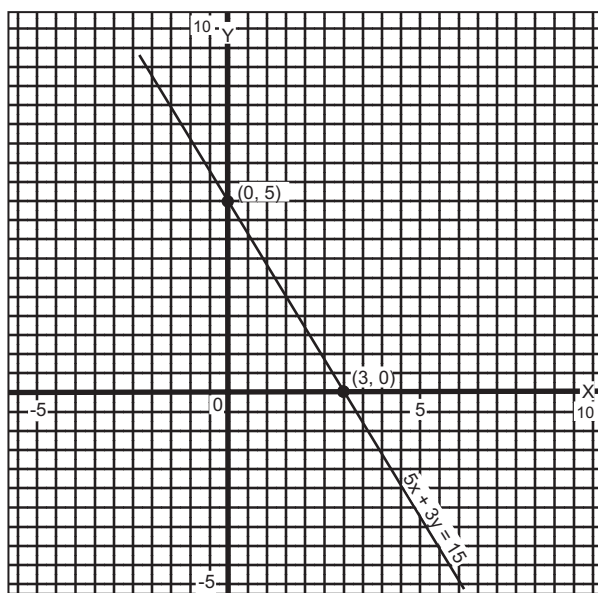

ATF02006

Figure 2-6.—Graph of  $5x + 3y = 15$ .

For example, when we graph the equations  $x + y = 33$  and  $x - y = 5$ , as in figure 2-7, we see that they intersect in a single point. There is one pair of values comprising coordinates of that point (19, 14), and that pair of values satisfies both equations, as follows:

$$\begin{array}{rcl} x + y & = & 33 \\ 19 + 14 & = & 33 \end{array} \qquad \begin{array}{rcl} x - y & = & 5 \\ 19 - 14 & = & 5 \end{array}$$

This pair of numbers satisfies each equation. It is the only pair of numbers that satisfies the two equations simultaneously.

Figure 2-8 shows the graphs of  $x + y = 11$  and  $x - y = -3$ . The intersection appears to be the point (4,7). Substituting  $x = 4$  and  $y = 7$  into the equations shows that this is the actual point of intersection, since this pair of numbers satisfies both equations.

The equations  $7x - 8y = 2$  and  $4x + 3y = 5$  are graphed in figure 2-9. The lines intersect where  $y$  is approximately  $\frac{1}{6}$  and  $x$  is approximately  $\frac{5}{6}$ .

**NOTE:** The graphic method of solving simultaneous equations is an approximate solution and the scale of the graph affects the approximation.

**ADDITION METHOD.**—The addition method of solving systems of equations is illustrated in the following example:

$$\begin{array}{r} x - y = 2 \\ +x + y = 8 \\ \hline 2x + 0 = 10 \\ x = 5 \end{array}$$

$$\begin{array}{r} x - y = 2 \\ (5) - y = 2 \\ -y = 2 - 5 \\ -y = -3 \\ y = 3 \end{array}$$

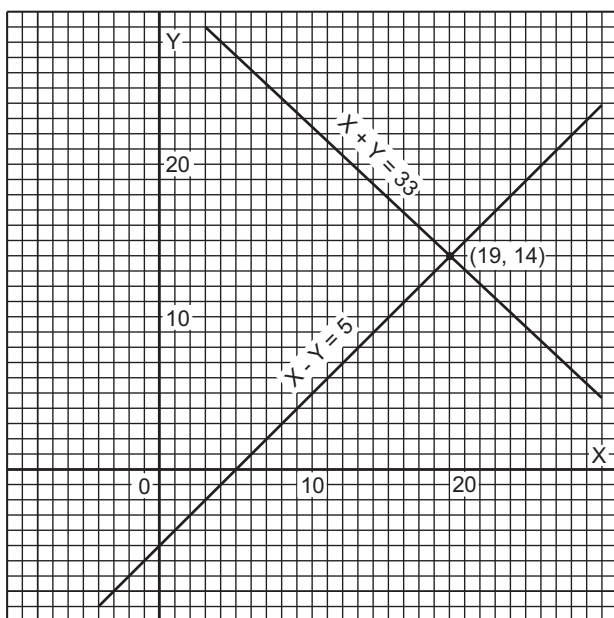

ATf02007

Figure 2-7.—Graph of  $x + y = 33$  and  $x - y = 5$ .

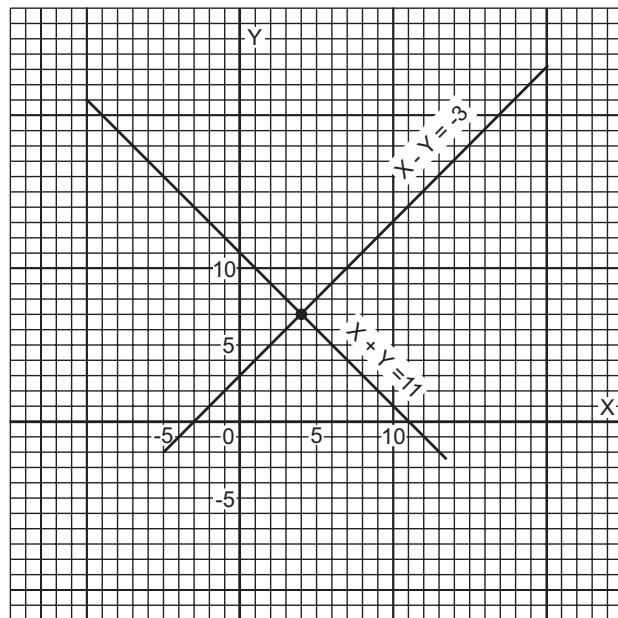

ATf02008

Figure 2-8.—Graph of  $x + y = 11$  and  $x - y = -3$ .

The result is obtained by adding the left member of the first equation to the left member of the second, and adding the right member of the first equation to the right member of the second. Having found the value of  $x$ , we substitute this value in either of the original equations to find the value of  $y$ , as follows:

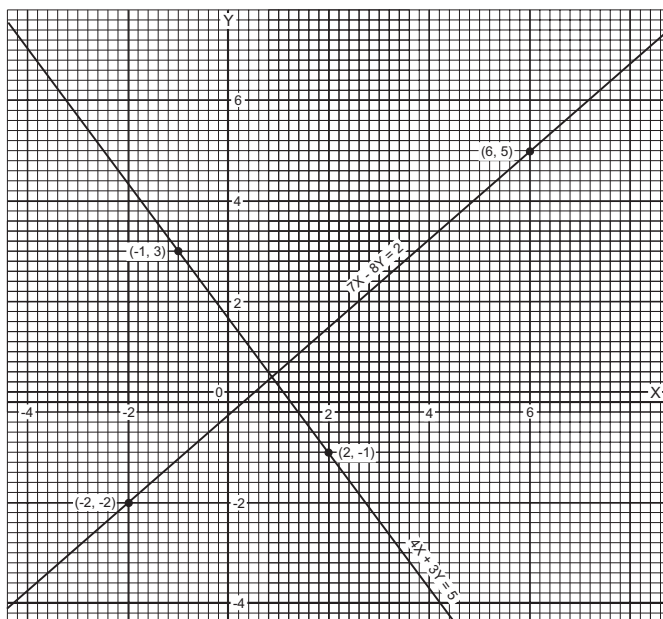

ATf02009

Figure 2-9.—Graph of  $7x - 8y = 2$  and  $4x + 3y = 5$ .



Notice the primary goal in the addition method is the elimination (temporarily) of one of the variables. If the coefficient of  $y$  is the same in both equations, except for its sign, adding the equations eliminates  $y$  as in the previous example. On the other hand, suppose that the coefficient of the variable that we desire to eliminate is exactly the same in both equations, as in the following example:

$$\begin{aligned}x + 2y &= 4 \\x + 3y &= -1\end{aligned}$$

Adding the equations would not eliminate either  $x$  or  $y$ . However, if we multiply both members of the second equation by  $-1$ , then addition will eliminate  $x$  as follows:

$$\begin{aligned}x + 2y &= 4 \\+ -x - 3y &= 1 \\ \hline -y &= 5 \\ y &= -5\end{aligned}$$

The value of  $x$  is found by substituting  $-5$  for  $y$  in either of the original equations, as follows:

$$\begin{aligned}x + 2(-5) &= 4 \\ x &= 14\end{aligned}$$

As a second example of the addition method, find the solution of the simultaneous equations

$$\begin{aligned}3x + 2y &= 12 \\ 4x + 5y &= 2\end{aligned}$$

Here both  $x$  and  $y$  have unlike coefficients. The coefficients of one of the variables must be made the same, except for their signs.

The coefficient of  $x$  will be the same except for signs if both members of the first equation are multiplied by 4 and both members of the second equation by  $-3$ , as follows:

$$\begin{aligned}12x + 8y &= 48 \\ + -12x - 15y &= -6 \\ \hline -7y &= 42 \\ y &= -6\end{aligned}$$

Substituting for  $y$  in the first equation to get the value of  $x$ , we have

$$\begin{aligned}3x + 2(-6) &= 12 \\ x + 2(-2) &= 4 \\ x - 4 &= 4 \\ x &= 8\end{aligned}$$

This solution is checked algebraically by substituting 8 for  $x$  and  $-6$  for  $y$  in each of the original equations, as follows:

$$\begin{aligned}3x + 2y &= 12 \\ 3(8) + 2(-6) &= 12 \\ 24 - 12 &= 12\end{aligned}$$

$$\begin{aligned}4x + 5y &= 2 \\ 4(8) + 5(-6) &= 2 \\ 32 - 30 &= 2\end{aligned}$$

**SUBSTITUTION METHOD.**—In some cases it is more convenient to use the substitution method of solving problems. In this method we solve one equation for one of the variables and substitute the value obtained into the other equation. This eliminates one of the variables, leaving an equation in one unknown. For example, find the solution of the following system:

$$\begin{aligned}4x + y &= 11 \\ x + 2y &= 8\end{aligned}$$

It is easy to solve for either  $y$  in the first equation or  $x$  in the second equation. Let us solve for  $y$  in the first equation. The result is  $y = 11 - 4x$ .

Since equals may be substituted for equals, we may substitute this value of  $y$  wherever  $y$  appears in the second equation. Thus,  $x + 2(11 - 4x) = 8$ . We now have one equation that is linear in  $x$ ; that is, the equation contains only the variable  $x$ .

Removing the parentheses and solving for  $x$ , we find that

$$\begin{aligned}x + 22 - 8x &= 8 \\ -7x &= 8 - 22 \\ -7x &= -14 \\ x &= 2\end{aligned}$$

To get the corresponding value of  $y$ , we must substitute  $x = 2$  in  $y = 11 - 4x$ . The result is

$$\begin{aligned}y &= 11 - 4(2) \\ y &= 11 - 8 \\ y &= 3\end{aligned}$$

Thus, the solution for the two original equations is  $x = 2$  and  $y = 3$ .

Q2-14. Which of the following is usually used to describe the vertical line in the rectangular coordinate system?

1. X axis
2. Y axis
3. Origin
4. X-Y intersect

Q2-15. Which of the following terms is used to describe the position of a point on a graph?

1. X-Y intercept
2. Quadrant
3. Variable
4. Coordinate

Q2-16. In the fourth quadrant of a graph, which of the following is true with respect to X and Y coordinates?

1. X is positive, Y is negative
2. X is positive, Y is positive
3. X is negative, Y is negative
4. X is negative, Y is positive

Q2-17. Which of the following is equal to the X intercept for the equation  $3x + 2y = 12$ ?

1. 2
2. 4
3. 6
4. 8

Q2-18. Which of the following is the simultaneous solution for the system of equations  $3x + 2y = 12$  and  $4x + 5y = 2$ ?

1.  $x = 0, y = 6$
2.  $x = 2, y = 3$
3.  $x = 8, y = -6$
4.  $x = 13, y = -10$

Q2-19. Which of the following is the simultaneous solution for the system of equations  $2x + 7y = 3$  and  $3x - 5y = 51$ ?

1.  $x = 5, y = -1$
2.  $x = -9, y = 3$
3.  $x = 17, y = 0$
4.  $x = 12, y = -3$

## CHAPTER 2

### ANSWERS TO REVIEW QUESTIONS

A2-1. *variable*

A2-2. *equation*

A2-3. *-10*

A2-4.  $x = a(b - c)$

A2-5. *Left member*

A2-6. *8 inches*

A2-7. *30:5*

A2-8. *100*

A2-9.  $\frac{5}{8}$

A2-10. *Extremes*

A2-11. *750 knots*

A2-12. *Multiplied by 4*

A2-13. *W will decrease*

A2-14. *Y axis*

A2-15. *Coordinate*

A2-16. *X is positive, Y is negative*

A2-17. *4*

A2-18.  $x = 8, y = -6$

A2-19.  $x = 12, y = -3$



## CHAPTER 3

# PHYSICS - BASICS

Physics is a basic branch of science and deals with matter, motion, force, and energy. It deals with the phenomena that arise because matter moves, exerts force, and possesses energy. Physics is closely associated with chemistry, and depends heavily upon mathematics for many of its theories and explanations. This chapter defines some of the physical terms and briefly discusses some of the particular principles that concern technical personnel, including measurement, structure and states of matter, and the mechanics of energy.

### MEASUREMENT

**LEARNING OBJECTIVES:** Identify units of measurement for distance (or length), mass, weight, and force. Identify derived units. Convert English to metric units and metric units to English units. Compute quantities by using derived units.

Measurement is an important consideration in science. To evaluate results, you must often answer the questions “how much, how far, how many, how often, or in what direction?” Measurements must be accurate, and new methods must be developed to measure new things. Measurements may be classed into three fundamental quantities—mass, distance (or length), and time. These are combined into several types of derived quantities, each with its own unit of measurement. Measurements of distance and time are well standardized and have few subdivisions. On the other hand, other measurement categories have many classes and subdivisions.

### SYSTEMS OF MEASUREMENT

The unit of measurement is as important as the number that precedes it. Both unit and its magnitude are necessary to give an accurate description. The two systems of measurement most commonly used are the metric and the English. Metric units are usually used to express scientific observations. One metric system uses the meter (m) as the basic unit of distance, the kilogram (kg) as the basic unit of mass, and the second (s) as the basic unit of time. This is called the *meter-kilogram-second (mks)* system. Another widely used

metric system uses the centimeter (cm) as the basic unit of distance, the gram (g) as the basic unit of mass, and the second as the basic unit of time, and is called the *centimeter-gram-second (cgs)* system. The English system uses the foot for distance, the pound avoirdupois (weight) for mass, and the second for time. This English system is called the *foot-pound-second (fps)* system. Refer to table 3-1 for frequently used units of measurement.

### UNITS OF DISTANCE OR LENGTH

Working with electricity and electronics requires the use of both the English and the metric systems of measurement. For example, radar range is usually expressed in the English system as yards or miles, but wavelength is most often expressed in the metric system with the meter as the basic unit.

#### Metric Units of Length

Metric units of length are based on the standard meter. When large distances are measured, use the kilometer (km), which is 1,000 meters (1 kilometer = 1,000 meters). For smaller measurements, the meter is divided into smaller units. One meter equals 100 centimeters (1 m = 100 cm), and 1 centimeter equals 10 millimeters (1 cm = 10 mm), so 1 meter equals 1,000 millimeters (1 m = 1,000 mm).

The micrometer ( $\mu\text{m}$ ) is smaller than the millimeter. The micrometer is one-thousandth of a millimeter or one-millionth of a meter; the nanometer (nm), often the unit used to state the wavelength of light, is one-thousandth of a micrometer; and the picometer (pm) is one-thousandth of a nanometer or one-millionth of a micrometer.

#### English Units of Length

The common units of distance in the English system of measurement are inches, feet, yards, and miles. One foot equals 12 inches (1 ft = 12 in.), 1 yard equals 3 feet (1 yd = 3 ft = 36 in.), and 1 mile equals 1,760 yards (1 mile = 1,760 yd = 5,280 ft = 63,360 in.). The nautical mile is 6,076.115 feet. The mil is one-thousandth of an inch.

Table 3-1.—Frequently Used Units of Measurement

ENGLISH SYSTEM	METRIC SYSTEM	GENERAL
acre	angstrom	<b>ELECTRICAL</b>
Btu (British thermal unit)	calorie	ampere
bushel	dyne	coulomb
dram	erg	decibel
foot	gram	farad
gallon	hectare	henry
hertz	hertz	mho (siemens)
horsepower	hour	ohm
hour	joule	volt
inch	liter	watt
knot	meter	<b>LIGHT</b>
mil	metric ton (1,000 kg)	candle
mile	micrometer	candela
minute	micron	lambert
ounce	minute	lumen
peck	newton	<b>MAGNETIC</b>
pint	quintal	gauss
pound	second	gilbert
quart	stere	maxwell
second		rel
slug		
ton (short, 2,000 lb) (long, 2,240 lb)		
yard		

In 1866 the United States, by an act of Congress, defined the yard to be  $\frac{3600}{3937}$  part of a standard meter, or in decimal form, approximately 0.9144 meter. Therefore, you can make conversions from yards to meters by multiplying the number of yards by 0.9144 meter; likewise, convert meters to yards by dividing the number of meters by 0.9144. Some approximate conversions are listed in table 3-2.

When a number is multiplied by a power of ten, the decimal point is moved the number of places

represented by the power. A negative power moves the decimal point to the left; a positive power moves the decimal point to the right. ( $84 \times 10^{-2} = .84$ , and  $84 \times 10^{+2} = 8,400$ ). Simply stated, a power of ten merely moves the decimal point to the left or right.

### VOLUME

Volume is the amount of space enclosed within the bounding surfaces of a body. To determine the volume of a regularly shaped body, you will need three measurements—length, width, and height (depth).

Table 3-2.—Conversion Factors for Units of Length

	km	m	cm	mm	in.	ft	yd	mile
1 km =	1	1,000	100,000	$1 \times 10^6$	39,370	3,280.83	1,093.61	0.621369
1 m =	0.001	1	100	1,000	39.37	3.28083	1.09361	$6.214 \times 10^{-4}$
1 cm =	$1 \times 10^{-5}$	0.01	1	10	0.3937	0.032808	$1.094 \times 10^{-2}$	$6.214 \times 10^{-6}$
1 mm =	$1 \times 10^{-6}$	$1 \times 10^{-3}$	0.1	1	0.03937	$3.28 \times 10^{-3}$	$1.094 \times 10^{-3}$	$6.214 \times 10^{-7}$
1 in. =	$2.54 \times 10^{-5}$	$2.54 \times 10^{-2}$	2.54	25.4	1	0.08333	0.02777	$1.58 \times 10^{-5}$
401 ft =	$3.048 \times 10^{-4}$	0.3048	30.48	304.8	12	1	0.3333	$1.89 \times 10^{-4}$
1 yd =	$9.144 \times 10^{-4}$	0.9144	91.44	914.4	36	3	1	$5.68 \times 10^{-4}$
1 mile =	1.60934	1,609.34	160,934	1,609,340	63,360	5,280	1,706	1

Volume = length  $\times$  width  $\times$  depth (height)

$$V = lwh$$

Volume measurement (fig. 3-1) is expressed as dimensions of length cubed because it is the product of three length measurements. The unit of volume is a cube having edges of unit length.

Ingenuity is often needed to measure the volume of irregularly shaped bodies. Sometimes it is practical to divide a body into a series of regularly shaped parts and then apply the rule that the total volume is equal to the sum of the volumes of all individual parts. Figure 3-2 shows another way to measure the volume of small irregular bodies. The volume of water displaced by a body submerged in water is equal to the volume of the body.

Measuring the volume of floating bodies can be done in a similar way. A floating body displaces its own weight of liquid. This may be proven by filling a container to the brim with liquid, then lowering the body to the surface of the liquid. Next, catch the liquid that flows over the brim. By weighing the displaced

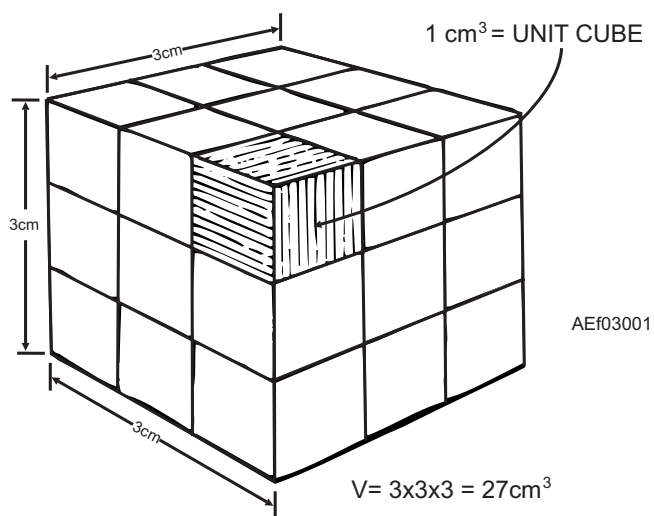

Figure 3-1.—Volume measurement.

liquid and the original body, you can prove the statement, “A floating body displaces its own weight of liquid.”

### UNITS OF MASS, WEIGHT, AND FORCE

The measure of the quantity of matter that a body contains is called *mass*. The mass of a body does not change. A body may be compressed to a smaller volume or expanded by heat, but the quantity of matter remains the same. While the mass of a body is constant no matter where the body is located, the body’s weight is slightly higher at the poles than at the equator, and becomes less as the body moves away from the earth’s surface. The weight of a body is the force with which the body is attracted toward the earth by gravity.

The metric unit of mass is the gram. In the English system, the standard pound (lb) is the unit of mass. The pound is equal to 0.4536 kilogram or 453.6 grams. To convert pounds to grams, multiply the pounds by 453.6, or to convert grams to pounds, divide the grams by 453.6. For example, 12 pounds equals 5443.2 g or 5.4 kg ( $12 \times 453.6$ ) and 6,804 grams equals 15 pounds ( $6804 \div 453.6$ ). These units describe the weight of a body by comparing the body’s weight to the weight of a standard mass unit. Normally, when an object is described as weighing 1 pound, it means the object has the same pull of gravity that a mass of 1 pound would have near the earth’s surface at sea level. At sea level,

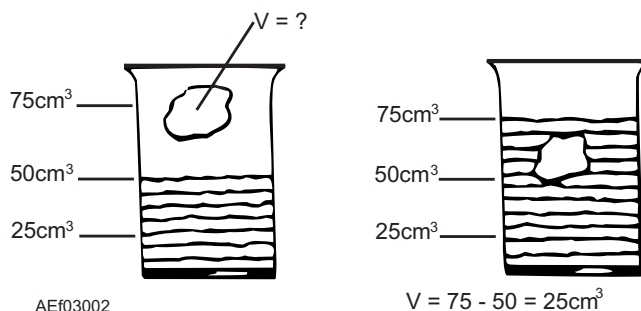

Figure 3-2.—Measuring the volume of an irregular object.

the numerical values of weight and mass of a given object are equal when weight and mass are expressed in the same units. Sometimes the slug is used as the unit of mass. This is the mass that weighs 32 pounds at sea level.

It's easy to convert between the weight units of the metric system since you only have to move the decimal point through a conversion of 1000:1. For example, 1,000 milligrams (mg) = 1.000 g, 1,000 g = 1.000 kg, and 1,000 kg = 1.000 metric ton. It's harder to convert between weight units of the English system since the pound is divided into 16 ounces and the ounce into 16 drams. The short ton is 2,000 pounds, while the long ton is 2,240 pounds. (The metric ton is fairly close to the long ton and is 2,205 pounds.)

At sea level, a mass of 1 gram exerts a downward force of 980 dynes because of gravity, and 1 kilogram exerts a downward force of 9.8 newtons. Since 1 kg = 1,000 g, a kilogram exerts a force of 1,000 × 980 dynes, or 980,000 dynes, which is equal to 9.8 newtons. Therefore, 1 newton equals 100,000 dynes.

The newton can be equated to the English system as follows: 1 newton equals a force of 0.2247 pound or a force of 1 pound equals 4.448 newtons.

## TIME

Time is a fundamental unit. The English and metric systems have the same units of measurement—hour, minute, and second.

## DERIVED UNITS

Derived units are based on combinations of two or three fundamental quantities. The watt (unit of power) can be written as 1 joule (unit of energy) per second. The joule could be expressed as 1 newton (force) times 1 meter (distance), and the watt then becomes 1 newton-meter per second. Likewise, the unit of horsepower could be expressed in foot-pounds per second. Although there are conversion factors between

derived units of the English system and the metric system, fundamental units of the two systems must not be combined. For example, if force is given in pounds and distance in meters, one or the other must be changed before they are combined to get work units.

## Speed

One example of a derived unit is the knot, a unit of speed. This unit combines the nautical mile as the unit of distance and the hour as the unit of time. Speed is the distance traveled divided by the time required for that travel. For example, if an aircraft traveled at a constant rate for 15 minutes (0.25 hr) and moved a distance of 110 nautical miles, its speed would be  $\frac{110}{0.25}$  or 440

knots. The rate of travel (speed) may also be used to solve for distance traveled when time is known. If the above aircraft traveled 440 knots for 3 hours, the aircraft would move 1,320 nautical miles (440 × 3 = 1,320 nautical miles). Likewise, the time required for moving a certain distance may be determined when the speed is known. A movement of 660 nautical miles by an aircraft traveling at 440 knots would require 1 hour and 30 minutes  $\left(\frac{660}{440} = 1.5 \text{ hr, or } 1 \text{ hr } 30 \text{ min}\right)$ .

Speed is often expressed as two fundamental units, such as miles per hour; kilometers per hour; or feet, inches, meters, or centimeters per minute or per second. Conversion is a matter of replacing one unit by its equivalent in another unit. For example, a speed of 60 miles per hour (60 mph) is converted to feet per second by replacing the mile with 5,280 feet and the hour with 3,600 seconds. Therefore, a speed of 60 mph =  $60 \left(\frac{5,280 \text{ ft}}{3,600 \text{ s}}\right) = 88 \text{ feet per second}$ .

Table 3-3 gives the conversion factors between meters per second (m/s), feet per second (ft/s), kilometers per hour (km/hr), miles per hour (mph), and knots.

**Table 3-3.—Conversion Factors for Speed and Velocity**

speed	m/s	ft/s	km/hr	mph	knots
1 m/s =	1	3.281	3.6	2.24	1.94
1 ft/s =	0.3048	1	1.0973	0.6818	0.5921
1 km/hr =	0.27778	0.9113	1	0.6214	0.5396
1 mph =	0.44704	1.4667	1.6093	1	0.8684
1 knot =	0.5148	1.689	1.853	1.152	1



## Velocity

The terms *speed* and *velocity* are sometimes interchanged. However, velocity is a vector quantity; that is, velocity is speed in a given direction. For example, a car may move around a circular path with a constant speed while its direction is continuously changing. When a body moves with constant speed along a straight line whose direction is specified, it is customary to speak of its velocity (which is numerically equal to its speed). When a body moves along a curved path or along a straight path with no reference being made to direction, it is proper to speak of its speed.

## Work

Units of work are derived units, and are the product of the units of force and distance. In the cgs system, the erg is the work done by a force of 1 dyne acting through a distance of 1 centimeter. The joule is the unit of work in the mks system, where 1 newton acts through a distance of 1 meter. Since 1 newton equals 100,000 dynes and 1 meter equals 100 centimeters, the joule is equal to 10 million ergs.

In the English system, the unit foot-pound is defined as the work done in lifting 1 pound a distance of 1 foot against the force of gravity. For example, the work done in lifting a mass of 5 pounds vertically 4 feet is 20 foot-pounds ( $5 \text{ lb} \times 4 \text{ ft} = 20 \text{ ft-lb}$ ). (Do not confuse this foot-pound with the one used to measure torque.) Since 1 pound of force equals 4.448 newtons, and 1 foot equals 0.3048 meter, 1 foot-pound is approximately 1.356 joules.

## Power

Power is the time rate of doing work. All units of power include measurements of force, distance, and time because power equals work (which is force times distance) divided by time. The watt is the unit of power frequently used with electrical units, and it is also the rate of doing 1 joule of work in 1 second. Therefore, if a force of 5 newtons acts through a distance of 12 meters in 3 seconds, the power required is 20 watts, or

$$P = \frac{5 \times 12}{3} = 20$$

If the same work were to be done in 2 seconds, 30 watts would be required.

Horsepower is a larger unit of power. One horsepower equals 550 foot-pounds per second or 746

watts; therefore, 1 foot-pound per second is  $\frac{746}{550}$  watts or about 1.356 watts.

## Other Derived Units

Magnitude measurement is complex. Consider a few examples of measurement dealing with magnitude: temperature, voltage, loudness, and brightness. Then consider measurements based on combinations of quantities: density (weight per unit volume), pressure (force per unit area), thermal expansion (increase in size per degree change in temperature), and so forth. Also, measurements combine categories. The flow of liquids is measured in volume per unit of time, speed in distance per unit of time, rotation in revolutions per unit of time (second, minute, etc.), and frequency in cycles per second (hertz).

The selection of the proper unit of measurement is important. Different systems of measurement can further complicate matters. For example, distance (or length) may be measured in feet or in meters; weight, in pounds or in kilograms; capacity, in quarts or in liters; temperature, in degrees of Fahrenheit, Celsius, Rankine, or in Kelvin units; density, in pounds per cubic foot or in grams per cubic centimeter; and angles, in degrees or in radians.

- Q3-1. *The three fundamental quantities of measurement are \_\_\_\_\_, distance (or length), and time.*
- Q3-2. *\_\_\_\_\_ units are usually used to express scientific observations.*
- Q3-3. *In the cgs system, the (a) \_\_\_\_\_ is the basic unit of distance, the (b) \_\_\_\_\_ is the basic unit of mass, and the second is the basic unit of time.*
- Q3-4. *Metric units of length are based on the standard \_\_\_\_\_.*
- Q3-5. *A3- kilometer is equal to \_\_\_\_\_ meters.*
- Q3-6. *To convert yards to meters, you must multiply the number of yards by \_\_\_\_\_.*
- Q3-7. *What is the equivalent of 7 meters expressed in yards?*
- Q3-8. *The measure of the quantity of matter that a body contains is called \_\_\_\_\_.*
- Q3-9. *\_\_\_\_\_ units are based on a combination of two or three fundamental measures of quantities.*

- Q3-10. The \_\_\_\_\_ is a unit of measurement that combines the nautical mile as the unit of distance and the hour as the unit of time.
- Q3-11. The work that is done by lifting 8 pounds a vertical distance of 5 feet is equal to \_\_\_\_\_ foot-pounds.
- Q3-12. All units of power include measurements of force, distance, and \_\_\_\_\_.

## MATTER AND ENERGY

**LEARNING OBJECTIVES:** Identify general physics laws as they apply to general properties of matter. Define mass, energy, density, specific gravity, pressure, total force, and kinetic energy.

Matter is defined as “anything that occupies space and has weight or mass.” In its natural state, matter is a solid, a liquid, or a gas. All matter is composed of small particles called molecules and atoms. Matter may be changed or combined by various methods—physical, chemical, or nuclear, but is always subject to the law of conservation of energy and matter. Matter has many properties; properties possessed by all forms of matter are general properties, including space, inertia, density, pressure, and kinetic energy, while those properties possessed only by certain classes of matter are special properties.

Energy is defined as the “capacity for doing work.” It is classified in many ways; but in this nonresident training course (NRTC), energy is classified as mechanical, chemical, radiant, heat, light, sound, electrical, or magnetic. Energy is constantly being exchanged from one object to another and from one form to another.

### LAW OF CONSERVATION OF MATTER AND ENERGY

Matter may be converted from one form to another with no change in the total amount of matter. Energy also may be changed in form with no resultant change in the total quantity of energy. This is the law of conservation of energy and matter and can be restated as follows:

Although the total amount of matter and energy remains constant, matter can be converted into energy or energy into matter.

The basic mathematical equation that shows the relationship between matter and energy is  $E = mc^2$ ,

where  $E$  represents energy,  $m$  represents mass, and  $c$  represents the velocity of light.

From this equation, you can see that the destruction of matter creates energy, and that the creation of matter requires expenditure of energy. You can also see that a given quantity of matter is the equivalent of some amount of energy. In common usage, it is usually stated that “matter possesses energy.”

## GENERAL PROPERTIES OF MATTER

All forms of matter possess certain properties. In the basic definition, matter occupies *space* and has *mass* (inertia). Those terms represent most, if not all, of the general properties of matter.

### Space

The amount of space occupied by, or enclosed within, the bounding surfaces of a body is called volume. In the study of physics, this concept is modified somewhat to be completely accurate. You know that matter is a solid, a liquid, or a gas, and each has its own special properties. Liquids and solids tend to retain their volume when physically moved from one container to another, while gases tend to assume the volume of the container.

All matter is composed of atoms and molecules. These particles are composed of still smaller particles separated from each other by empty space. This idea is used to explain two general properties of matter—impenetrability and porosity.

Two objects cannot occupy the same space at the same time; this is known as *the impenetrability of matter*. The actual space occupied by the individual subatomic particles cannot be occupied by any other matter. The impenetrability of matter may, at first glance, seem invalid when a cup of salt is poured into a cup of water, as the result is considerably less than two cups of salt water. However, matter has an additional general property called *porosity*, which explains this apparent loss of volume—the water simply occupies space between particles of salt. Porosity is present in all material, but to a wide range or degree. Generally, gases are extremely porous and liquids only slightly so; solids vary over a wide range, from the sponge to the steel ball.

### Density and Specific Gravity

The *density* of a substance is its weight per unit volume. In the English system, 1 cubic foot of water

weighs 62.4 pounds; the density of water is 62.4 pounds per cubic foot. In the metric system, the density of water is 1 gram per cubic centimeter.

The *specific gravity* of a substance is the ratio of the density of the substance to the density of water and is expressed by the equation

$$\text{specific gravity} = \frac{\text{weight of substance}}{\text{weight of equal volume of water}}$$

Since specific gravity is a ratio, it is not expressed in units of measurement. For example, if a substance has a specific gravity of 4, 1 cubic foot of the substance weighs 4 times as much as 1 cubic foot of water (62.4 lb  $\times$  4 = 249.6 lb). In metric units, if a substance has a specific gravity of 4, 1 cubic centimeter of the substance weighs 4 grams (1g  $\times$  4 = 4g). (Note that in the metric system of units, the specific gravity of a substance has the same numerical value as its density since 1 cubic centimeter of water weighs 1 gram.)

Specific gravity and density are independent of the size of a sample of material and depend only upon the type of material in the sample. See table 3-4 for typical values of specific gravity for various substances.

**Table 3-4.—Typical Values of Specific Gravity**

SUBSTANCE	SPECIFIC GRAVITY
Aluminum	2.70
Brass	8.60
Copper	8.90
Gold	19.30
Ice	0.93
Iron	7.80
Lead	11.30
Platinum	21.30
Silver	10.50
Steel	7.80
Mercury	13.60
Ethyl alcohol	0.81
Water	1.00

### Pressure and Total Force

Pressure and force, while related topics, are not the same thing. A weight of 10 pounds that rests on a table exerts a total force of 10 pounds. However, the shape of the weight determines the effect of the weight. If the weight consists of a thin sheet of steel that rests on a flat surface, the effect is quite different from the effect of

the same sheet of steel that rests on a sharp corner on a surface.

Pressure is the distribution of a force with respect to the area over which that force is distributed. Pressure is defined as the force per unit of area, or

$$\text{pressure} = \frac{\text{force}}{\text{area}}$$

A flat pan of water with a bottom area of 24 square inches and a total weight of 72 pounds exerts a total force of 72 pounds, or a pressure of  $\frac{72}{24}$  or 3 pounds per square inch, on a flat table. If the pan is balanced on a block with a surface area of 1 square inch, the pressure is  $\frac{72}{1}$  or 72 pounds per square inch.

This is why a sharp knife cuts more easily than a dull one. The smaller area concentrates the applied force (increases the pressure) and the knife penetrates more easily. For hydraulic applications, the relationship between pressure and force describes the basic principle of operation. In enclosed liquids under pressure, the pressure is equal at every point on the surfaces of the enclosing container. The total force on a given surface in hydraulic applications is dependent on the area of the surface.

### Kinetic Energy

Moving bodies possess energy and are capable of doing work. The energy of mass in motion is called *kinetic energy* and may be expressed by the equation

$$\text{kinetic energy} = mv^2$$

where *m* represents the mass of the body, and *v* represents the velocity of its motion.

When the moving body is stopped, the body loses its kinetic energy. The energy is not destroyed but is merely converted into other forms of energy, such as *heat* and *potential* energy. Remember: bodies at rest possess energy by virtue of their position.

Q3-13. Matter is defined as anything that occupies \_\_\_\_\_ and has mass.

Q3-14. \_\_\_\_\_ is defined as the capacity for doing work.

Q3-15. The statement: "Although the total amount of matter and energy remains constant, matter can be converted into energy or energy into matter" is known as the law of \_\_\_\_\_ of matter and energy.

- Q3-16. Two objects cannot occupy the same space at the same time; this is known as the \_\_\_\_\_ of matter.
- Q3-17. The \_\_\_\_\_ of a substance is the ratio of the density of the substance to the density of water.
- Q3-18. \_\_\_\_\_ is defined as the force per unit of area.
- Q3-19. The energy of mass in motion is called \_\_\_\_\_ energy.

## STRUCTURE OF MATTER

**LEARNING OBJECTIVES:** Identify the subatomic particles of an atom. Describe the characteristics of elements. Differentiate between compounds and mixtures.

All matter is composed of atoms, which are composed of smaller subatomic particles, the makeup of which determines elements and their characteristics, including the formation of compounds and mixtures.

### SUBATOMIC PARTICLES

The subatomic particles of major interest in elementary physics are the electron, the proton, and the neutron. Electrons, protons, and neutrons may be considered electrical in nature. The proton has a positive charge. The electron has a negative charge. The neutron is neutral (neither positive nor negative). The composition of matter follows a consistent pattern for all atoms; however, the detailed arrangement of subatomic particles is different for each distinct substance. The combination and the arrangement of the subatomic particles determine the distinguishing chemical and physical characteristics of a substance.

The protons and the neutrons of an atom are closely packed together in the atom's nucleus, and the electrons revolve around the nucleus (fig. 3-3). Atoms normally are electrically neutral; that is, atoms normally contain an equal number of electrons and protons. This condition is not present all the time. Atoms that contain an equal number of electrons and protons are called balanced atoms. Atoms with an excess (too many) or a deficiency (too few) of electrons are called negative ions and positive ions, respectively.

The proton and the neutron have approximately the same mass. A proton or a neutron is approximately 1,836 times the mass of an electron. Nearly all the mass of an atom is contained in its nucleus. Normally, change

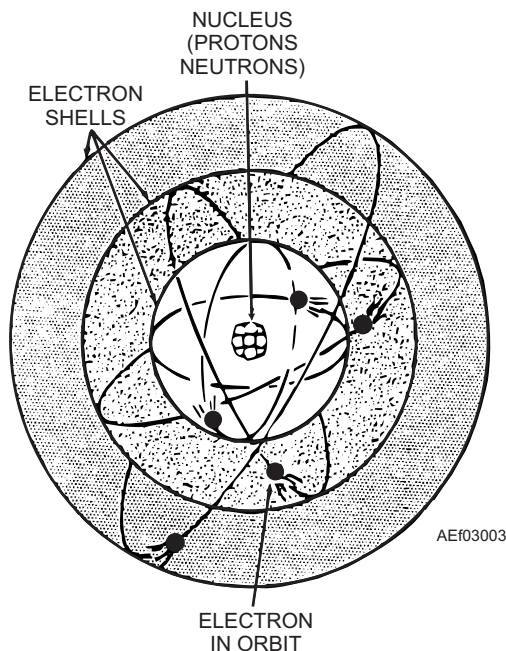

Figure 3-3.—An atom.

in the composition of the atom involves a change in the number or arrangement of the electrons (due to their smaller mass, electrons are more easily repositioned than protons). A notable exception is in the field of nuclear physics or nucleonics. In chemistry and in general physics (that includes electricity and electronics), the electron complement of an atom is the most important consideration.

### ELEMENTS

An element is one of about 100 substances that make up the basic substances of all matter. An atom is the smallest unit that exhibits the distinguishing characteristics of an element.

#### Protons and Atomic Number

Each atom of a given element contains the same number of protons in its nucleus. This number determines the type of matter. If the number of protons is changed, the atom has become an atom of a different element. The number of protons in the nucleus of the atom is referred to as the atomic number of the element.

#### Atomic Weight and Isotopes

If only the number of neutrons in the nucleus is changed, the atom remains an atom of the same element. Although all of the atoms of any particular element have the same number of protons (atomic

number), atoms of certain elements may contain various numbers of neutrons. Normally, an atom of hydrogen (the sole exception to the rule that all atoms are composed of three kinds of subatomic particles) contains a single proton and a single electron but no neutrons. However, some hydrogen atoms do contain a neutron. Such atoms are known as deuterium, or *heavy hydrogen*. (Deuterium is heavy because the addition of the neutron has approximately doubled the weight of the atom.) The atomic weight of an atom is an indication of the total number of protons and neutrons in the nucleus of the atom.

Atoms of the same element but with different atomic weights are called *isotopes*. Nearly all elements have several isotopes. Some isotopes are common, and some are rare. A few of the isotopes occur naturally. Isotopes produced by nuclear bombardment are radioactive or have unstable nuclei. These unstable isotopes undergo a spontaneous nuclear bombardment that eventually results in either a new element or a different isotope of the same element. The rate of spontaneous radioactive decay is measured by half-life. Half-life is the time required for one-half the atoms of radioactive material to change (by spontaneous radioactive decay) into a different substance. For example, uranium, after a few billion years and several substance changes, becomes lead.

### Electron Shells

The number and distribution of electrons in the atoms of an element determines the physical and chemical characteristics of the element. The electrons are in successive electron shells around the nucleus. Each shell can contain no more than a specific number of electrons. An *inert element* (one of the few gas elements that do not combine chemically with any other element) is a substance in which the outer electron shell of each atom is completely filled. In all other elements, one or more electrons are missing from the outer shell. An atom with only one or two electrons in its outer shell can be made to give up those electrons. An atom whose outer shell needs only one or two electrons to be completely filled can accept electrons from another element that has one or two extra electrons.

The concept of needed or extra electrons arises because an atom has a tendency to fill its outer shell. An atom whose outer shell has only two electrons may have to collect six additional ones (no easy task from an energy standpoint) to have the eight required for that shell to be full. The other alternative (easier from an

energy standpoint) is for the atom to give up the two electrons in the outer shell and allow the full shell next to it to serve as the new outer shell. In chemical terminology, this concept is called *valence*, which is the main factor that is used to predict the resulting chemical reactions.

## COMPOUNDS AND MIXTURES

Under certain conditions, two or more elements are brought together and united chemically to form a *compound*. The resulting substance may differ widely from its component elements. For example, the chemical union of two gases—hydrogen and oxygen—forms ordinary drinking water. When a compound is produced, two or more atoms of the combining elements join chemically to form a *molecule* that is typical of the compound. The molecule is the smallest unit that exhibits the distinguishing characteristics of a compound.

In the case of water, two atoms of hydrogen (each with a valence of +1) combine with a single atom of oxygen (valence of -2) to form a single molecule of water. Some of the more complex chemical compounds consist of many elements with various numbers of atoms of each. Molecules, like atoms, are normally electrically neutral. There are exceptions to this rule, such as the chemical activity in batteries.

The combination of sodium and chlorine to form the chemical compound sodium chloride (common table salt) is another example, as seen in figure 3-4. Sodium is a highly caustic, poisonous metal whose atom contains 11 electrons. Its outer shell consists of one electron (a valence of +1). Chlorine is a highly poisonous gas whose atom has 17 electrons, but chlorine lacks a single electron (a valence of -1) to fill its outer shell. When the atom of sodium gives up its outer electron, it becomes a positively charged ion. (It has lost a unit of negative charge.) The chlorine atom takes on this unit of negative charge (electron) to fill its outer shell and becomes a negative ion. Since opposite electric charges attract, the ions stick together to form

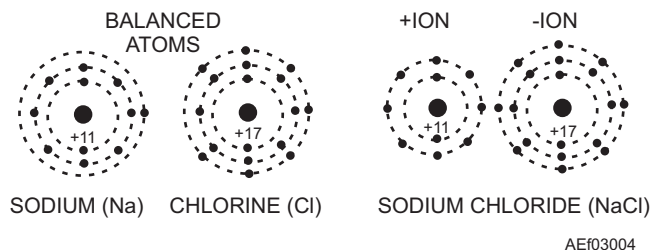

Figure 3-4.—Common table salt.

the crystalline substance we know as the compound sodium chloride.

**NOTE:** The attracting force that holds the ions together is known as the *valence bond*, a term that is frequently used in the study of transistors.

In the compound sodium chloride, there is no change in the nucleus of either atom; the only change is in the distribution of electrons between the outer shells of the atoms. Also, the total number of electrons has not changed, although there has been a slight redistribution with no resultant electrical charge.

Elements or compounds may be physically combined without undergoing any chemical change. Grains of finely powdered iron and sulfur that are stirred and shaken together retain their own identity as iron or sulfur. Salt dissolved in water does not become a compound; it is just salt dissolved in water. Each substance retains its chemical identity, even though the substance may undergo a physical change. This is the typical characteristic of a *mixture*. Substances in mixtures can be separated by physical means. A magnet can remove iron from sulfur and water can be boiled to leave salt.

- Q3-20. *The combination of \_\_\_\_\_ particles gives a substance its distinguishing characteristics.*
- Q3-21. *The three subatomic particles of the atom of interest in elementary physics are the electron, proton, and \_\_\_\_\_.*
- Q3-22. *A balanced atom is one that contains an equal number of electrons and \_\_\_\_\_.*
- Q3-23. *The atomic weight of an atom is an indication of the total number of protons and \_\_\_\_\_ in the atomic nucleus.*
- Q3-24. *When the outer electron shell of each atom of an element is completely filled it is referred to as a(n) \_\_\_\_\_ element.*
- Q3-25. *Two or more elements may combine chemically to form a(n) \_\_\_\_\_.*
- Q3-26. *The \_\_\_\_\_ is the smallest unit that exhibits the distinguishing characteristics of a compound.*
- Q3-27. *Elements or compounds physically combined without undergoing any chemical change are known as \_\_\_\_\_.*

## STATES OF MATTER

**LEARNING OBJECTIVE:** Identify the three natural states of matter, to include characteristics and laws associated with the different states of matter.

Matter can be classified according to its natural state—solid, liquid, or gas. This classification is important because of the common characteristics possessed by substances in one group that distinguish them from substances in the other groups. However, the usefulness of the classification is limited because most substances can assume any of the three forms.

The molecules of all matter are in constant motion; this motion determines the state of matter. The moving molecular particles in all matter possess kinetic energy of motion. The total of kinetic energy is equivalent to the quantity of heat in the substance. When heat is added, the energy level is increased, and molecular agitation (motion) is increased. When heat is removed, the energy level decreases, and molecular motion diminishes.

In solids, the molecular motion is restricted by the rigidity of the crystalline structure of the material. In liquids, molecular motion is somewhat less restricted, and the substance as a whole is permitted to flow. In gases, molecular motion is almost entirely random. The molecules of gas are free to move in any direction and collide with each other and the surfaces of the container.

### SOLIDS

A solid tends to retain its size and shape. Any change in size or shape requires the exchange of energy. The common properties of a solid are cohesion and adhesion, tensile strength, ductility, malleability, hardness, brittleness, and elasticity. *Ductility* is a measure of the ease with which the material can be drawn into a wire. *Malleability* refers to the ability of some materials to assume new shape when the metal is pounded. *Hardness* and *brittleness* are self-explanatory terms. The remaining properties are discussed in the following paragraphs.

#### Cohesion and Adhesion

Cohesion is the molecular attraction between like particles throughout a body or the force that holds any substance or body together. Adhesion is the molecular attraction that exists between surfaces of bodies in

contact or the force that causes unlike materials to stick together.

Different materials possess different degrees of cohesion and adhesion. In general, a solid body is highly cohesive but only slightly adhesive. Fluids (liquids and gases) are usually highly adhesive but only slightly cohesive. Generally, a material having one of these properties to a high degree will possess the other property to a relatively low degree.

### **Tensile Strength**

The cohesion between the molecules of a solid explains the property called tensile strength. This is a measure of the resistance of a solid to being pulled apart. Steel possesses this property to a high degree and is very useful in structural work. When a break does occur, the pieces of the solid cannot be stuck back together because pressing them together does not bring the molecules into close enough contact to restore the molecular force of cohesion. However, melting the edges of the break (welding) allows the molecules on both sides of the break to flow together. This brings them once again into the close contact required for cohesion.

### **Elasticity**

A substance that springs back to its original form after being deformed has the property of elasticity. This property is desirable in materials to be used as springs. Steel and bronze are examples of materials that exhibit elasticity.

All solids, liquids, and gases have elasticity of compression to some degree. The closeness of the molecules in solids and liquids makes them hard to compress, but gases are easily compressed because the molecules are farther apart.

## **LIQUIDS**

The outstanding characteristic of a liquid is its tendency to retain its own volume while assuming the shape of its container. A liquid is considered almost completely flexible and highly fluid.

Liquids are almost incompressible. Applied pressure is transmitted through them instantaneously, equally, and undiminished to all points on the enclosing surfaces. The hydraulic system is an example of liquids used in aircraft. The system is used to increase or decrease input forces to provide an action similar to that

of mechanical advantage in mechanical systems. The fluidity of the hydraulic liquid permits placement of the component parts of the system at widely separated points when necessary. A hydraulic power unit can transmit energy around corners and bends without the use of complicated gears and levers. The system operates with a minimum of slack and friction, which are often excessive in mechanical linkages. Uniform action is obtained without vibration, and the operation of the system remains largely unaffected by variations in load.

## **GASES**

The most notable characteristics of a gas are its tendency to assume not only the shape but also the volume of its container and the definite relationship that exists between the volume, pressure, and temperature of a confined gas.

The ability of a gas to assume the shape and volume of its container is the result of its extremely active molecular particles that move freely in any direction. Cohesion between gas molecules is extremely small, so the molecules tend to separate and distribute themselves uniformly throughout the volume of the container. In an unpressurized container of liquid, pressure is exerted on the bottom and the sides of the container up to the level of the liquid. In a container of gas, however, the pressure is also exerted against the top surface, and the pressure is equal at all points on the enclosing surfaces.

The relationship of the volume, pressure, and temperature of confined gas is explained by Boyle's law, Charles' law, and the general law for gases.

Many laboratory experiments based on these laws make use of the ideas of standard pressure and standard temperature. These are not natural standards, but are standard values selected for convenience in laboratory usage. Standard values are generally used at the beginning of an experiment or when a temperature or a pressure is to be held constant. Standard temperature is 0°C, the temperature at which pure ice melts. Standard pressure is the pressure exerted by a column of mercury 760 millimeters high. In many practical uses, these standards must be changed to other systems of measurement.

All calculations based on the laws of gases make use of absolute temperature and pressure. These topics require a somewhat more detailed explanation.

## Gas Pressure

Gas pressure is indicated in one of two ways—absolute pressure or gauge pressure. Since the pressure of an absolute vacuum is zero, any pressure measured with respect to this reference is referred to as *absolute pressure*.

At sea level the average atmospheric pressure is approximately 14.7 pounds per square inch (psi). This pressure would, in a mercurial barometer, support a column of mercury 760 millimeters in height. The actual pressure at sea level varies considerably. The pressure at any given altitude also differs from that at sea level. The atmospheric pressure must be taken into consideration when absolute pressure is converted to gauge pressure or vice versa.

When a pressure is expressed as the difference between its absolute value and that of the local atmospheric pressure, the measurement is designated *gauge pressure* and is usually expressed in *pounds per square inch gauge* (psig). Gauge pressure is converted to absolute pressure by adding the local atmospheric pressure to the gauge pressure.

### Absolute Zero

Absolute zero, one of the fundamental constants of physics, is usually expressed as  $-273^{\circ}$  centigrade (C) and is used in the kinetic theory of gases. According to kinetic theory, if the heat energy of a gas were progressively reduced, molecular motion would cease at some temperature. If accurately determined, this temperature could then be taken as a natural reference or a *true absolute zero value*.

Experiments with hydrogen indicate that if a gas were cooled to  $-273.16^{\circ}\text{C}$  (use  $-273^{\circ}\text{C}$  for most calculations), all molecular motion would cease and no additional heat could be extracted from the substance. At this point, both the volume and the pressure of gas would shrink to zero. When temperatures are measured with respect to the absolute zero reference, the temperatures are expressed in the absolute, or Kelvin (K), scale. Therefore, absolute zero may be expressed either as  $0^{\circ}\text{K}$  or as  $-273^{\circ}\text{C}$ .

### Boyle's Law

The Anglo-Irish scientist Robert Boyle discovered that when the temperature of an enclosed sample of gas was kept constant and the pressure was doubled, the volume was reduced to half the former value. Conversely, when the applied pressure was decreased, the volume was increased. He concluded that for a

constant temperature, the product of the volume and pressure of an enclosed gas remains constant. Boyle's law may be stated as follows:

Provided the temperature remains constant, the volume of a confined gas varies inversely with its pressure.

In equation form, this relationship may be expressed either

$$V_1P_1 = V_2P_2$$

or

$$\frac{V_1}{V_2} = \frac{P_2}{P_1}$$

where  $V_1$  and  $V_2$  refer to the original and final volumes, and  $P_1$  and  $P_2$  indicate the corresponding pressures.

### Charles' Law

The French scientist Jacques Charles provided the foundation for the modern kinetic theory of gases. He developed Charles' law that may be stated as follows:

A confined gas expands and contracts in direct proportion to the change in the absolute temperature provided the pressure is held constant.

In equation form, this part of the law may be expressed either

$$V_1T_2 = V_2T_1$$

or

$$\frac{V_1}{V_2} = \frac{T_1}{T_2}$$

where  $V_1$  and  $V_2$  refer to the original and final volumes, and  $T_1$  and  $T_2$  indicate the corresponding absolute temperatures.

A change in the temperature of a gas causes a corresponding change in volume. If a gas were heated while confined within a container with a fixed volume, the pressure would increase. In actual experiments, the increase in pressure was approximately  $\frac{1}{273}$  of the  $0^{\circ}\text{C}$

pressure for each  $1^{\circ}\text{C}$  increase. Because of this relationship, the normal practice is to state this relationship in terms of absolute temperature. In equation form, this part of the law becomes

$$P_1T_2 = P_2T_1$$

or

$$\frac{P_1}{P_2} = \frac{T_1}{T_2}$$



In words, this equation means that with a constant volume, the absolute pressure of a gas varies directly with the absolute temperature.

### General Gas Law

The facts about gases covered in the preceding sections are summed up and shown in figure 3-5. Boyle's law is shown in view A of the figure, while the effects of temperature changes on pressure and volume (Charles' law) are shown in views B and C, respectively.

Boyle's law and Charles' law can be combined into a single expression that encompasses both gas laws. This expression of the general gas law is as follows:

$$\frac{P_1 V_1}{T_1} = \frac{P_2 V_2}{T_2}$$

**NOTE:** The capital *P* and *T* signify *absolute pressure* and *temperature*, respectively.

Refer to figure 3-5 again. Here, you can see that the three equations (in views A, B, and C) are special cases of the general equation (in view D). If the temperature remains constant,  $T_1$  equals  $T_2$ , and both are eliminated from the general formula; the formula reduces to the form shown in view A. When the volume remains constant,  $V_1$  equals  $V_2$ , thereby reducing the general equation to the form given in view B. Similarly,  $P_1$  is equated to  $P_2$  for constant pressure, and the equation then takes the form given in view C.

The general gas law applies only when one of the three measurements remains constant. When a gas is compressed, the work of compression is done upon the gas. Work energy is converted to heat energy in the gas so that dynamic heating of the gas takes place. When air at 0°C is compressed in a nonconducting cylinder to half its original volume, its rise in temperature is 90°C, and when air is compressed to one-tenth, its rise is 429°C.

The general gas law applies with exactness only to ideal gases in which the molecules are assumed to be perfectly elastic. However, the general gas law describes the behavior of actual gases with sufficient accuracy for most practical purposes.

- Q3-28. The three natural states of matter are solid, liquid, or \_\_\_\_\_.
- Q3-29. A solid tends to retain its size and shape. Any change in size or shape requires the exchange of \_\_\_\_\_.
- Q3-30. \_\_\_\_\_ is the molecular attraction that exists between surfaces of bodies in contact, or the force that causes unlike materials to stick together.
- Q3-31. Tensile \_\_\_\_\_ is the measure of the resistance of a solid to being pulled apart.
- Q3-32. If a substance will spring back to its original form after it has been deformed, the substance has exhibited the property of \_\_\_\_\_.

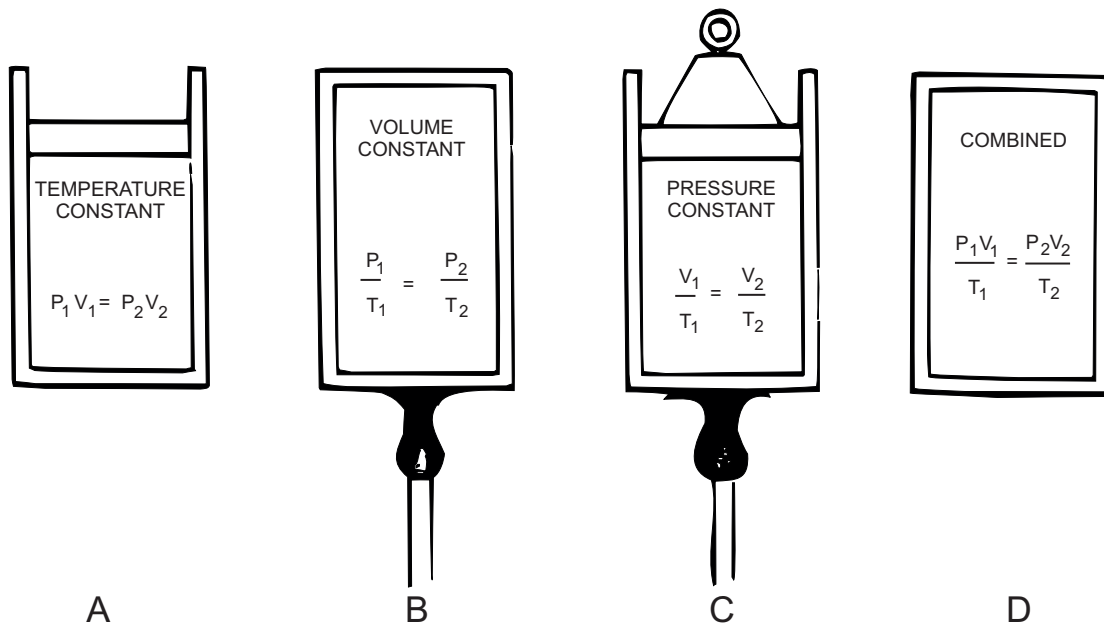

AEf03005

Figure 3-5.—Boyle's, Charles', and general gas laws.

- Q3-33. What state of matter has a characteristic of a tendency to retain its own volume while assuming the shape of its container?  
\_\_\_\_\_
- Q3-34. What force between gas molecules is extremely small, so the gas molecules tend to separate and distribute themselves uniformly throughout the volume of the container? \_\_\_\_\_
- Q3-35. Gas pressure is expressed in one of two ways, absolute pressure or \_\_\_\_\_ pressure.
- Q3-36. If a gas were cooled to  $-273^{\circ}\text{C}$  (absolute zero), all \_\_\_\_\_ motion would cease and no additional heat could be extracted from the substance.
- Q3-37. Boyle's law is normally stated: "The volume of a confined gas varies inversely with its \_\_\_\_\_ provided the temperature remains constant."
- Q3-38. \_\_\_\_\_ law states, "A confined gas expands and contracts in direct proportion to the change in the absolute temperature, provided the pressure is held constant."
- Q3-39. By combining Boyle's law and Charles' law, you can derive a single expression that states all the information that is contained in both laws. This expression is the \_\_\_\_\_ gas law.

## MECHANICS

**LEARNING OBJECTIVES:** Identify terms and recognize concepts involved with the mechanics of force, mass, and motion. Recognize the relationship between work, power and energy. Identify the difference between potential and kinetic energy, to include the effects of friction, efficiency, and mechanical advantage. Recognize the mechanics involved in revolving bodies and identify the forces that act on such bodies.

Mechanics is the branch of physics that deals with the ideas of force, mass, and motion. Many principles of mechanics and its ideas may be seen, measured, and tested, and the following discussion will include theories of gravity, work, power, energy, and revolving bodies.

## CENTER OF GRAVITY

Each particle in a body is acted upon by gravitational force. Every body has one point at which a single force equal to the gravitational force and directed upward would sustain the body in a condition of rest. This point is known as the center of gravity (cg). The cg is the point at which the entire mass of the body appears to be concentrated. The gravitational effect is measured from the center of gravity. In symmetrical objects of uniform mass, this is the geometrical center. In the case of the Earth, the center of gravity is near the center of the Earth.

When the motion of a body is considered, the path followed by the center of gravity is described. The natural tendency of a moving body is to move so that the center of gravity travels in a straight line. Movement of this type is *linear* motion. However, some moving bodies do not move in a straight line, but move in an arc or a circular path. *Circular* motion falls into two general classes—rotation and revolution.

The location of the center of gravity with respect to the body must be considered since objects come in many shapes and are subject to linear and circular motion. As you read the following section, refer to figure 3-6.

In view A, the center of gravity of a ball coincides with the physical center of the ball. In the flat washer (view B), the center of gravity does not coincide with any part of the object, but is located at the center of the hollow space inside the ring. In irregularly shaped bodies (view C), the center of gravity may be difficult to locate exactly.

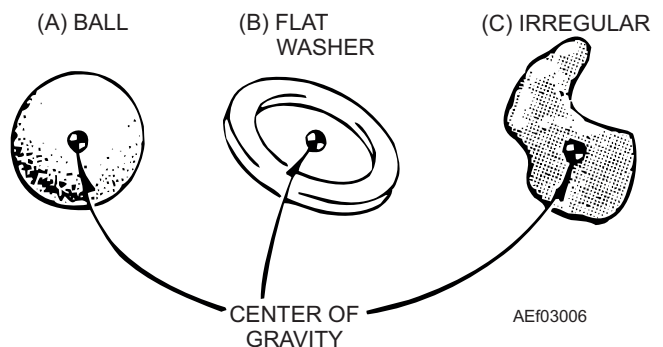

Figure 3-6.—Center of gravity in various bodies.

Look at figure 3-7. If the body is completely free to rotate, the center of rotation coincides with the center of gravity. However, the body may be restricted so that rotation is about some point other than the center of gravity. In this event, the center of gravity revolves around the center of rotation. The gyro rotor (view A) *rotates* about its axis, and the ball (view B) *revolves* about a point at the center of its path.

## MASSES IN MOTION

Motion is defined as the act or process of changing place or position. The state of motion refers to the amount and the type of motion possessed by a body at some definite instant (or during some interval of time). A body at rest is not changing in place or position. The body has zero motion, or is motionless.

The natural tendency of any body at rest is to remain at rest. A moving body tends to continue moving in a straight line with no change in speed or direction. A body that obeys this natural tendency is in uniform motion. Newton's three fundamental laws of motion explain these theories:

Every body tends to maintain a state of uniform motion unless a force is applied to change the speed or direction of motion.

The acceleration of a body is directly proportional to the magnitude of the applied force and inversely proportional to the mass of the body; acceleration is in the direction of the applied force.

For every force applied to a body, the body exerts an equal force in the opposite direction.

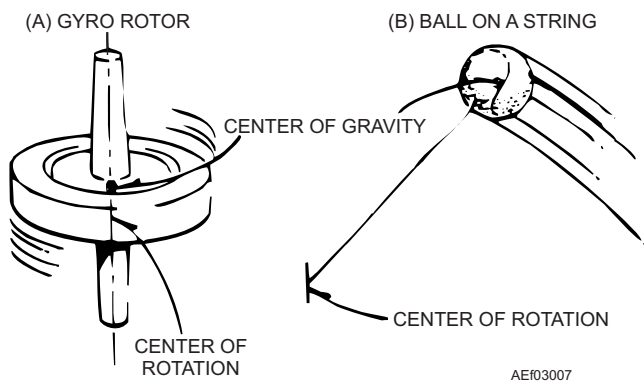

Figure 3-7.—Center of gravity and center of rotation.

Any change in the speed or direction of motion of a body is known as *acceleration* and requires the application of force. The acceleration of a body is directly proportional to the force causing that acceleration. Acceleration also depends upon the mass of the body. The greater mass of a lead ball makes the lead ball harder to move than a wood ball of the same diameter. A wood ball moves farther with the same push.

There is a relationship between force, mass, and acceleration. Acceleration of a body is directly proportional to the force exerted on that body and inversely proportional to the mass of that body. In mathematical form, the relationship between force ( $F$ ), mass ( $m$ ), and acceleration ( $a$ ) may be expressed as

$$a = \frac{F}{m}$$

or, as the relationship is more commonly stated, "Force is equal to the product of the mass and acceleration ( $F = ma$ )."

## FORCE

Force is the action on a body that tends to change the state of motion of the body acted upon. A force tends to move a body at rest, increase or decrease the speed of a moving body, or change the body's direction of motion. The application of a force to a body does not necessarily result in a change in the state of motion. The application of force may only tend to cause such a change.

A force is any push or pull that acts on a body. Water in a can exerts a force on the sides and bottom of the can. A tugboat exerts a push or a pull (force) on a barge. A person leaning against a bulkhead exerts a force on the bulkhead. In these examples, a physical object is exerting the force and is in direct contact with the body upon which the force is being exerted. Forces of this type are called *contact forces*.

Other forces act through empty space without contact and, at times, without seeming to have any mass associated with them. The force of gravity exerted on a body by the earth (weight) is an example of a force that acts on a body through empty space. Such a force is known as an *action-at-a-distance* force. Electric and magnetic forces are other examples of action-at-a-distance forces. The space through which these action-at-a-distance forces are effective is called a *force field*.

Force is a vector quantity; that is, force has both direction and magnitude. A force is completely described when its magnitude, direction, and point of application are given. In a force vector diagram, the starting point of the line represents the point of application of the force. A body may be subjected to many forces. These forces may be combined into a single resultant force on the body. When there is a difference in the masses of two bodies, the body with the larger mass exerts a resultant force on the body with the smaller mass. Because of the earth's extremely large mass, the earth exerts such a large gravitational attraction on other masses that it is practical to ignore all other attractions and use the earth's gravitational attraction as the resultant force. The earth's gravitational attraction is called *gravity*.

The gravitational force exerted by the earth on an object is the weight of the object and is expressed in force units. In the English system, force is expressed in pounds. If a gravitational force of 160 pounds attracts an object, the object weighs 160 pounds. The gravitational force between two objects decreases as the distance between them increases. An object weighs less a mile above the surface of the ocean than it weighs at sea level. An object also weighs more a mile below sea level than it weighs at sea level.

### Acceleration

A change in the state of motion of a body is known as acceleration. Acceleration is the rate of change in the motion of a body and may represent an increase or a decrease in the speed, a change in the direction of motion, or a change in the speed and the direction of motion.

The amount of acceleration is stated as the change of velocity divided by the time required to make the change. For example, if a car that is traveling 15 mph increased its speed to 45 mph in 4 seconds, the 30-mph increase divided by 4 seconds gives 7.5 miles per hour per second as its average acceleration. By converting the 30 mph to 44 feet per second, you could express the acceleration as 11 feet per second per second or as 11 ft/s<sup>2</sup>.

The lower case letter *g* represents the acceleration of a body in free fall, without friction. This can happen only in a vacuum. At sea level near the equator, *g* has the approximate values of 32 ft/s<sup>2</sup> in the fps system, 980 cm/s<sup>2</sup> in the cgs system, and 9.8 m/s<sup>2</sup> in the mks system. The absolute units of mass of a body may be

determined when its weight (*W*) is known. To solve for *m* in the formula  $W = mg$ , you transpose the formula so

$$m = \frac{W}{g}$$

When you use the formula stated in Newton's second law of motion (force equals mass times acceleration,  $F = ma$ ) to find what force is needed to give a 1-ton car an acceleration of 8 ft/s<sup>2</sup>,

substitute  $\frac{W}{g}$  for mass, so

$$\text{force} = \frac{2,000 \text{ lb}}{32 \text{ ft / s}^2} \times 8 \text{ ft/s}^2 = 500 \text{ pounds}$$

In the metric system, the *newton* is the force that causes a 1-kg mass to be accelerated 1 m/s<sup>2</sup>. Since  $g = 9.8 \text{ m/s}^2$ , a 1-kg mass exerts a force of 9.8 newtons due to gravity. A newton is equal to a force of 0.2247 lb.

The *dyne* is the force that causes a mass of 1 g to be accelerated 1 cm/s<sup>2</sup>. Therefore, a mass of 1 g exerts a force of 980 dynes due to gravity.

An accelerating force applied to the center of gravity to accelerate a body with no rotation is called a *translational force*. The force applied to cause a body to rotate about a point is called a *torque force*.

### Inertia

Every object in motion tends to maintain a uniform state of motion. A body at rest never starts to move by itself; a body in motion will maintain its speed and direction unless it is caused to change. To cause a body to change from its condition of uniform motion, a push or a pull must be exerted on the body. This requirement is due to that general property of all matter known as *inertia*. The greater the tendency of a body to maintain uniform motion, the greater its inertia. The quantitative (numerical) measure of inertia is the *mass* of a body.

### Momentum

Every moving body tends to maintain uniform motion. Quantitative measurement of this tendency is proportional to the mass and velocity of the body (momentum = mass × velocity). This explains why heavy objects in motion at a given speed are harder to stop than lighter objects. Momentum also explains why it is easier to stop a body that is moving at low speed than it is to stop the same body that is moving at high speed.

## WORK, POWER, AND ENERGY

As defined earlier, *energy* is the capacity for doing work. In mechanical physics, work involves the idea of a mass in motion. Work is the product of the applied force and the distance through which the mass is moved (work = force  $\times$  distance). For example, if a person raises a weight of 100 pounds to a height of 10 feet, he accomplishes 1,000 foot-pounds of work. The amount of work accomplished is the same regardless of the time involved. However, the rate of doing the work may vary.

The rate of doing work (called power) is defined as accomplished per unit of time (power = work/time). In the example cited above, if work is accomplished in 10 seconds, power is being expended at the rate of 100 foot-pounds per second. If work takes 5 minutes (300 seconds), the rate is approximately 3.3 foot-pounds per second.

$$\text{power} = \frac{\text{work}}{\text{time}} = \frac{1,000 \text{ foot-pounds}}{10 \text{ sec}} = \frac{100 \text{ foot-pounds}}{\text{sec}}$$

In the English system of measurements, the unit of mechanical power is called *horsepower*, and is the equivalent of 33,000 foot-pounds per minute or 550 foot-pounds per second. Since energy converts from one form to another, the work and power measurements based on the conversion of energy are readily convertible. For example, the electrical unit of power is the watt. Electrical energy can be converted into mechanical energy; therefore, electrical power can be converted into mechanical power. One horsepower is the mechanical equivalent of 746 watts of electrical power. One horsepower and 746 watts are capable of doing the same amount of work in the same time.

Doing work always involves a change in the type of energy, but does **not** change the total quantity of energy. Thus, energy applied to an object may produce work, changing the composition of the energy possessed by the object.

### Potential Energy

A body has *potential energy* if the body is able to do work. A wound clock spring and a cylinder of compressed gas both possess potential energy since the spring and cylinder can do work in returning to their unwound and uncompressed conditions. Also, a weight raised above the earth has potential energy since the weight can do work by returning to the ground. Potential energy results when work has been done against a restoring force. The water in a reservoir above

a hydroelectric plant has potential energy. This is true whether the water was placed in the reservoir by work applied via a pump or via the sun as rain from the water vapor cycle.

### Kinetic Energy

The ability of a body to do work through its motion is its *kinetic energy*. A rotating wheel on a machine has kinetic energy of rotation. A car moving along the highway has kinetic energy of translation.

For a given mass ( $m$ ) moving in a straight line with a velocity ( $v$ ), the kinetic energy is determined by

$$\text{kinetic energy} = \frac{1}{2}mv^2$$

**NOTE:** Kinetic energy is in ergs when  $m$  is in grams and  $v$  is in cm/s. Kinetic energy is in ft-lb when  $m$  is in slugs and  $v$  is in ft/s.

For example, the kinetic energy of a 3,200-lb car traveling at 30 miles per hour can be found by expressing the 3,200 lb as 100 slugs and the 30 mph as 44 feet per second. Inserting these values into the formula gives

$$\text{kinetic energy} = \frac{1}{2} \times 100 \times 44 \times 44 = 96,800 \text{ foot-pounds of energy}$$

This amount of kinetic energy is the result of applying 96,800 foot-pounds of work (plus that to overcome friction) to get the car to travel at the rate of 44 feet per second. The same amount of energy could do the work of lifting the 3,200 pounds vertically a distance of 30.25 feet. The energy also could have been from potential energy if the car had been at rest on an incline and then allowed to coast to a point which is vertically 30.25 feet below its starting point (again neglecting friction).

### Efficiency

If there is no change in the quantity of matter, energy is convertible with no gain or loss. However, the energy that results from a given action may not be in the desired form. The energy may not even be usable in its resultant form. In all branches of physics, this concept is known as *efficiency*.

Energy expended is always greater than energy recovered. An automobile in motion possesses a quantity of kinetic energy that depends on its mass and velocity. To stop the car, this energy is converted into potential energy. When the car stops, its potential energy is less than the kinetic energy it possessed while

in motion. The difference, or the *energy used*, was converted into heat by the brakes. The heat serves no useful purpose so the recovered energy is less than the expended energy. This means that the system is less than 100 percent efficient in converting kinetic to potential energy.

Normally, the term *efficiency* is used in connection with work and power considerations to show the ratio of the input to the output work, power, or energy. Efficiency is always expressed as a decimal or as a percentage less than unity.

### Friction

In mechanical physics, the most common cause for the loss of efficiency is *friction*. Whenever one object is slid or rolled over another, irregularities in the contacting surfaces interlock and cause an opposition to the force being exerted. Even rubbing two smooth pieces of ice together produces friction. Friction also exists in the contact of air with all exposed parts of an aircraft in flight.

When a nail is struck with a hammer, the energy of the hammer is transferred to the nail, and the nail is driven into a board. The depth of penetration depends on the momentum of the hammer, the size and shape of the nail, and the hardness of the wood. The larger or fuller the nail and the harder the wood, the greater the friction. This results in lower efficiency and a lesser depth of penetration but with a greater heating of the nail than if the nail had been slender and the wood softer.

In practice, friction is always present in moving machinery. This is why the useful work done by the machine is never as great as the energy applied. Work accomplished in overcoming friction is usually not recoverable. Friction is minimized by decreasing the number of contacting points, by making the contacting areas as small and as smooth as possible, by the use of bearings, or by the use of lubricants.

There are two kinds of friction—sliding and rolling. Rolling friction is usually of lower magnitude than sliding friction. Because of this, most machines are built so rolling friction is present rather than sliding friction. The ball bearing and the roller bearing are used to replace sliding friction with rolling friction. The common (or friction) bearings use lubricants applied to surfaces that decrease friction. Many machines use self-lubricating bearings to minimize friction and maximize efficiency.

### Mechanical Advantage

Mechanical advantage permits an increase in applied force through the use of levers, block-and-tackle systems, screws, hydraulic mechanisms, and other work-saving devices. Actually, these devices do not save work; the devices just let people do tasks that would otherwise be beyond their capability. For example, a person alone can't lift the rear end of a truck to change a tire, but the person can do the job with a jack.

Mechanical advantage is usually considered with respect to work. Work represents the application of a force through a distance to move an object through a distance. Therefore, you can see that two forces are involved, each with an appropriate distance. The simple lever (fig. 3-8) shows this.

If there is perfect efficiency, the work input ( $F_1 D_1$ ) is equal to the work output ( $F_2 D_2$ ). If distances  $D_1$  and  $D_2$  are equal, a force of 10 pounds must be applied at the source to counteract a weight of 10 pounds at the load.

When the fulcrum is moved nearer the load, less force is required to balance the same load. This is a *mechanical advantage* of force. If the force is applied to raise the load 1 foot, the source must be moved through a distance greater than 1 foot. Therefore, the mechanical advantage of force represents a mechanical disadvantage of distance. When the fulcrum is moved nearer the source, these conditions are reversed.

Since the input work equals the output work (assuming no losses), the mechanical advantage may be stated as a ratio of the force or of the distances. In practice, friction causes energy loss and decreased

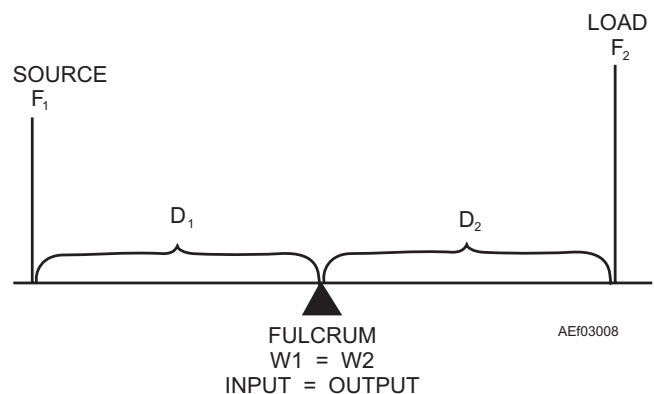

Figure 3-8.—Mechanical advantage.

efficiency, and it requires a greater input to do the same work.

## REVOLVING BODIES

Revolving bodies represent masses in motion; so they possess all the characteristics (and obey all the laws) associated with moving bodies. Revolving bodies possess a specific type of motion and have special properties and factors.

As bodies that travel in a constantly changing direction, revolving bodies are constantly subjected to an accelerating force. Momentum tends to produce linear motion, but this is prevented by application of a force that restrains the object. The force that prevents the object from continuing in a straight line is known as *centripetal force*. According to Newton's third law of motion, the centripetal force is opposed by an equal force that tends to produce linear motion. This second force is known as *centrifugal force*. The two forces, their relationships, and their effects are shown in figure 3-9.

The forces involved in revolving bodies may be demonstrated by using a ball and string. Tie a slip knot in the center of a 10-foot length of string to shorten the line to 5 feet. Then, attach a rubber ball to one end of the string. Holding the other end of the string, whirl the ball slowly in a circle. At this point in the experiment, you can tell that the ball exerts a force against your hand (through the string). As you keep the ball in its circular

path, your hand exerts a force (through the string) on the ball. As you revolve the ball at a higher speed, the forces increase, but the ball continues in a circular path.

At some rotational speed, the forces are enough to overcome inertial friction, and the knot slips. At this time, stabilize the velocity of rotation (keep the rotational velocity constant). Let's analyze what has happened. When the knot slips, the ball is temporarily unrestrained and is free to assume linear motion in the direction of travel at that instant (tangent to the circle at the instantaneous position, shown in fig. 3-9). The ball travels in a straight line until the string reaches its full length. During this time, no force is exerted by the hand. As soon as all the slack is taken up, there is a sharp jerk and an accelerating force is exerted to change the direction of motion from its linear path into a circular rotation. The ball again assumes rotational motion but with an increase in radius.

The ball does not make as many revolutions in the same time (rotational velocity is decreased), but the ball does maintain its former linear velocity. (The kinetic energy and the momentum of the ball have not changed.) Since the change in direction is less abrupt with a large radius than with a small one, less accelerating force is required, and the hand will feel less force. Now accelerate the ball to the same rotational velocity it had just before the knot slipped. The linear velocity of the ball becomes much greater than before. The centripetal and centrifugal forces are much greater also.

In this experiment, your hand is fixed at a point that represents the center of rotation. This assumption, while not exactly correct, does not affect the general conclusions you can draw from the experiment. For practical purposes, the two forces are equal at all points along the string at any given time, and the magnitude of each force is equal at all points along the string.

The above example and explanation can be summarized by the following mathematical relationship:

$$\text{force} = \frac{\text{mass} \times \text{velocity}^2}{\text{radius}}$$

where velocity represents the linear velocity of the ball.

This relationship describes the following facts about forces acting on revolving bodies:

- The centripetal and the centrifugal forces are equal in magnitude and opposite in direction.

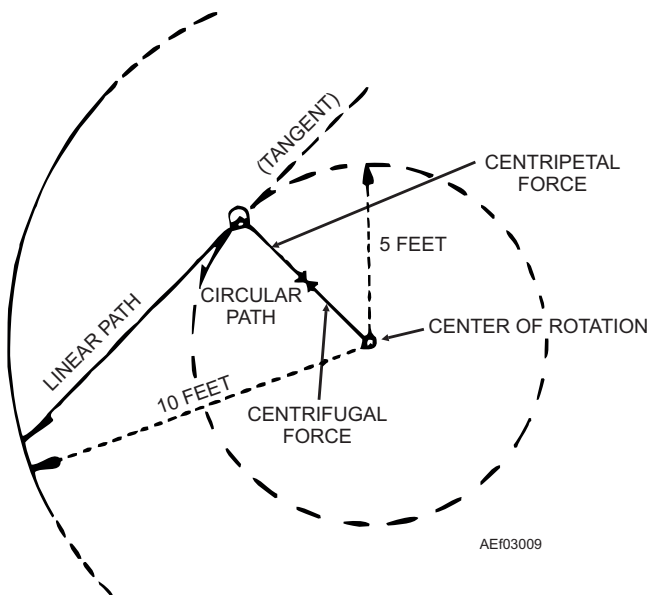

Figure 3-9.—Forces on revolving bodies.

- Each force is directly proportional to the mass of the body and inversely proportional to the radius of rotation.
- Each force is also proportional to the square of the velocity.

In revolving or rotating bodies, all particles of matter not on the axis of rotation are subjected to the forces just described. The statement is true whether the motion is through a complete circle or around a curve. An aircraft tends to skid when changing course, and an automobile tends to take curves on two wheels. The sharper the curve (smaller radius) or the higher the velocity, the greater the tendency to skid.

- Q3-40. *Mechanics is the branch of physics that deals with force, mass, and \_\_\_\_\_.*
- Q3-41. *The natural tendency of a moving body is to move so that the center of gravity travels in a straight line. Movement of this type is called \_\_\_\_\_ motion.*
- Q3-42. *Circular motion falls into two general classes: rotation and \_\_\_\_\_.*
- Q3-43. *Generally, a gyro rotor \_\_\_\_\_ about its axis.*
- Q3-44. *Every body tends to maintain a state of uniform motion unless a force is applied to change the speed or \_\_\_\_\_ of motion.*
- Q3-45. *Change in the speed or direction of motion of a body is known as acceleration and requires the application of \_\_\_\_\_.*
- Q3-46. *\_\_\_\_\_ is the action or effect on a body that tends to change the state of motion of the body acted upon.*
- Q3-47. *Any change in the state of motion of a body is known as \_\_\_\_\_.*
- Q3-48. *An accelerating force applied to the center of gravity to accelerate a body with no rotation is called a(n) \_\_\_\_\_ force.*
- Q3-49. *The quantitative measure of inertia is the \_\_\_\_\_ of the body.*
- Q3-50. *Momentum equals mass times \_\_\_\_\_.*
- Q3-51. *\_\_\_\_\_ is the rate of work accomplished per unit of time.*
- Q3-52. *If a body is able to do work, the body has \_\_\_\_\_ energy.*
- Q3-53. *The ability of a body to do work through its motion is its \_\_\_\_\_ energy.*
- Q3-54. *The ratio of the input to the output of work, power, or energy is described by what term? \_\_\_\_\_*
- Q3-55. *What is the most common cause for the loss of efficiency in a mechanical device? \_\_\_\_\_*
- Q3-56. *When a person uses a block and tackle to lift an engine from an automobile chassis, he or she is using \_\_\_\_\_ advantage to do work.*
- Q3-57. *The force that prevents a revolving object from continuing in a straight line is known as (a) \_\_\_\_\_ force, and this force is opposed by an equal force that tends to produce linear motion known as (b) \_\_\_\_\_ force.*



## CHAPTER 3

# ANSWERS TO REVIEW QUESTIONS

- A3-1. *Mass*  
A3-2. *Metric*  
A3-3. *(a) Centimeter; (b) gram*  
A3-4. *Meter*  
A3-5. *1,000*  
A3-6. *.9144*  
A3-7. *7.65 yards*  
A3-8. *Mass*  
A3-9. *Derived*  
A3-10. *Knot*  
A3-11. *40*  
A3-12. *Time*  
A3-13. *Space*  
A3-14. *Energy*  
A3-15. *Conservation*  
A3-16. *Impenetrability*  
A3-17. *Specific gravity*  
A3-18. *Pressure*  
A3-19. *Kinetic*  
A3-20. *Subatomic*  
A3-21. *Neutron*  
A3-22. *Protons*  
A3-23. *Neutrons*  
A3-24. *Inert*  
A3-25. *Compound*  
A3-26. *Molecule*  
A3-27. *Mixtures*  
A3-28. *Gas*  
A3-29. *Energy*  
A3-30. *Adhesion*  
A3-31. *Strength*  
A3-32. *Elasticity*  
A3-33. *Liquid*  
A3-34. *Cohesion*  
A3-35. *Gauge*  
A3-36. *Molecular*  
A3-37. *Pressure*  
A3-38. *Charles'*  
A3-39. *General*  
A3-40. *Motion*  
A3-41. *Linear*  
A3-42. *Revolution*  
A3-43. *Rotates*  
A3-44. *Direction*  
A3-45. *Force*  
A3-46. *Force*  
A3-47. *Acceleration*  
A3-48. *Translational*  
A3-49. *Mass*  
A3-50. *Velocity*  
A3-51. *Power*  
A3-52. *Potential*  
A3-53. *Kinetic energy*  
A3-54. *Efficiency*  
A3-55. *Friction*  
A3-56. *Mechanical*  
A3-57. *(a) Centripetal, (b) centrifugal*



## CHAPTER 4

# PHYSICS - APPLICATIONS

As a Navy Avionics Technician, you deal with complex equipment. You are expected to understand, operate, service, and maintain this equipment and to instruct new personnel. No matter how complex an item of equipment, its action is based on the application of a few basic principles of physics, such as heat, wave parameters, light, and sound. To understand, maintain, and repair the equipment necessary to operate Navy aircraft, you must understand these basic principles.

### HEAT

**LEARNING OBJECTIVES:** Recognize the methods of heat transfer. Understand equations used to convert between Fahrenheit and Celsius temperature scales. Recognize the principles and practical application of thermal expansion. Recognize the relationship between the Kelvin and Celsius temperature scales and the relationship between the Rankine and Fahrenheit temperature scales. Identify the purpose and use of various types of thermometers. Recognize the means of heat measurement in terms of mechanical equivalent and specific heat. Identify the role heat plays in changing the states of matter, to include fusion and vaporization.

Heat is thermal energy that is absorbed, given up, or transferred from one body to another. The temperature of a body is a measure of its ability to give up heat to, or absorb heat from, another body. Thus, the temperature of a body determines whether or not heat will be transferred to or from a nearby body. Since thermal energy also is defined as a form of energy, you may wonder why two different terms, *thermal energy* and *heat*, are used. An example will illustrate the difference. The temperature of the air in an aircraft tire will rise when the tire is being pumped up. It also will rise when the tire is left out on the runway in the sun. In both cases the thermal energy and the temperature of the air are increased. In the first case, the work done in pumping was converted to thermal energy. In the second case, the rise in temperature was due to energy being transferred from the sun to the tire. The term heat is used when the transfer of thermal energy from one

body to another body at a different temperature is involved.

Some of the characteristics heat possesses are important to the technician, including methods of transfer, temperature and measurement, and change of state. Knowledge of the nature and behavior of heat will help you understand the operation—and faulty or nonoperation—of some types of electronics equipment.

### NATURE OF HEAT

There are several theories about the nature of heat. The two theories most commonly discussed are the kinetic theory and the radiant energy theory.

The *kinetic theory* assumes that the quantity of heat contained in a body is represented by the total kinetic energy possessed by the molecules of the body.

The *radiation theory* treats radio waves, heat, and light as the same general form of energy, differing primarily in frequency. Heat is considered a form of electromagnetic energy involving a specific band of frequencies falling between the radio wave and light wave portions of the electromagnetic spectrum.

A common method of producing heat energy is the burning process. Burning is a chemical process in which fuel unites with oxygen and usually produces a flame. The amount of heat liberated per unit mass or per unit volume during complete burning is known as the heat of combustion of a substance. Each fuel produces a given amount of heat per unit of quantity burned.

### TRANSFER OF HEAT

There are three methods of heat transfer—conduction, convection, and radiation. In addition to these, a phenomenon called absorption is related to the radiation method.

#### Conduction

The metal handle of a hot pot will burn your hand while a plastic or wooden handle remains relatively cool to touch even though the handle is in direct contact

with the pot. This phenomenon is due to a property of matter known as *thermal conductivity*.

All materials conduct heat to some degree. When heat is applied to a body, the molecules at the point of application become violently agitated, strike the molecules next to them, and cause increased agitation. The process continues until the heat energy is distributed evenly throughout the material. Aluminum and copper are used for cooking pots because they conduct heat very readily to the food being cooked. Generally, metals are the best conductors of heat.

Among solids, there is a wide range of thermal conductivity. In the original example, the metal handle transmits heat from the pot to the hand with the possibility of burns. The wooden or plastic pot handle protects the hand since it does not conduct heat very well. Materials that are extremely poor conductors are called *insulators*. Insulators reduce heat transfer. Some examples of insulators are the wood handle of soldering irons, the finely spun glass or rock wool insulation in houses, and the tape or ribbon wrapping used on steam pipes.

Liquids are generally poor conductors of heat. Look at figure 4-1. The ice in the bottom of the test tube has not yet melted, although the water at the top is boiling. Water is such a poor conductor of heat that the rate of heating the water at the top of the tube is not sufficient to cause rapid melting of the ice at the bottom.

Since thermal conduction is a process by which molecular energy is passed on by actual contact, gases are the poorest conductors of heat because their

molecules are far apart and molecular contact is not pronounced. A double-pane window with an air space between the panes is an example of a relatively good insulator.

## Convection

Convection is the process by which heat is transferred by the flow of a liquid or gas. For example, an electron tube gets hotter and hotter until the air surrounding the tube begins to move. The motion of the air is upward because heated air expands in volume and becomes less dense and more buoyant than the surrounding denser cool air. The upward motion of the heated air carries the heat away from the hot tube by convection. Using a ventilating fan to move the air around a hot object is a fast method of transferring heat by convection. Copper fins increase the rate of cooling by conducting heat away from the hot tube. The fins provide large surfaces against which cool air can be blown.

Convection may take place in a liquid as well as in a gas. This happens when heat is transferred by a transformer in an oil bath. The hot oil in the bath is less dense (has less weight per unit volume) and rises. The cool oil falls, is heated, and then rises again. When the circulation of gas or liquid is not rapid enough to remove sufficient heat, using fans or pumps accelerates the motion of the cooling material. In some installations, pumps circulate water or oil to help cool large equipment. In airborne installations, electric fans and blowers are used to aid convection.

## Radiation

Conduction and convection do not account for all of the phenomena associated with heat transfer. For example, heating through convection cannot occur in front of an open fire because the air currents are moving toward the fire. Heating cannot occur through conduction because the conductivity of the air is very low, and the cooler currents of air moving toward the fire would overcome the transfer of heat outward. Conduction and convection take place only through molecular contact within some medium; therefore, heat must travel across space by some means other than conduction and convection. For example, heat from the sun reaches the Earth by some other method, as outer space is an almost perfect vacuum. The third method of heat transfer is known as radiation.

The term *radiation* refers to the continual emission of energy from the surface of all bodies. This energy is

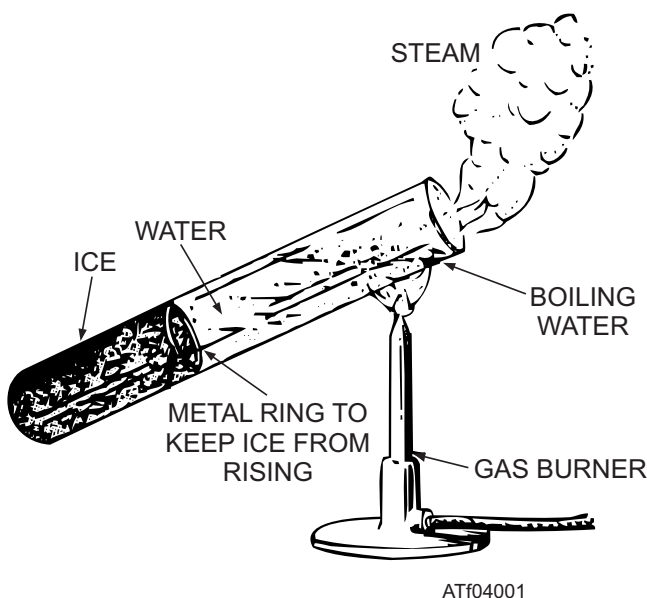

Figure 4-1.—Water is a poor conductor of heat.

known as radiant energy. Radiant energy is in the form of electromagnetic waves and is identical in nature to light waves, radio waves, and X-rays, except for a difference in wavelength. Sunlight is radiant heat energy that travels a great distance through space to reach the Earth. These electromagnetic heat waves are absorbed when they come in contact with nontransparent bodies. The motion of the molecules in the nontransparent body increases, as indicated by an increase in the temperature of the body.

### Conduction, Convection, and Radiation Compared

The differences between conduction, convection, and radiation are discussed below.

- Conduction and convection transfer heat slowly, while radiation takes place at the speed of light. You can see this at the time of an eclipse of the sun, when heat from the sun is shut off at the same time as light is shut out.
- Radiant heat may pass through a medium without heating it. For example, the air inside a greenhouse may be much warmer than the glass through which the sun's rays pass.
- Conducted or convected heat may travel in roundabout routes, while radiant heat always travels in a straight line. For example, radiation is cut off when a screen is placed between the source of heat and the body to be protected.

### Absorption

The sun, a fire, and an electric light bulb all radiate energy, but bodies need not glow to give off heat. A kettle of hot water or a hot soldering iron radiates heat. If the surface of a body is polished or light in color, less heat is radiated from the body. Bodies that do not reflect are good radiators and good absorbers. Bodies that do reflect are poor radiators and poor absorbers. This is the reason white clothing is worn in the summer. A practical example of heat control is the thermos bottle. The flask itself is made of two walls of silvered glass with a vacuum between them. The vacuum prevents the loss of heat by conduction and convection, and the silver coating reduces the loss of heat by radiation.

The silver-colored paint on the radiators in heating systems is used as decoration. Silver-colored paint actually decreases the efficiency of heat transfer. The most effective color for heat transfer is dull black. Dull black is the ideal absorber and also the best radiator.

## TEMPERATURE

If an object is hot when you touch it, it has a high temperature. If the object is cold when you touch it, it has a low temperature. In other words, temperature is a measure of the hotness or coldness of an object. The hotness and coldness of an object are relative. For example, on a cold day, metals seem colder to the touch than nonmetals because metals conduct heat away from the body more rapidly. When you leave a warm room to go outside, the outside air seems cooler than it really is. When you come from the outside cold into a warm room, the room seems warmer than it really is. The temperature a person feels depends on the state of temperature of the person's body at that exact moment of time.

### Temperature Scales and Conversions

There are many systems of temperature measurement, and often you need to convert from one to the other. The four most common scales (fig. 4-2) used today are the Fahrenheit (F), Celsius (C), Rankine (R), and Kelvin (K) scales.

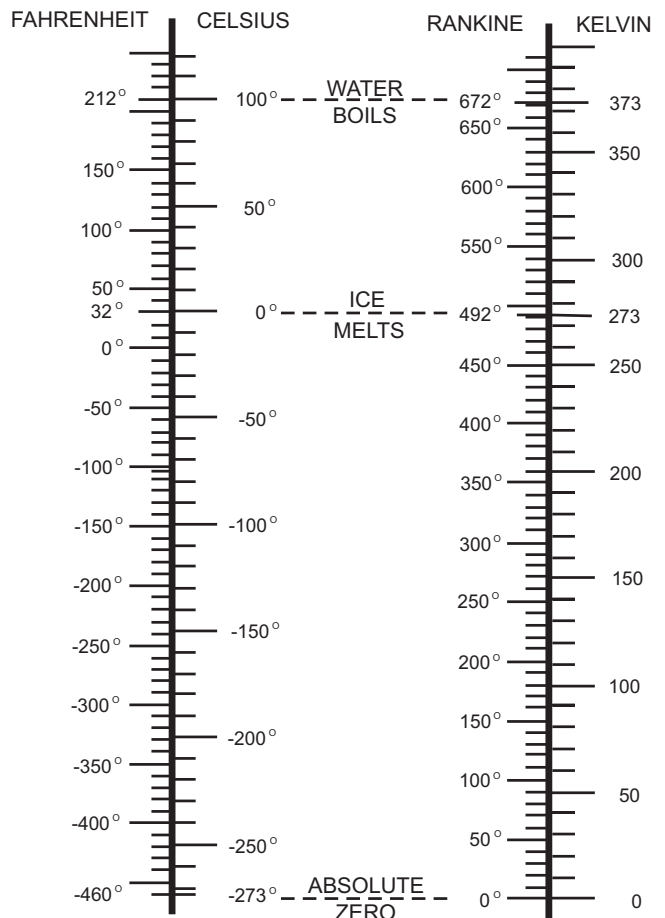

ATF04002

Figure 4-2.—Comparison of the four common temperature scales.

**FAHRENHEIT SCALE.**—The scale familiar to most Americans is the Fahrenheit scale. Its zero point approximates the temperature produced by mixing equal quantities (by weight) of snow and common salt.

Under standard atmospheric pressure, the boiling point of water is 212°F above zero, and the freezing point is 32°F above zero. Each degree represents an equal division, and there are 180 such divisions between freezing and boiling.

**CELSIUS SCALE.**—This scale uses the freezing point (0°C) and the boiling point (100°C) of water under standard atmospheric pressure as fixed points of 0 and 100 with 100 equal divisions between. The 100 divisions on the Celsius scale represent the same difference in temperature as 180 divisions of the Fahrenheit scale, creating a ratio of 100 to 180. The ratio of  $\frac{100}{180}$  reduces to  $\frac{5}{9}$ , which means a change of 1°F

is equal to a change of  $\frac{5}{9}$  °C. A change of 5° on the Celsius scale is equal to a change of 9° on the Fahrenheit scale. Because 0° on the Celsius scale corresponds to 32° on the Fahrenheit scale, a difference in reference points exists between the two scales. (See fig. 4-2.)

The Celsius scale is used with most scientific measurements. In your work, you will need to convert Fahrenheit temperatures to their Celsius equivalents. To convert from the Fahrenheit scale to the Celsius scale, you subtract 32° from the Fahrenheit temperature and multiply the result by  $\frac{5}{9}$ . For example, to convert 68° Fahrenheit (F) to Celsius (C), you would perform the following calculations:

$$C = \frac{5}{9}(F - 32)$$

$$C = \frac{5}{9}(68 - 32)$$

$$C = \frac{5}{9} \times 36 = 20 \text{ C}$$

To convert from the Celsius scale to the Fahrenheit scale, you reverse the process. Multiply the reading on the Celsius thermometer by  $\frac{9}{5}$  and add 32 to the result.

$$F = \frac{9}{5} \times C + 32$$

$$F = \frac{9}{5} \times 20 + 32$$

$$F = 36 + 32 = 68 \text{ F}$$

Another method of temperature conversion is based on the fact that the Fahrenheit and Celsius scales both register the same temperature at -40°; that is, -40°F is equivalent to -40°C. This method of conversion is known as the *40 rule*, and you can use the following steps:

Step 1. Add 40 to the temperature that is to be converted. Do this whether the given temperature is Fahrenheit or Celsius.

Step 2. Multiply the result by  $\frac{9}{5}$  when changing Celsius to Fahrenheit; multiply by  $\frac{5}{9}$  when changing Fahrenheit to Celsius.

Step 3. Subtract 40 from the result of step 2. This is the answer.

For example, to convert 100°C to the Fahrenheit scale using the 40 rule, perform the following calculations:

$$100 + 40 = 140$$

$$140 \times \frac{9}{5} = 252$$

$$252 - 40 = 212 \text{ F}$$

Remember, always ADD 40 first, then MULTIPLY, then SUBTRACT 40, regardless of the direction of the conversion.

It is important that all technicians be able to read thermometers and to convert from one scale to the other. In some types of electronic equipment, thermometers are provided as a check on operating temperatures. Thermometers also are used to check the temperature of a charging battery.

**RANKINE SCALE.**—The Rankine scale has the same spacing between degrees as the Fahrenheit scale. Its zero point corresponds to 0 Kelvin (absolute zero). This point is calculated as the equivalent of -459.69°F; usually, -460°F is used for calculations. To convert Fahrenheit to Rankine, add 460 to the Fahrenheit temperature.

**KELVIN SCALE.**—The Kelvin scale is also known as an absolute scale. Its zero point is the temperature at which all molecular motion ceases and no additional heat can be extracted from a substance. The zero point on the Kelvin scale is referred to as absolute zero temperature (fig. 4-2), which is -273.15°C (commonly used as -273°C for most calculations). The spacing between degrees is the same

as for the Celsius scale; adding 273 to the Celsius temperature converts the Celsius temperature to the Kelvin temperature.

Since Kelvin and Rankine both have the same zero point, conversion between the two scales requires no addition or subtraction. The Kelvin temperature is equal to  $\frac{5}{9}$  of the Rankine temperature, and the Rankine temperature is equal to  $\frac{9}{5}$  of the Kelvin temperature.

### Thermal Expansion

Nearly all substances expand, or increase in size, when their temperature increases. Railroad tracks are laid with small gaps between the sections to prevent buckling when the temperature increases in summer. Concrete pavement has strips of soft material inserted at intervals to prevent buckling when the sun heats the roadway. A steel building or bridge is put together with red-hot rivets so that when the rivets cool they will shrink, and the separate pieces that the rivets connect will be pulled together very tightly.

As a substance is expanded by heat, the weight per unit volume decreases. This decrease occurs because the weight of the substance remains the same while the volume is increased by the application of heat. This is why density decreases with an increase in temperature.

For a given change in temperature, the change in length or volume is different for each substance. For example, a given change in temperature causes a piece of copper to expand nearly twice as much as a piece of glass of the same size and shape. For this reason, the connecting wires into an electronic tube are not made of copper; they are made of a metal that expands at the same rate as glass. If the metal does not expand at the same rate as the glass, the vacuum in the tube would be broken by air leaking past the wires in the glass stem.

The amount that a unit length of any substance expands for a 1°C rise in temperature is known as the *coefficient of linear expansion* for that substance. The temperature scale used must be specified.

To estimate the expansion of any object, such as a steel rail, you must know three things about it—its length, the rise in temperature to which it is subjected, and its rate or coefficient of expansion. The equation for linear expansion is expressed as follows:

$$\Delta l = \alpha l \Delta T$$

In this equation,  $\Delta l$  is the change in length,  $\alpha$  represents the coefficient of linear expansion for the particular substance,  $l$  represents the original length, and  $\Delta T$  is the difference between the two temperatures.

Use the formula shown above to solve the following problem:

If a steel rod measures exactly 9 feet at 21°C, what is its length at 55°C? The coefficient of linear expansion for steel is  $11 \times 10^{-6}$  per °C.

$$\text{Linear expansion} = (11 \times 10^{-6}) \times 9 \times (55 - 21)$$

$$\text{Linear expansion} = 0.000011 \times 9 \times 34$$

$$\text{Linear expansion} = 0.003366 \text{ feet}$$

This amount, when added to the original length of the rod, makes the rod 9.003366 feet long. (Since the temperature has increased, the rod is longer by the amount of expansion. If the temperature had been lowered, the rod would have become shorter by a corresponding amount.)

The increase in the length of the rod is relatively small; but if the rod were placed where it could not expand freely, there would be a tremendous force exerted due to thermal expansion. Thermal expansion is taken into consideration in the design of aircraft, ships, buildings, and all forms of machinery.

Refer to table 4-1 for a list of the coefficients of linear expansion (approximate values) of some substances per °C.

Table 4-1.—Linear Expansion Coefficients

SUBSTANCE	COEFFICIENT OF LINEAR EXPANSION PER C°
Aluminum	$23 \times 10^{-6}/C^{\circ}$
Brass	$19 \times 10^{-6}/C^{\circ}$
Copper	$17 \times 10^{-6}/C^{\circ}$
Glass	4 to $9 \times 10^{-6}/C^{\circ}$
Kovar	4 to $9 \times 10^{-6}/C^{\circ}$
Lead	$28 \times 10^{-6}/C^{\circ}$
Iron, Steel	$11 \times 10^{-6}/C^{\circ}$
Quartz	$0.4 \times 10^{-6}/C^{\circ}$
Zinc	$26 \times 10^{-6}/C^{\circ}$

A practical application for the difference in the coefficients of linear expansion is the thermostat. This instrument is made of two strips of different metals fastened together. When the temperature changes, the strip bends because of the unequal expansion of the metals (fig. 4-3). Thermostats (fig. 4-4) are used in overload relays for motors, in temperature-sensitive switches, and in electric ovens.

The coefficient of surface or area expansion is approximately twice the coefficient of linear expansion. The coefficient of volume expansion is approximately three times the coefficient of linear expansion. It is an interesting fact that in a plate that contains a hole, the area of the hole expands at the same rate as the surrounding material. In the case of a volume of air enclosed by a thin solid wall, the volume of air expands at the same rate as that of a solid body made of the same material as the walls.

### THERMOMETERS

The measurement of temperature is known as *thermometry*. Many thermometers use liquids in sealed containers. The best liquids to use in the construction of thermometers are alcohol and mercury because these liquids have low freezing points. Solid thermometers are used to measure temperatures below freezing and above boiling points of alcohol and mercury.

#### Liquid Thermometers

The common laboratory thermometer is constructed to indicate a change of 1° in temperature. A bulb is blown at one end of a piece of glass tubing that has a small bore. Then, the tube and bulb are filled with a liquid. During this process, the temperature of both the liquid and the tube are kept at a point higher than the

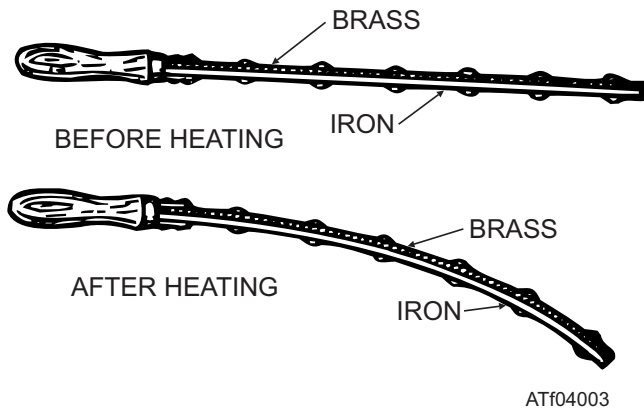

Figure 4-3.—Compound bar.

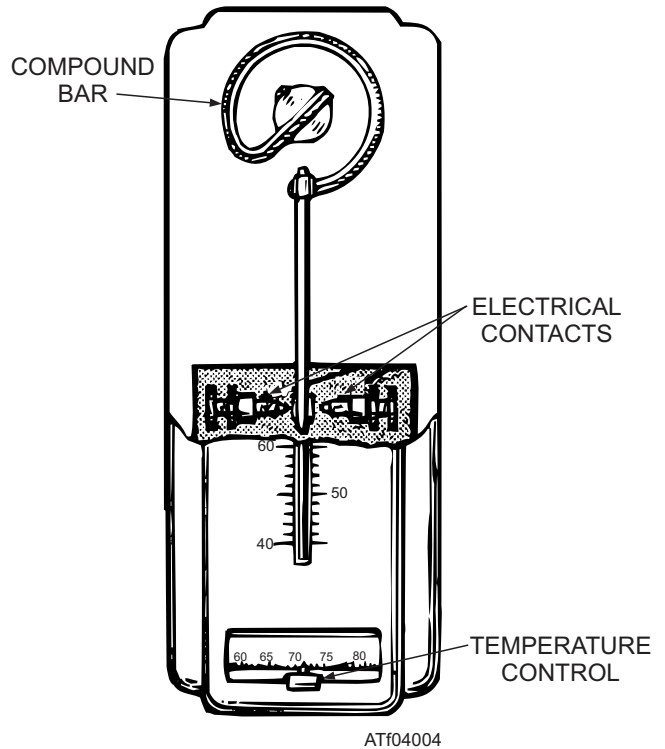

Figure 4-4.—Thermostat.

thermometer will reach in normal usage. The glass tube is sealed, and the thermometer is allowed to cool. During the cooling process, the liquid falls away from the top of the tube and creates a vacuum in the thermometer. When a thermometer is calibrated, it is placed in melting ice, and the height of the cooled liquid column is marked as the 0°C point. Next, the thermometer is placed in steam at a pressure of 76 centimeters of mercury, and a mark is made at the point to which the liquid inside rises. The space between these two marks is then divided into 100 equal parts (degrees on the Celsius thermometer). This type of thermometer is used in laboratory work and in testing electrical equipment.

#### Solid Thermometers

Because the range of all liquid thermometers is limited, other methods of thermometry are necessary. Most liquids freeze at temperatures between 0°C and -200°C. At the upper end of the temperature range, high heat levels are encountered. Here, the use of liquid thermometers is limited by the high vapor pressures of the liquids. The resistance thermometer and the thermocouple are among the most widely used solid thermometers.



The *resistance thermometer* makes use of the fact that the electrical resistance of metals changes as the temperature changes. This type of thermometer is usually constructed of platinum wire wound on a mica form and enclosed in a thin-walled silver tube. The resistance thermometer is extremely accurate from the lowest temperature to the melting point of the unit.

The *thermocouple* (fig. 4-5) is an electric circuit. Its operation is based on the principle that when two unlike metals are joined and the junction is at a different temperature from the remainder of the circuit, an electromotive force is produced. The electromotive force is measured with great accuracy by a galvanometer. Thermocouples can be located wherever measurement of the temperature is important and wires run to a galvanometer located at any convenient point. By means of a rotary selector switch, you can use one galvanometer to read the temperatures of thermocouples at any of a number of widely separated points.

The principle of the compound bar (fig. 4-3) also is used in thermometers. The bar may be in the shape of a spiral or a helix, so, within a given enclosure, a greater length of the compound bar may be used. This increases the movement of the free end per degree of temperature change. Also, the indicating pointer may be joined to the moving end of the compound bar by means of distance multiplying linkage to make the thermometer easier to read. Often this linkage is arranged to give circular movement to the pointer.

## MEASUREMENT OF HEAT

A unit of heat may be defined as the heat necessary to produce some agreed-on standard of change. Three such units in common use are the British thermal unit (Btu), the gram-calorie, and the kilogram-calorie.

- One Btu is the quantity of heat necessary to raise the temperature of 1 pound of water 1°F.

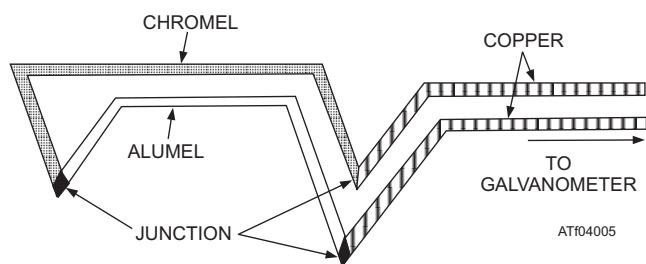

Figure 4-5.—Thermocouple.

- One gram-calorie (small calorie) is the quantity of heat necessary to raise 1 gram of water 1°C.
- One kilogram-calorie (large calorie) is the quantity of heat necessary to raise 1 kilogram of water 1°C. One kilogram-calorie equals 1,000 gram-calories.

**NOTE:** The large calorie is used in relation to food energy and for measuring comparatively large amounts of heat. In this manual, the term *calorie* means gram-calorie.

The terms *quantity of heat* and *temperature* are commonly misused. The distinction between them should be understood clearly. For example, two identical pans that contain different amounts of water of the same temperature are placed over identical gas burner flames for the same length of time. At the end of that time, the smaller amount of water reaches a higher temperature. Equal amounts of heat have been supplied for each pan of water, but water temperatures are **not** equal. In another example, the water in both pans is the same temperature (80°F), and both pans are heated to the boiling point. More heat must be supplied to the larger amount of water. The temperature rises are the same for both pans, but the quantities of heat necessary to make the temperatures rise are different.

## Mechanical Equivalent

Mechanical energy is usually expressed in ergs, joules, or foot-pounds. Energy in the form of heat is expressed in calories or in Btu—4.186 joules equals 1 gram-calorie and 778 foot-pounds equals 1 Btu. The following equation is used to convert from the English system to the metric system:

$$1 \text{ Btu} = 252 \text{ calories}$$

## Specific Heat

Substances differ from one another in the different quantities of heat they require to produce the same temperature change in a given mass of substance. The *thermal capacity* of a substance is the calories of heat needed per gram mass to increase the temperature 1°C. The *specific heat* of a substance is the ratio of its thermal capacity to the thermal capacity of water at 15°C. Specific heat is the same numerically in the English and the metric systems.

Water has a high heat capacity. Large bodies of water on the Earth stabilize the air and the surface temperature of the Earth. A great quantity of heat is

required to change the temperature of a large lake or river. When the temperature of the air falls below the temperature of bodies of water, the bodies of water give off large quantities of heat to the air. This process keeps the atmospheric temperature at the surface of the Earth from changing rapidly.

Table 4-2 gives the specific heats of several common substances. To find the heat required to raise the temperature of a substance, multiply its mass by the rise in temperature times its specific heat.

**Table 4-2.—Specific Heats of Some Common Substances**

Hydrogen (at constant pressure)	3.409
Water at 4°C	1.0049
Water at 15°C	1.0000
Water at 30°C	0.9971
Ice at 0°C	0.502
Steam at 100°C	0.421
Air (at constant pressure)	0.237
Aluminum	0.217
Glass	0.160
Iron	0.114
Copper	0.093
Brass, zinc	0.092
Silver	0.057
Tin	0.056
Mercury	0.033
Gold, lead	0.031

For example, it takes 1,000 Btu to raise the temperature of 100 pounds of water 10°F, but only 31 Btu to raise 100 pounds of lead 10°F.

## CHANGE OF STATE

Changing matter between solid and liquid form involves heat of fusion, and between liquid and vapor form involves heat of vaporization.

### Heat of Fusion

A thermometer placed in melting snow behaves strangely. The temperature of the snow rises slowly until it reaches 0°C. Then, provided the mixture is stirred constantly, the temperature remains at 0°C until

all the snow has changed to water. When all the snow has melted, the temperature again begins to rise. A definite amount of heat is required to change the snow to water at the same temperature. This heat is required to change the water from crystal form to liquid form.

Eighty gram-calories of heat are required to change 1 gram of ice at 0°C to water at 0°C. In English units, the heat required to change 1 pound of ice at 32°F to water at 32°F is 144 Btu. These values (80 gram-calories and 144 Btu) are called the *heat of fusion* of water. The heat used to melt the ice represents the work done to produce the change of state. Since 80 calories are required to change a gram of ice to water at 0°C, when a gram of water is frozen, the gram of water gives up 80 calories.

Many substances behave very much like water. At a given pressure, the substances have a definite heat of fusion and an exact melting point. However, there are many materials that do not change from a liquid to a solid state at one temperature. For example, molasses gets thicker and thicker as the temperature decreases, and glass is at a lower temperature when it begins to liquefy than when it completes the process, but there are no exact temperatures where the change of state occurs. Wax, celluloid, and butter are other substances that do not change from a liquid to a solid state at any particular temperature.

### Heat of Vaporization

Damp clothing dries more rapidly under a hot iron than under a cold one. A pool of water evaporates more rapidly in the sun than in the shade. Therefore, heat has something to do with evaporation. The process of changing a liquid to a vapor is similar to what occurs when a solid melts.

If a given quantity of water is heated until it evaporates (changes to a gas [vapor]), more heat is used than is necessary to raise the same amount of water to the boiling point. For example, 540 calories are required to change 1 gram of water to vapor at a temperature of 100°C. It takes 972 Btu to change 1 pound of water to water vapor (steam) at a temperature of 212°F. The amount of heat necessary for this change is called the *heat of vaporization* of water. Over five times as much heat is required to change a given amount of water to vapor than to raise the same amount of water from the freezing point to the boiling point.

When water is heated, some vapor forms before the boiling point is reached. As the water molecules take up more and more energy from the heating source, their

kinetic energy increases. The motion that results from the high kinetic energy of the water molecules causes a pressure, which is called the *vapor pressure*. As the velocity of the water molecules increases, the vapor pressure increases. The *boiling point* of a liquid is the temperature at which the vapor pressure equals the external or atmospheric pressure. At normal atmospheric pressure at sea level, the boiling point of water is 100°C or 212°F.

**NOTE:** At sea level, atmospheric pressure is normally 29.92 inches of mercury.

While the water is below the boiling point, a number of molecules acquire enough kinetic energy to break away from the liquid state into a vapor. For this reason, some evaporation slowly takes place below the boiling point. At or above the boiling point, large numbers of molecules have enough energy to change from liquid to vapor, and the evaporation takes place much more rapidly. If the molecules of water are changing to water vapor in an open space, the air currents carry them away quickly. In a closed container, the molecules become crowded and some of them bounce back into the liquid as a result of collisions. When as many molecules are returning to the liquid state as are leaving it, the vapor is saturated. Experiments show that saturated vapor in a closed container exerts a pressure and has a given density at every temperature.

- Q4-1. *The two most common theories about the nature of heat are the kinetic theory and the \_\_\_\_\_ theory.*
- Q4-2. *The three methods of heat transfer are conduction, convection, and \_\_\_\_\_.*
- Q4-3. *The metal handle of a hot pot will burn your hand while a plastic or wooden handle remains relatively cool to touch, even though it is in direct contact with the pot. This phenomenon is due to a property of matter known as thermal \_\_\_\_\_.*
- Q4-4. *\_\_\_\_\_ is the process by which heat is transferred by the flow of a liquid or gas.*
- Q4-5. *Radiant heat energy is in the form of \_\_\_\_\_ waves.*
- Q4-6. *The most effective color for heat transfer and the ideal absorber is dull \_\_\_\_\_.*
- Q4-7. *The four most common scales used to measure temperature are Fahrenheit, Celsius, Rankine, and \_\_\_\_\_.*

- Q4-8. *Under standard atmospheric pressure, using the Fahrenheit scale, the boiling point of water is (a) \_\_\_\_\_° above zero, and the freezing point is (b) \_\_\_\_\_° above zero.*
- Q4-9. *30° Celsius is equal to \_\_\_\_\_° on the Fahrenheit scale.*
- Q4-10. *The Kelvin scale is also known as the (a) \_\_\_\_\_ scale, and the spacing between degrees on the Kelvin scale is the same as the spacing between degrees on the (b) \_\_\_\_\_ scale.*
- Q4-11. *The Rankine scale has the same spacing between degrees as the \_\_\_\_\_ scale.*
- Q4-12. *The amount that a unit length of any substance expands for a 1° rise in temperature is known as the coefficient of \_\_\_\_\_ expansion for that substance.*
- Q4-13. *The measurement of temperature is known as \_\_\_\_\_.*
- Q4-14. *The common liquid laboratory thermometer is constructed so it indicates a change of \_\_\_\_\_° in temperature.*
- Q4-15. *The \_\_\_\_\_ thermometer makes use of the fact that the electrical resistance of metals changes as the temperature changes.*
- Q4-16. *One \_\_\_\_\_ is the quantity of heat necessary to raise the temperature of 1 pound of water 1°F.*
- Q4-17. *How many calories are equal to 1 Btu? \_\_\_\_\_*
- Q4-18. *The \_\_\_\_\_ heat of a substance is the ratio of its thermal capacity to the thermal capacity of water at 15°C.*
- Q4-19. *The values 80 gram-calories and 144 Btu are called the heat of \_\_\_\_\_ of water.*
- Q4-20. *Over \_\_\_\_\_ times as much heat is required to change a given amount of water to vapor than to raise the same amount of water from the freezing point to the boiling point.*

## WAVE PARAMETERS

**LEARNING OBJECTIVES:** Identify the terms used to describe wave parameters. Identify the factors involved in wave motion and recognize various types of waves, to include transverse waves, longitudinal waves,

and standing waves. Recognize the various properties common to all waves such as propagation, reflection, refraction, diffraction, and interference. Describe the principle known as the Doppler effect.

The term *wave parameter* is a general term and applies to all types of waves—water, radio, sound, light, and heat. All types of waves exhibit some common characteristics, such as propagation, reflection, refraction, interference, and diffraction.

## TERMS USED IN WAVE PARAMETERS

The characteristic properties of waves discussed in the following paragraphs are descriptive of all waves.

**Propagation.** The transfer of energy in wave form. In the case of sound waves, wave energy must pass through an elastic medium. An elastic medium is required for the propagation of mechanical energy such as sound waves but is not required for that of electromagnetic waves. The propagation of electromagnetic waves in free space can be illustrated by the transmission of information back to Earth by satellites from the outer regions of our solar system. For the transmission of electromagnetic waves, periodic oscillations of accelerating electrons in a conductor (such as an antenna) give rise to periodically reversing electric and magnetic fields that propagate in free space away from their source at the speed of light (300,000 kilometers per second).

**Frequency.** The frequency of any periodic motion is the number of complete variations (cycles) per unit of time. With waves, the time unit is the second, and the frequency unit is the hertz (Hz). A hertz is the number of complete cycles per second or the number of complete waves that pass a given point each second.

**Period.** The period of a wave is the time required to complete a full cycle. The period and the frequency of a given wave are reciprocals of each other. The period of a wave can be expressed mathematically as follows:

$$\text{Period} = \frac{1}{\text{frequency}}$$

and

$$\text{Frequency} = \frac{1}{\text{period}}$$

If a sound wave has a frequency of 400 Hz, its period is  $\frac{1}{400}$  or 0.0025 second. If successive crests of a

water wave pass a given point every 5 seconds, the frequency of the wave is  $\frac{1}{5}$  or 0.2 Hz.

**Velocity.** The velocity of propagation is the rate at which the disturbance transverses the medium or the velocity with which the crest of the wave moves along. The velocity of the wave must not be confused with the speed of a particle, which is always less than the velocity of the wave. The velocity of the wave depends on both the type of wave and the nature of the medium, if any.

**Wavelength.** Wavelength, shown by the symbol  $\lambda$  (Greek lambda), is the distance along the direction of propagation of the wave between two successive points in the medium that are at precisely the same state of disturbance. In a water wave, this is the distance between two adjacent crests. Wavelength depends on both the frequency ( $f$ ) of the wave and the velocity ( $v$ ) of propagation of the wave in a given medium, if any. Wavelength is expressed mathematically as follows:

$$\text{Wavelength} = \frac{\text{velocity}}{\text{frequency}}$$

or

$$v = f\lambda$$

Wavelength and velocities must be in compatible units. If frequency is specified in waves per second (in hertz), velocity must be in distance units per second (feet per second or meters per second). If velocity is in feet per second, wavelength should be in feet. If velocity is in meters per second, wavelength should be in meters.

## WAVE MOTION

Energy is transferred progressively from point to point in a medium by a disturbance that may have the form of an elastic deformation, a variation of pressure, electric or magnetic intensity, electric potential, or temperature. This disturbance advances with a finite velocity through a medium. Energy is transferred from one point to another without the passage of matter between the two points (although in some cases particles of matter do move to and fro around their equilibrium position). A single disturbance induced into the medium is called a *wave pulse*, and a series of waves produced by continuous variations is called a *train of waves* or *wave train*. These may be transverse, longitudinal, or standing waves.

## Transverse Waves

A periodic wave is a transverse wave if the disturbance takes place at right angles to the direction of propagation. You can see this motion by fastening one end of a piece of string to a stanchion and moving its free end up and down with a simple periodic motion. The motion of the waves will be along the length of the line, but each particle of the line moves at right angles to its length.

Electromagnetic waves do not involve moving particles of matter. Electromagnetic waves rely on electric and magnetic force fields. Electromagnetic waves are transverse waves since the variations of these fields also are at right angles to the direction of wave movement. Also, the variations of electric-field intensity and those of magnetic-field intensity are at right angles to each other as well as to the direction of propagation of the wave. For example, if an electromagnetic wave is moving toward the north and is horizontally polarized, the variations of the electric-field intensity are east-west horizontal to the Earth's surface, while variations in the magnetic-field intensity are vertical. Electromagnetic waves are radio waves, heat rays, light rays, etc., depending on their frequency.

## Longitudinal Waves

Longitudinal waves are waves in which the disturbance takes place in the direction of propagation. The compressional waves that constitute sound, such as those set up in air by a vibrating tuning fork, are longitudinal waves. See figure 4-6. When struck, the tuning fork sets up a vibrating motion. As the tine moves in an outward direction, the air immediately in front of the tine is compressed so that its momentary pressure is raised above that of other points in the surrounding medium. Because air is elastic, this disturbance is transmitted progressively in an outward direction as a compression wave. When the tine returns and moves in the inward direction, the air in front of the tine is rarefied so that its momentary pressure is reduced below that at other points in the surrounding medium. This disturbance also is propagated, but in the form of a rarefaction (expansion) wave, and follows the compression wave through the medium. The compression and expansion waves are longitudinal waves because the particles of matter of the medium move back and forth longitudinally in the direction of wave travel.

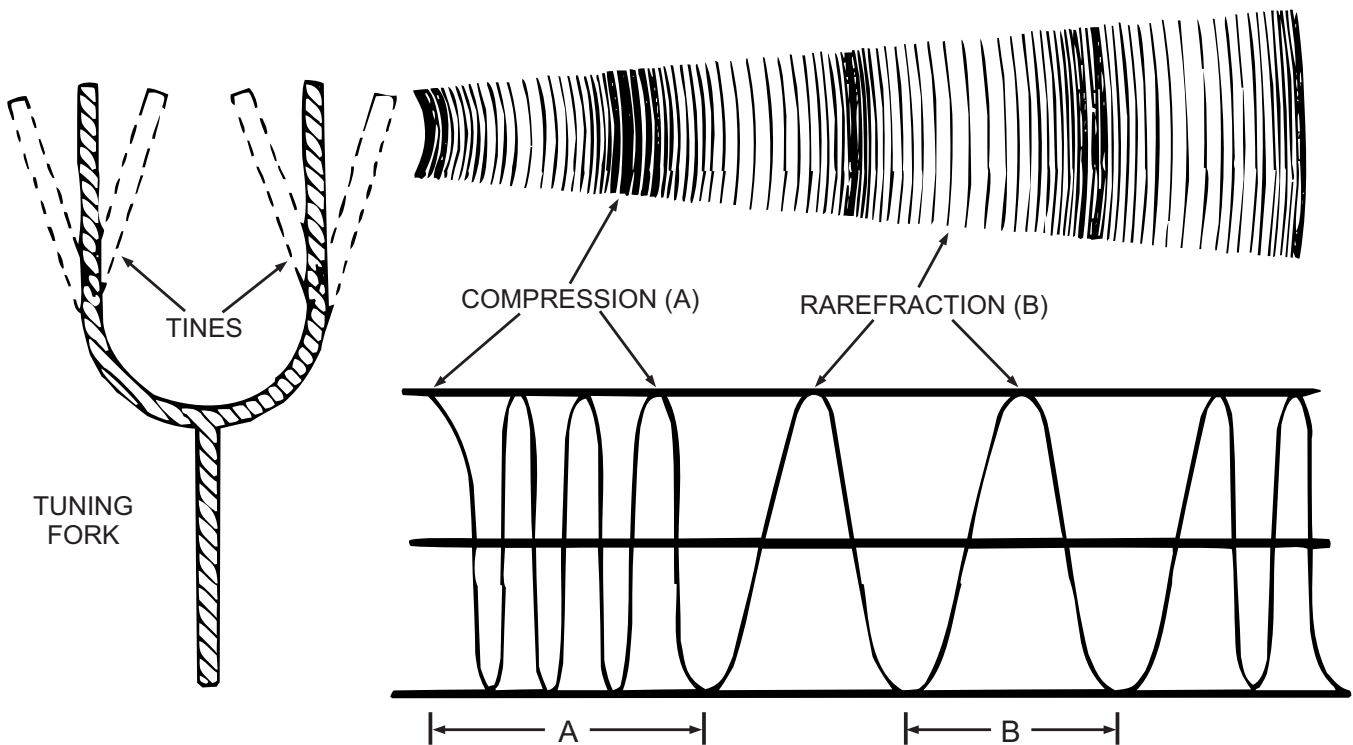

AT04006

Figure 4-6.—Compression and expansion wave propagation.

## Standing Waves

Standing waves are produced by the interference of two periodic waves of the same amplitude and wavelength traveling in opposite directions in the same medium, whether the medium is a solid, liquid, or gas. No standing wave can be produced if the two wave trains have different wavelengths. Figure 4-7 shows the formation of a standing wave represented by the solid curved line. The points A and N along the horizontal axis of the graph are fixed points within the medium and are stationary or standing. Points N are the locations within the medium where the amplitude of the standing wave is always minimum or zero and are called *nodes*. Successive nodes are a half wavelength apart. Halfway between the nodes are the *antinodes* (or loops), represented by points A on the graph. The standing wave reaches its maximum amplitude at point A (a quarter-wavelength from a node). The dotted curved line represents a wave train traveling from left to right, and the dashed curved line represents an equal wave train traveling from right to left. The wave trains in figure 4-7 appear as if each were the only wave within the medium. As the two wave trains combine to form a standing wave (shown by the solid curved line in fig. 4-7), they cease to exist in their original form.

The top drawing of figure 4-7 shows the crests of the two identical component waves approaching each other and coinciding at points A. At this time, the standing wave will increase to maximum amplitude equal to the sum of the two components.

The lower drawing in figure 4-7 shows the crests of the component waves passing each other, and the standing wave decreasing to zero at the time the two component waves exactly neutralize each other. After this, the standing wave will increase in amplitude in the opposite direction from that in the drawings. You can see that the points of maximum variation of the standing wave are not moving, and that at points N, the magnitudes of the two component waves are the same and their deviations are opposite; therefore, at points N, the standing wave is always equal to zero.

## REFLECTION

Lines drawn from the source of waves to indicate the path along which the waves travel are called rays. Often, these lines are used in illustrations to show wave propagation. When several rays are drawn from a nearby source, the rays are shown as diverging from the source. Rays drawn from a distant source are usually shown as being parallel.

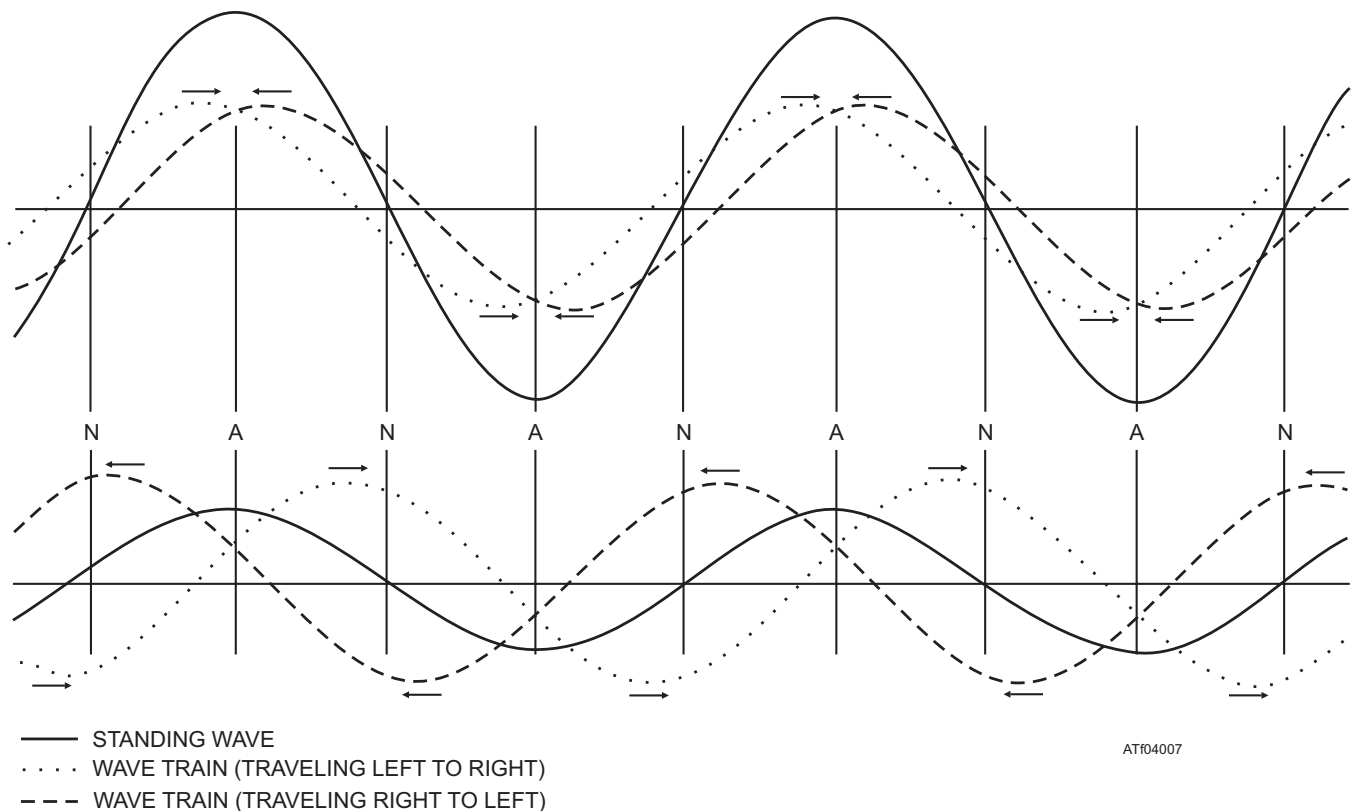

Figure 4-7.—Formation of a standing wave.

A *wave front* is a surface on which the phase of the wave has the same value at all points at a given instant. Wave fronts near the source are sharply curved. As their distance from the source increases, wave fronts become nearly flat.

Within a uniform medium, a ray travels in a straight line. Only at the boundary of two media, or in an area where the velocity of propagation of the wave within the medium changes, do the rays change their direction.

When an advancing wave front meets a medium of different characteristics, some of its energy is reflected back into the initial medium, and some of its energy is transmitted into the second medium. In the second medium, the wave front continues at a different velocity or is absorbed by the medium. In some cases, all three processes (reflection, absorption, and transmission) may occur.

Refer to figure 4-8, showing a reflected wave. *Reflected waves* are waves that are neither transmitted nor absorbed but are thrown back from the surface of the medium they meet. If a ray is directed against a reflecting surface, the ray striking the surface is called the *incident ray*, and the ray that bounces back is called the *reflected ray*. An imaginary line perpendicular to the reflecting surface at the point of impact of the incident ray is called the “normal.” The angle between the incident ray and the normal is called the *angle of incidence*. The angle between the reflected ray and the normal is called the *angle of reflection*.

The law of reflection states, “The angle of incidence is equal to the angle of reflection.” If the surface of the medium contacted by the incident rays of the wave is smooth, flat, and polished (a mirror surface), each reflected ray is thrown back at the same angle as the incident ray. The path of the ray reflected from the surface forms an angle exactly equal to the one formed by the path of the ray in reaching the medium. This conforms to the law of reflection.

The amount of incident wave energy that is reflected from a surface depends on the nature of the surface and the angle at which the wave strikes the surface. The amount of wave energy that is reflected increases as the angle of incidence increases. The amount of energy that is reflected is greatest when the incident ray is nearly parallel to the surface. When the incident ray is perpendicular to the surface, more of the wave energy is transmitted into the substance and less energy is reflected. At any angle of incidence, a mirror reflects almost all of the wave energy, and a dull black surface reflects very little of the wave energy. Waves that are reflected directly back toward the source cause standing waves.

## REFRACTION

When a wave passes from one medium into a medium having a different velocity of propagation for the wave, and if the ray is not perpendicular to the boundary between the two media, the wave changes direction or bends. This is called *refraction*, as shown in

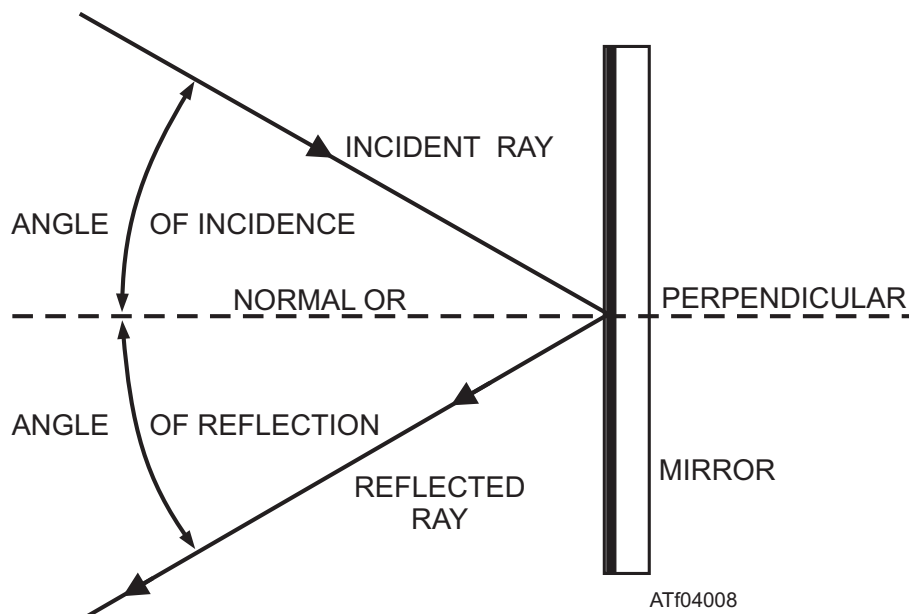

Figure 4-8.—Reflection of a wave.

figure 4-9. The ray striking the boundary is the incident ray, and the imaginary line perpendicular to the boundary is the normal. The angle between the normal and the path of the ray through the second medium is the angle of refraction.

An incident light ray is shown from points A to B in figure 4-9. As the ray reaches the boundary between the air and the top of the glass plate, it bends toward the normal and takes the path BC through the glass. The ray becomes the refracted ray from B to C. The angle formed by the refracted ray and the normal to the lower surface is the second angle of incidence. As the ray passes from the glass to the air, the ray is again refracted, this time away from the normal, and takes the path CD.

Refraction follows a general rule: When a ray passes from one medium into another having a lower velocity of propagation for the waves, refraction is toward the normal, so the angle of refraction ( $r$ ) is smaller than the angle of incidence ( $i$ ); when a ray passes into a medium having a higher velocity of propagation for the waves, refraction is away from the normal, so the angle of refraction ( $r_1$ ) is larger than the angle of incidence ( $i_1$ ). The angle of refraction depends on two factors: (1) the angle of incidence and (2) the index of refraction.

The index of refraction is the ratio of the velocities of the waves within the two media. The greater the

angle of incidence, the greater the bending; the greater the difference between the velocities of propagation in the two media, the greater the bending.

When the two surfaces of glass are parallel, the ray leaving the glass is parallel to the ray entering the glass. The distance between these two paths (between lines AE and CD in fig. 4-9) is called *lateral displacement*. When the incident ray is directed along the normal, lateral displacement is zero. Lateral displacement increases as the angle of incidence increases. Lateral displacement is greater in thick glass than in thin glass.

A boundary between two media does not always have a sharp point of transition, such as from the surface of glass to air. Air layers above the Earth's surface have different temperatures that cause variation in refraction of sound waves. Thermal layers in the ocean also cause variations in refraction. Variations in the ionosphere cause refraction of radio waves and light rays.

When a wave encounters a medium that has a higher velocity of propagation, refraction is away from the normal, and the angle of refraction is larger than the angle of incidence. When the angle of incidence is increased to the angle at which the refracted wave approaches  $90^\circ$  to the normal (parallel with the boundary), the angle of incidence reaches an angle called the *critical angle of refraction*. Any angle of incidence larger than this results in total reflection of

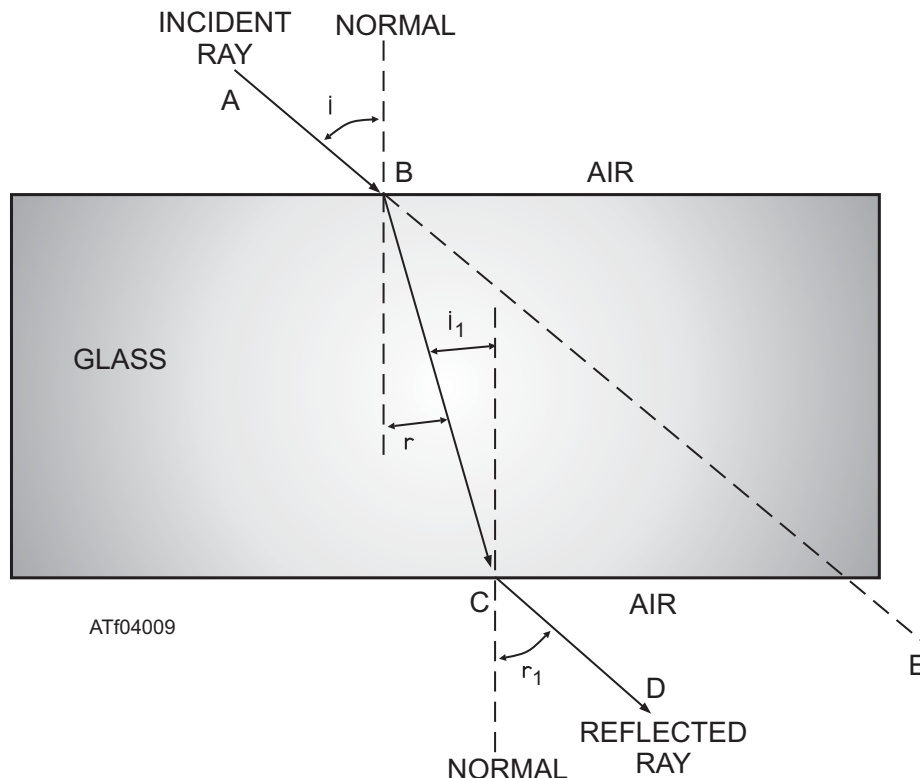

Figure 4-9.—Refraction of a wave.



the incident wave. The size of the critical angle of refraction depends on the index of refraction of the two media. The larger the index of refraction, the smaller the critical angle of refraction.

**DIFFRACTION**

Diffraction is the bending of the path of waves around an obstruction. This is very easy to observe in water waves. Generally, the lower frequency waves diffract more than do those at higher frequency. You can hear the diffraction in sound waves by listening to music from an outdoor source. Then, step behind a

solid obstruction, such as a brick wall. The high notes that have less diffraction seem reduced in loudness more than the low notes. Figure 4-10 shows broadcast band radio waves traveling over to the opposite side of a mountain from their source because of diffraction. Higher frequency TV signals from the same city might not be detected on the opposite side of the same mountain as depicted in figure 4-10.

**INTERFERENCE**

The general term *interference* is used to describe the effects produced by two or more waves that occupy

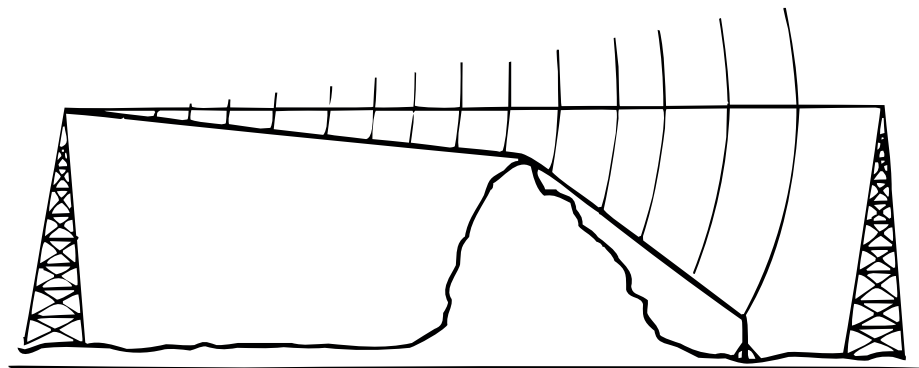
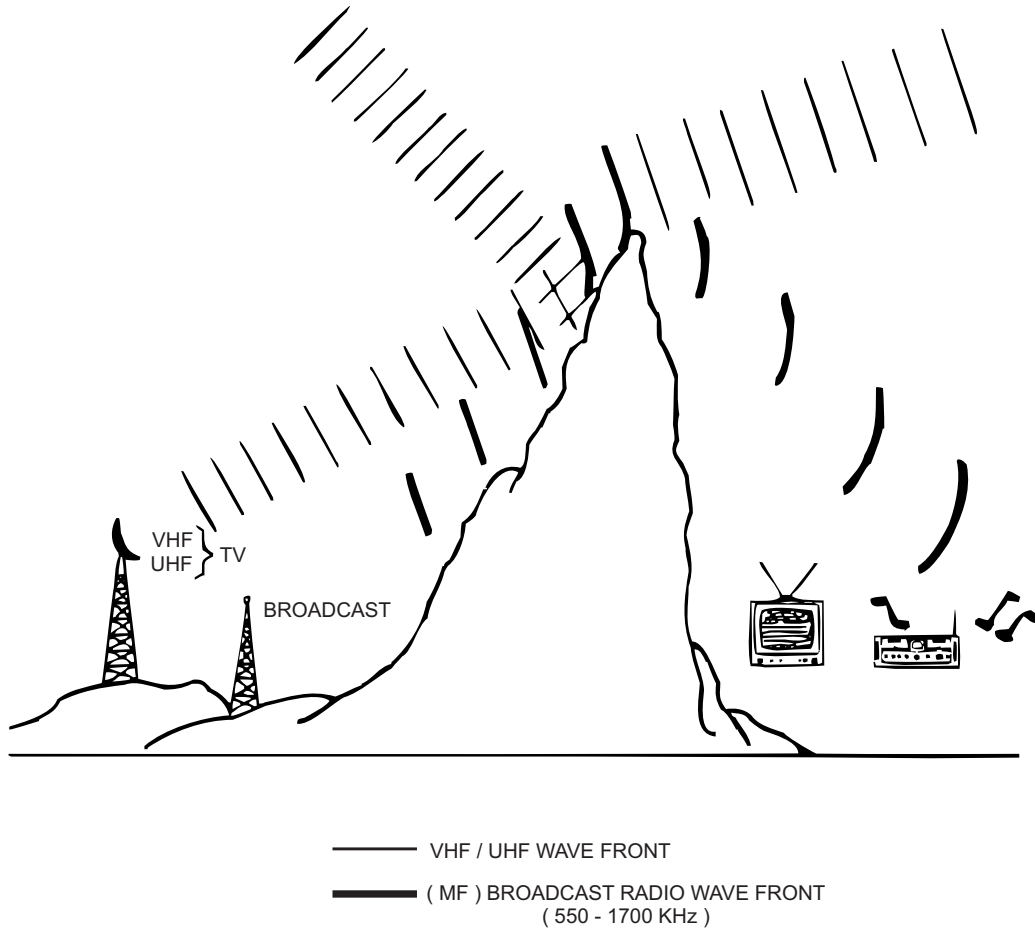

DIFFRACTION  
 Figure 4-10.—Diffraction.

ATF04010

the same space while passing through a given region. Consider two waves of the same frequency traversing the same medium simultaneously. Each particle of the medium is affected by both waves. If the displacement of the particle caused by one wave at any instant is in the same direction as that caused by the other wave, the total displacement of that particle at that instant is the sum of the separate displacements. The resultant displacement is greater than either wave would have caused separately. This effect is called *constructive interference*.

On the other hand, if the displacement effects of the two waves on the particle are in opposite directions, they tend to cancel one another. The resultant displacement of that particle at that instant is the difference of the two separate displacements and is in the direction of the larger wave. The resultant displacement is less than one of the waves would have caused separately. This effect is referred to as *destructive interference*.

If two such opposite displacement effects are equal in magnitude, the resultant displacement is zero.

## DOPPLER EFFECT

The *Doppler effect* is the apparent change in frequency of a wave when a source moves either toward or away from the detector, or when the detector moves toward or away from the sound source.

When there is relative motion between the source of a wave and a detector of that wave, the frequency at the detector position differs from the frequency at the source. If the distance between the source and the detector is decreasing, more wave fronts are encountered per second than when the distance is constant. This results in an apparent increase in the transmitted frequency. Conversely, if the separation is increasing, fewer waves are encountered. There is an apparent decrease in transmitted frequency.

The pitch of the whistle on a fast-moving train sounds higher as the train is coming toward you than when the train is going away. The train's whistle is generating sound waves of constant frequency. The sound waves travel through the air at the same velocity in all directions. As the distance between you and the approaching train decreases, each wave has less distance to travel to reach you than the wave preceding it. The waves arrive with shorter intervals of time between them, and the apparent frequency increases cause the sound to be higher in pitch.

These changes in frequency are called the *Doppler effect*. The Doppler effect affects the operation of equipment used to detect and measure wave energy. The amount of change in the frequency varies directly with the relative velocities of the source and detector, and inversely with the velocity of propagation of the wave within the medium. The Doppler effect is an important consideration when you deal with sonar, radar, target detection, fire control, and navigation equipment.

Q4-21. All types of waves exhibit some common characteristics, such as propagation, reflection, refraction, diffraction and \_\_\_\_\_.

Q4-22. By what process is energy transmitted by the travel of electromagnetic waves or sound waves? \_\_\_\_\_

Q4-23. The \_\_\_\_\_ of propagation is the rate at which the crest of the wave moves.

Q4-24. The frequency of any periodic motion is the number of complete variations or \_\_\_\_\_ per unit of time.

Q4-25. The \_\_\_\_\_ of a wave is the time required to complete a full cycle.

Q4-26. Wavelength depends on the (a) \_\_\_\_\_ of the wave and the (b) \_\_\_\_\_ of propagation of the wave in a given medium.

Q4-27. Energy is transferred in a medium by a disturbance that may have an elastic deformation, a pressure variation, an electric or magnetic intensity, an electric potential, or temperature. Continuous variations induced into a medium are known as \_\_\_\_\_ trains.

Q4-28. Electromagnetic waves are what type of wave? \_\_\_\_\_

Q4-29. In what type of wave does the disturbance take place in the direction of propagation? \_\_\_\_\_

Q4-30. \_\_\_\_\_ waves are produced by two wave trains of the same type and of equal frequency traveling in opposite directions in the same medium.

Q4-31. The law of reflection states, "The angle of incidence is equal to the angle of \_\_\_\_\_."

Q4-32. The angle of refraction depends on the angle of incidence and the \_\_\_\_\_ of refraction.

Q4-33. What term is used to describe the bending of the path of waves around an obstruction?

Q4-34. The \_\_\_\_\_ effect is the apparent change in frequency of a wave when a sound source moves either toward or away from the detector, or when the detector moves either toward or away from the sound source.

and impair vision substantially are called *translucent*. Substances that transmit no light are called *opaque*.

Objects that are not light sources are visible because they reflect part of the light reaching them from some luminous source. If light is neither transmitted nor reflected, it is absorbed or taken up by the medium. When light strikes a substance, some absorption and reflection always takes place. No substance completely transmits, reflects, or absorbs all the light that reaches its surface.

## LIGHT

**LEARNING OBJECTIVES:** Recognize the characteristics of light. Identify colors in the frequency spectrum.

The exact nature of light is not fully understood, although people have been studying the subject for centuries. There are scientific phenomena that are explained only by the wave theory, and other phenomena that are explained by the particle or corpuscular theory. Gradually, physicists have accepted a theory about light that combines these two views; light is a form of electromagnetic radiation. As electromagnetic radiation, light and similar forms of radiation are made up of moving electric and magnetic forces.

## CHARACTERISTICS

Light waves travel in straight lines. When the light waves meet another substance, they are transmitted, reflected, or absorbed. Substances that permit clear vision through them and transmit almost all the light falling upon them are called *transparent*. Substances that allow part of the light to pass but appear clouded

## Luminous Intensity and Intensity of Illumination

*Luminous intensity* refers to the total light produced by a source. *Intensity of illumination* describes the amount of light received per unit area at a distance from the source. The following terms are generally used when luminous intensity and intensity of illumination are described.

**Candlepower.** This is the luminous intensity expressed in candelas. A candela is the luminous intensity in the perpendicular direction of a surface of  $\frac{1}{600,000}$  square meter of a black body at the temperature of freezing platinum under a pressure of 101,325 newtons per square meter.

**Foot-candle.** The intensity of illumination of a surface (illuminance) is directly proportional to the luminous intensity of the light source. Luminous intensity is inversely proportional to the square of the distance between the light source and the surface. Figure 4-11 shows the inverse square law of light.

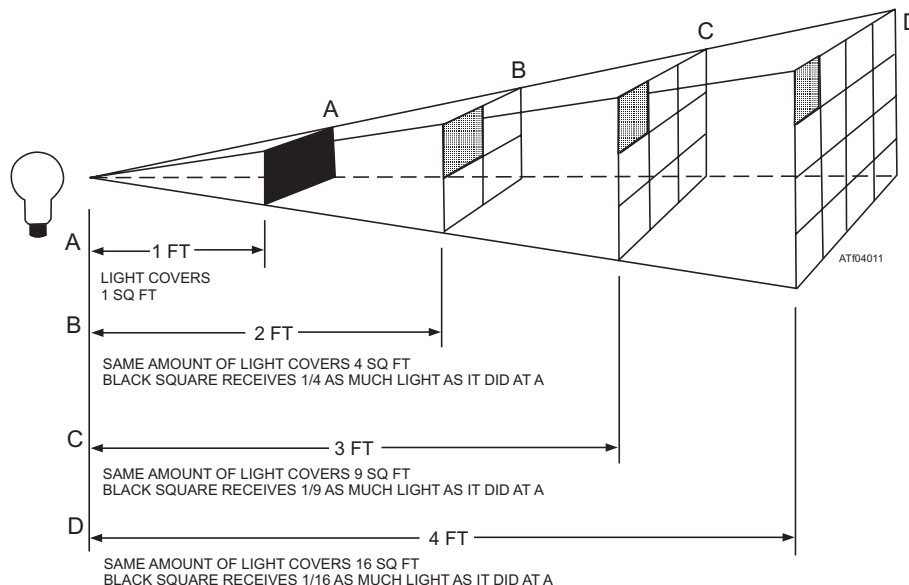

Figure 4-11.—Inverse square law of light.

Place a card 1 foot from a light source. The light striking the card is of a certain intensity. Next, move the card 2 feet away. You can see that the intensity of light decreases with the square of the distance ( $2 \times 2$  or 4 times) and is one-fourth as bright. Now, move the card 3 feet away from the light; the light is now one-ninth as intense as it was when the light was 1 foot from the card. If you move the card 4 feet away from the light source, the light is one-sixteenth as intense.

The foot-candle is one unit of measuring the intensity of incident light using the formula

$$\text{Illumination in foot-candles} = \frac{\text{candlepower of source}}{(\text{distance in feet})^2}$$

A surface 1 foot from a 1-candlepower source has an illumination of 1 foot-candle; but, if the surface is moved to a distance of 4 feet, a 16-candlepower source is required for the same illumination.

The inverse square law of light holds true for undirected light only. For light that is directed, the rate its intensity diminishes depends on the rate of divergence of the beam.

**Lumen.** This unit is the amount of light flowing through a solid angle of 1 radian from a standard candle. The following example helps explain the term lumen. If a light source of 1 candlepower is placed in the center of a sphere with a radius ( $r$ ) of 1 foot, the light source illuminates every point on the surface of the sphere at an intensity of 1 foot-candle. Every square foot of the surface receives 1 lumen of light. The total surface of the sphere is found by the formula  $4 r^2$ . If the radius of a sphere is 1 foot, the area is  $4 \times 3.1416 \times 1^2 = 12.5664$  square feet. Therefore, a source of 1 candlepower emits 12.5664 lumens.

The output of light bulbs is given either in candlepower or in lumens. Since the light bulb may not distribute the light equally in all directions, the lumen is most frequently used. Light bulb manufacturers measure the light output in all directions and specify its total output in lumens. When the total output in lumens is known, the average candlepower is computed by dividing the total output in lumens by 4 (12.5664).

**Lux.** The lux is the illumination given to a surface 1 meter away from a 1-candlepower source and is sometimes called a *meter-candle*.

**Phot.** The phot is the illumination given to a surface 1 centimeter away from a 1-candlepower source and is sometimes called a *centimeter-candle*.

**Luminance.** Luminance (or brightness) refers to the light a surface gives off in the direction of the observer. The lambert is the unit of luminance equal to the uniform luminance of a perfectly diffusing surface that emits or reflects light at the rate of 1 lumen per square centimeter. For a perfectly reflecting and perfectly diffusing surface, the number of lamberts is equal to the number of phots (incident light).

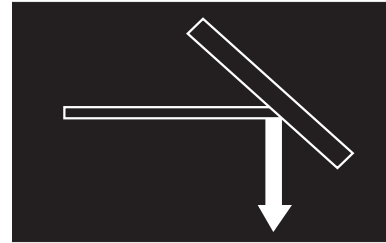

CHANGING DIRECTION  
A

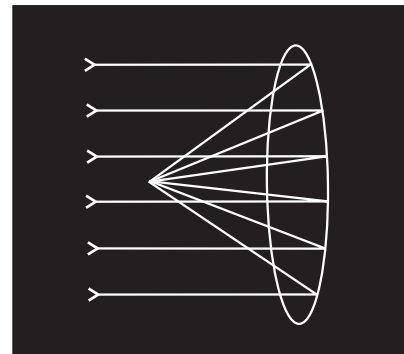

FOCUSING A BEAM  
B

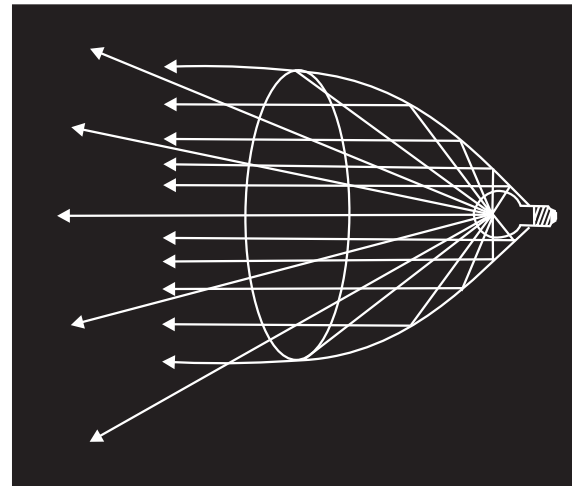

ILLUMINATING AN AREA  
C

AT04012

Figure 4-12.—Reflectors of light.

## Reflection of Light

Light waves obey the law of reflection the same way as other types of waves. Optical devices that reflect light are generally classed as mirrors. Mirrors are a polished opaque surface, or they are a specially coated glass. Glass mirrors refract as well as reflect; however, if the glass is of good quality and not excessively thick, the refraction causes no trouble.

The reflector, figure 4-12, view (A), is used to change the direction of a light beam. Changing the angle at which the incident light impinges upon the mirror changes the angle of the reflected light to a greater or lesser degree.

The reflector is also used to focus a beam of light (fig. 4-12, view (B)). The focusing action of a concave mirror is indicated. The point of focus may be made any convenient distance from the reflector by proper selection of the arc of curvature of the mirror; the sharper the curvature, the shorter the focal length.

The reflector, figure 4-12, view (C), can be used to intensify the illumination of an area. The flashlight is an example of this application. The light source (bulb) is located approximately at the principal focus point, and all rays reflected from the surface are parallel. The reflector does not concentrate all the rays, and some are transmitted without being reflected and are not included in the principal beam.

## Refraction of Light

As light passes through a transparent substance, it travels in a straight line. When light passes into or out of

that substance, it is refracted like other waves. Refraction of light occurs because light travels at different velocities in different transparent media. To make it easier to predict the outcome of specific applications, many transparent substances have been tested for refractive effectiveness. The ratio of the speed of light in air to its speed in each transparent substance is the *index of refraction* for that substance. For example, light travels about one and one-half times as fast in air as it does in glass, so the index of refraction of glass is about 1.5. When the law of refraction is used in connection with light, a denser medium refers to a medium with a higher index of refraction. Refraction through a piece of plate glass is shown in figure 4-13. The ray of light strikes the glass plate at an oblique angle along path AB. If it were to continue in a straight line, it would emerge from the plate at point N. But according to the law of refraction, it is bent toward the normal RS and emerges from the glass at point C. As the light ray enters the air, the ray does not continue on its path, but is bent away from the normal XY, and leaves along the path CD in the air.

If the two surfaces of the glass are parallel, the ray leaving the glass is parallel to the ray entering the glass. The displacement depends upon the thickness of the glass plate, the angle of entry into the glass plate, and the index of refraction for the glass.

All rays striking the glass at any angle other than perpendicular are refracted in the same manner. In the case of a perpendicular ray, no refraction takes place, and the ray continues through the glass and into the air in a straight line, as in the path of ME.

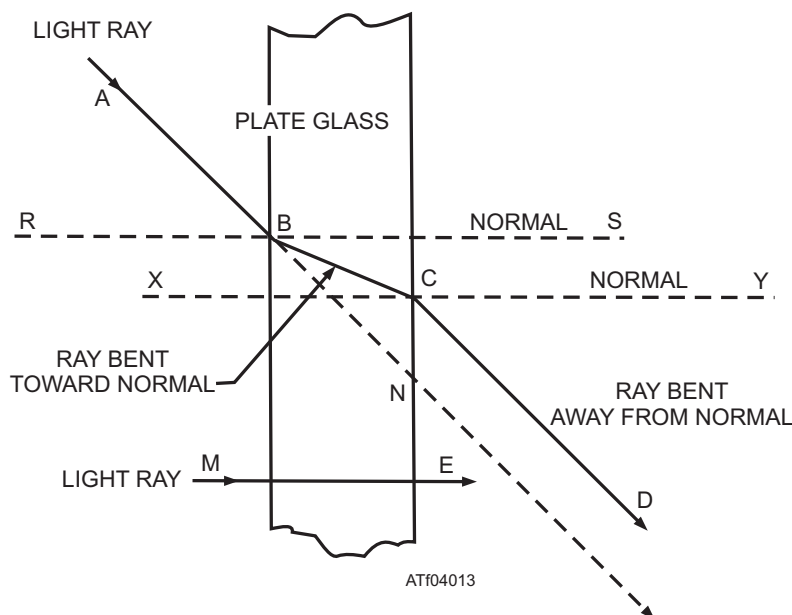

Figure 4-13.—The law of refraction.

**PRISMS.**—When a ray of light passes through a flat sheet of glass, the ray emerges parallel to the incident ray. This is true only when the two surfaces of the glass are parallel. When the two surfaces are not parallel, as in a prism, the ray is refracted differently at each surface of the glass and does not emerge parallel to the incident ray.

In a single prism, figure 4-14, view (A), both refractions are in the same direction. Following the law of refraction, the ray coming out of the prism is not

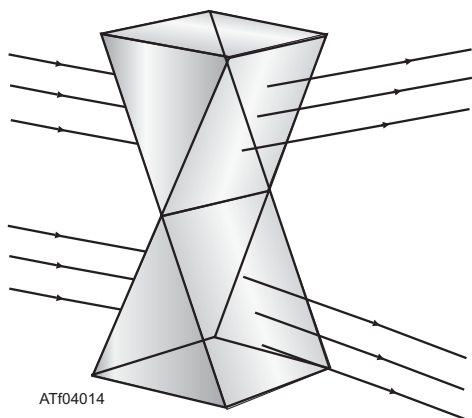
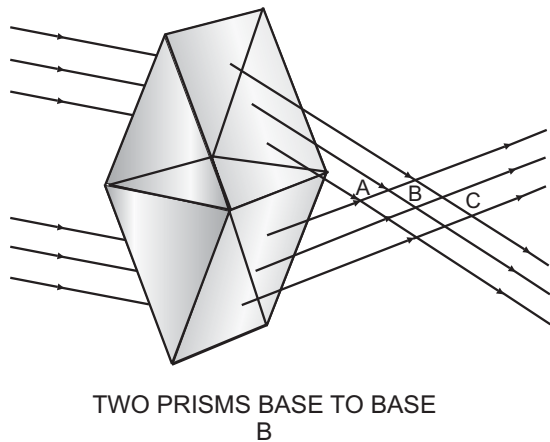
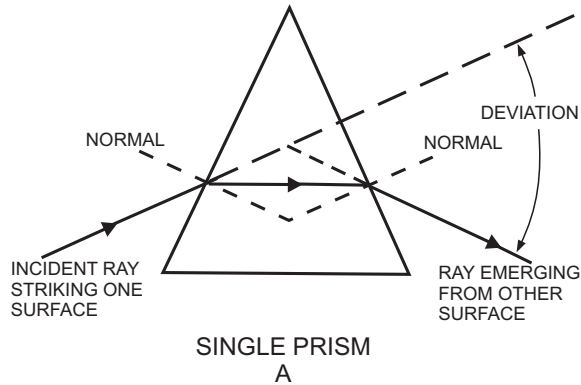
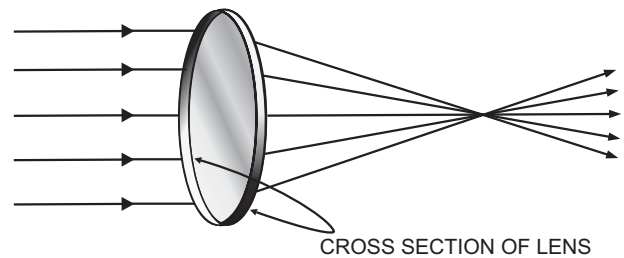

Figure 4-14.—Passage of light through a prism.

parallel to the ray going into it. When the ray entered the prism, it was bent toward the normal; and when it emerged, it was bent away from the normal. You can see that the deviation is the result of the two normals not being parallel.

If two prisms are placed base to base, figure 4-14, view (B), parallel incident rays that pass through them are refracted and intersect. The rays that pass through different parts of the prisms do not intersect at the same point. With two prisms, there are only four refracting surfaces. The light rays from different points on the same plane are not refracted to a point on the same plane behind the prism. The light rays emerge from the prisms and intersect at different points along an extended common baseline, as you can see by looking at points A, B, and C.



FOCUSING ACTION  
A

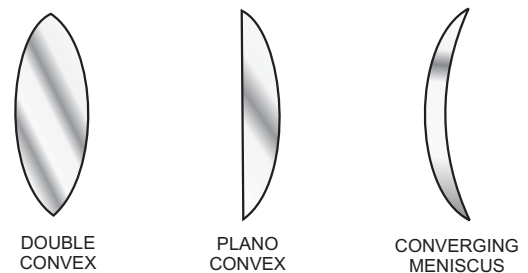
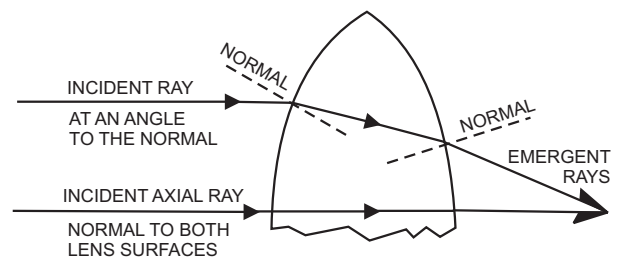

BASIC SHAPES  
C

ATf04015

Figure 4-15.—Positive lenses.

Parallel incident light rays that fall upon two prisms joined apex to apex are spread apart. The upper prism refracts light rays toward its base, and the lower prism refracts light rays toward its base. The two sets of rays diverge in figure 4-14, view (C).

**POSITIVE LENSES.**—A positive (convergent) lens acts like two prisms base to base, with their surfaces rounded off into a curve, as shown in figure 4-15. Rays that strike the upper half of the lens bend downward, and rays that strike the lower half bend upward.

A good lens causes all wavelengths within each ray to cross at the same point behind the lens as in figure 4-15, view (A). When the incident ray of light enters the denser medium (the lens), it bends toward the normal. When the ray passes through the lens into the less dense medium (the air), it bends away from the normal.

Each ray that passes through a positive lens behaves in the same way. All incident light rays, either parallel or slightly diverging, converge to a point after passing through a positive lens.

The only ray of light that can pass through a lens without bending is the ray that strikes the first surface of the lens at a right angle, perpendicular or normal to the surface. The ray passes through that surface without bending and strikes the second surface at the same angle. The ray leaves the lens without bending. This ray is shown in figure 4-15, view (B).

The terms *positive lens* and *convergent lens* are synonymous; either of them may be used to describe the action of a lens that focuses (brings to a point of convergence) all light rays that pass through it. All simple positive lenses are easy to identify since they are thicker in the center than at the edges. The three most common shapes of simple positive lenses are shown in figure 4-15, view (C).

**NEGATIVE LENSES.**—The refraction of negative lens is like the refraction of light rays by two prisms apex to apex. If the prism surfaces were rounded, the result would be a negative (divergent) lens, as seen in figure 4-16. A negative lens is called a *divergent lens*, since it does not focus the rays of light passing through it. Light rays passing through a negative lens diverge or spread apart (fig. 4-16, view (A)).

Look at view (B) of figure 4-16. Here, the law of refraction to a single ray of light passing through a negative lens is shown. However, just as in a positive lens, a ray of light passing through the center of a negative lens is not affected by refraction and passes through without bending.

Three simple negative lenses are shown in figure 4-16, view (C). These lenses often are referred to as concave lenses and are identified by their concave

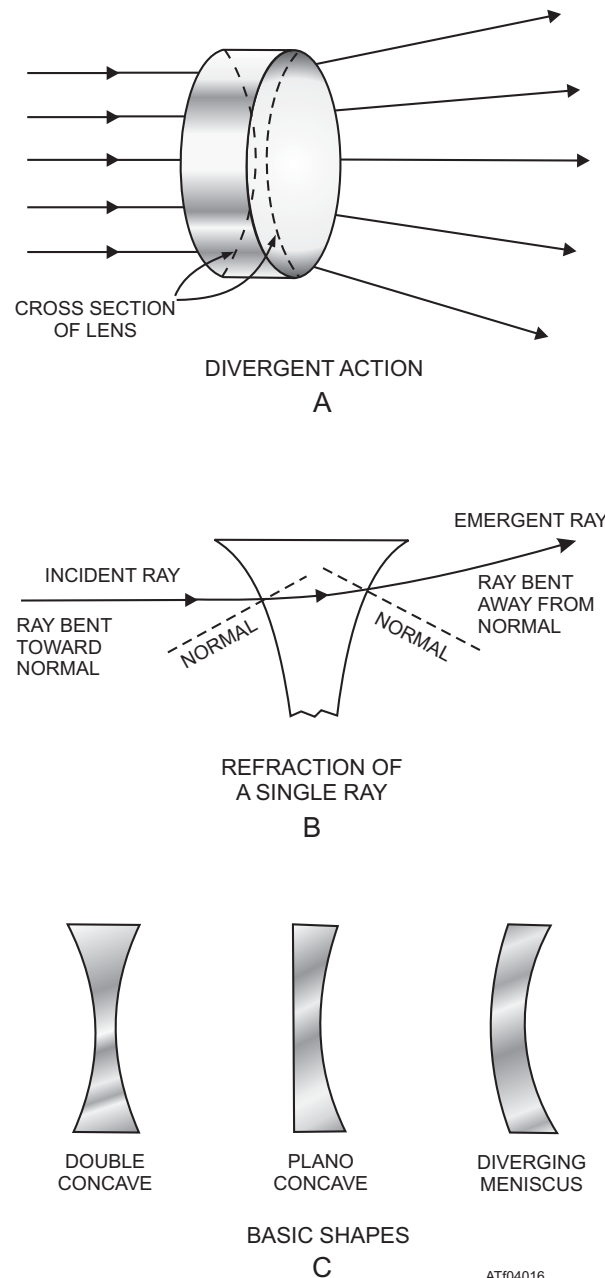

Figure 4-16.—Negative lenses.

surfaces. Simple negative lenses are thicker at the edges than at the center. Negative lenses are generally used in conjunction with simple positive lenses to assist in the formation of a sharper image. Negative lenses eliminate or subdue various defects present in an uncorrected simple positive lens.

## FREQUENCIES AND COLOR

The electromagnetic waves that produce the sensation of light are all very high in frequency and fall between infrared and ultraviolet radiation on the electromagnetic spectrum. This means that waves that

produce the sensation of light have very short wavelengths. These wavelengths are measured in nanometers (billionths of meters, or  $10^{-9}$  meters). By looking at figure 4-17, you can see that light with a wavelength of 700 nanometers is red and that a light with a wavelength of 500 nanometers is blue-green. The information in this figure is based on wavelengths in air, as the color of light depends on its frequency and not its wavelength.

Wavelength varies and depends on the medium the wave is in. When a wave producing the color red is in air, its wavelength is 700 nanometers. When the same wave is in another medium, its wavelength is other than 700 nanometers. When red light that has been traveling in air enters glass, the light loses speed and its wavelength becomes shorter or compressed, but the light continues to be red.

All color-component wavelengths of the visible spectrum are present in equal amounts in white light. Variations in composition of the component wavelengths result in other characteristic colors. For example, when a beam of white light is passed through a prism (fig. 4-17), the beam is refracted and dispersed into its component wavelengths. The eye reacts differently to each of these wavelengths and sees the various colors that make up the visible spectrum. The

visible spectrum is recorded as a mixture of red, orange, yellow, green, blue, indigo, and violet. White light results when the primaries (red, green, and blue) are mixed together in overlapping beams of light.

**NOTE:** These are not the primaries used in mixing pigments.

The complementary or secondary colors (magenta, yellow, and cyan) are shown by mixing any two of the primary colors in overlapping beams of light. For example, red and green light mixed in equal intensities make yellow light; green and blue mixed together produce blue-green (cyan) light; and blue and red light correctly mixed produces magenta (purplish red).

- Q4-35. When light waves meet another substance the waves are either transmitted, refracted, or \_\_\_\_\_.
- Q4-36. Candlepower is the \_\_\_\_\_ intensity expressed in candelas.
- Q4-37. The three principal uses of \_\_\_\_\_ are to change direction of a beam, focus a beam, or to intensify the illumination of an area.
- Q4-38. The ratio of the speed of light in air to its speed in each transparent substance is called the index of \_\_\_\_\_ for that substance.

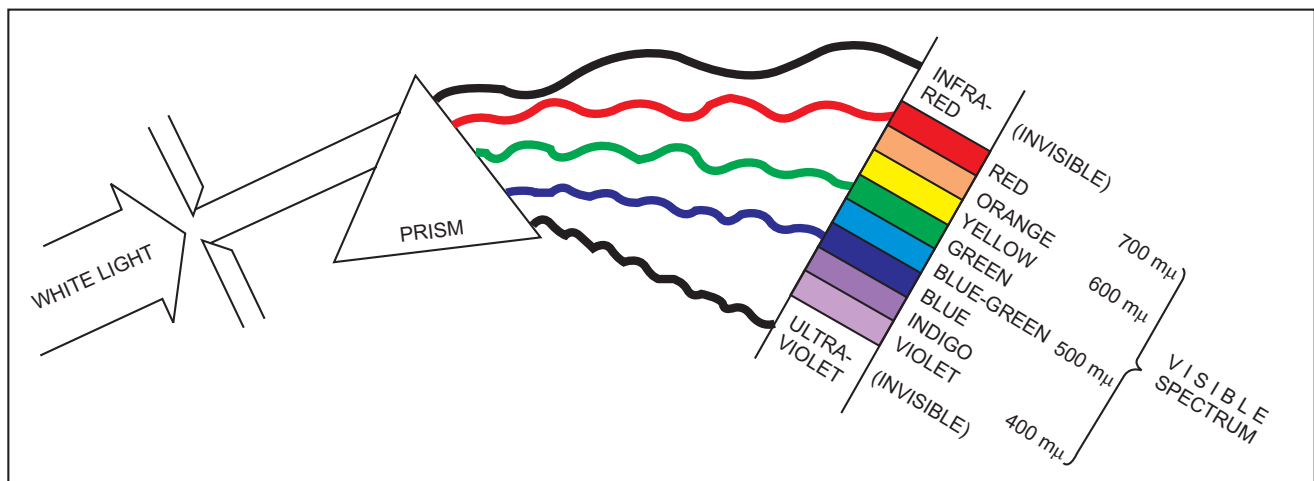

REFRACTION OF LIGHT BY A PRISM. THE LONGEST RAYS ARE INFRARED; THE SHORTEST, ULTRAVIOLET.

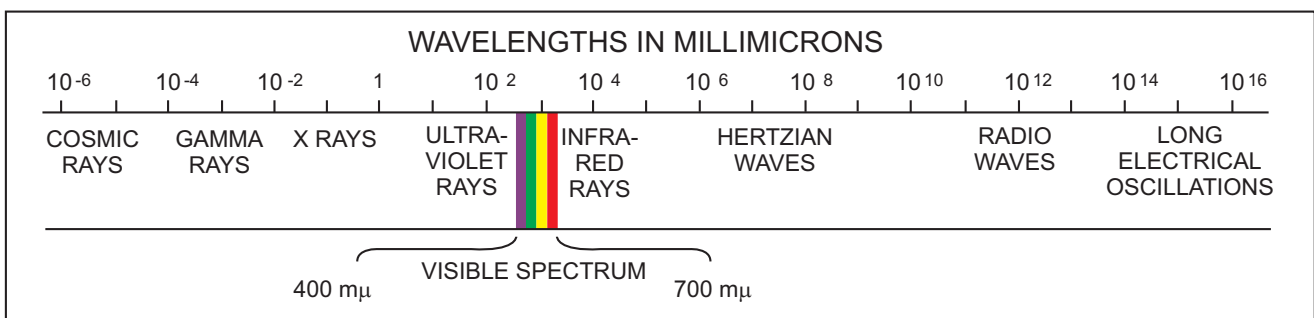

ATf04017

Figure 4-17.—Electromagnetic wavelengths and the refraction of light.



- Q4-39. When a ray of light enters a prism, the ray is bent (a) \_\_\_\_\_ the normal; and when the ray emerges from the prism, it is bent (b) \_\_\_\_\_ from the normal.
- Q4-40. The terms positive lens and \_\_\_\_\_ lens are synonymous; either of them may be used to describe the action of a lens that focuses.
- Q4-41. A negative lens is called a \_\_\_\_\_ lens, since it does not focus the rays of light passing through it.
- Q4-42. The color of light depends on the \_\_\_\_\_ of the light and not on the wavelength.

## SOUND

**LEARNING OBJECTIVES:** Recognize the characteristics of sound generation and propagation. Identify the sound conduction media and recognize its effects on the velocity of sound transmission. Define the terms pitch, tone quality, and the intensity of sound. Identify means of sound measurement, to include intensity level, acoustical pressure, and power. Recognize factors that affect acoustics, to include echo, reverberation, interference, and resonance.

Normally, the term sound refers to hearing. When used in physics, sound refers to a particular type of wave motion. It deals with the generation, propagation, transmission, characteristics, measurement, acoustics, and effects of sound waves.

One example of the generation and propagation of sound waves is the tuning fork. Any object that moves rapidly to and fro or vibrates rapidly and disturbs the surrounding medium may become a sound source. Sound requires three components—a source, a medium for transmission, and a detector. As widely different as sound sources may be, the waves these sources produce have certain basic characteristics.

### SOUND TRANSMISSION

Sound waves are longitudinal-type waves that rely on a medium for propagation and transmission. They are produced by the initiation of a succession of compressions and rarefactions in a medium capable of transmitting these vibrational disturbances. Particles of matter in the medium acquire energy from the vibrating source and enter the vibrational mode themselves. The wave energy produced is passed along to adjacent particles as the periodic waves travel through the

medium. Vibrating elements such as tuning forks previously discussed, or reeds (saxophone, clarinet), strings (vocal cords, guitar) membranes (loudspeaker, drum) are some examples of the initiation of sound waves. Sound waves are transmitted outward from their source by the surrounding air, the most common transmitting medium. When they enter the ear, they produce the sensation of sound.

At low altitudes, hearing sounds is usually not difficult. At higher altitudes, the density of air is lower, and in turn less energy may be transferred from the source to the air. Dense air is a more efficient transmitter than thin air.

The major differences between sound, heat, and light waves are the frequencies, the nature of the waves, and the velocities of wave travel.

### CONDUCTION MEDIA AND SPEED OF TRANSMISSION

In a uniform medium under given physical conditions, sound travels at a definite speed. In some substances, the speed of sound is higher than in others. Even in the same medium, when temperature conditions differ, the speed of sound varies. The speed of sound in air is 331.5 meters per second (m/s) at 0°C and 346 m/s at 25 °C. This speed will increase with temperature at approximately 0.6 m/s for every °C of temperature rise.

The speed of sound in water is approximately 4 times as fast as in air, in water at 25°C sound travels at nearly 1,500 m/s. In some solids the speed of sound is even greater. In a steel rod, for example, sound travels at approximately 5,200 m/s, which is 15 times the speed in air. Generally, the speed of sound varies with the temperature of the transmitting medium. For gases the change in speed is rather large. For liquids and solids, however, the change in speed is rather small. Values for the speed of sound waves in various media are given in table 4-3.

Table 4-3.—Comparison of Speed of Sound in Various Media

SPEED OF SOUND (25°C)	
Medium	Speed (m/s)
Air	346
Hydrogen	1,339
Alcohol	1,207
Water	1,497
Glass	4,540
Aluminum	5,000
Iron (steel)	5,200

## CHARACTERISTICS OF SOUND

Many words describe sounds, such as whistle, scream, rumble, and hum. Most of these words describe noises, not musical tones. Musical tones are based on the regularity of the vibrations, the degree of damping, and the ability of the ear to recognize components that have a musical sequence.

Sound has three characteristics: pitch, quality, and intensity. Each of these characteristics is associated with one of the properties of the vibrating source or of the waves that the source produces. The ear can distinguish tones that are different in each of these characteristics.

- The number of vibrations per second determines its pitch.
- The number of overtones (harmonics) that the wave contains determines its quality.
- The amplitude of the wave motion determines its intensity.

### Pitch

The term *pitch* describes the frequency of a sound. The recognizable difference between the tones produced by two different keys on a piano is a difference in pitch. The pitch of a sound is proportional to the number of compressions and rarefactions received per second, which, in turn, is determined by the vibration frequency of the sounding source. Sound waves vary in length; a long wavelength sounds as if its pitch is low, while a short wavelength sounds as if its pitch is high.

Pitch is usually measured by comparison with a standard. The standard tone may be produced by a tuning fork of known frequency or by a siren whose frequency is computed for a particular speed of rotation. When the speed is regulated, the pitch of the siren is made equal to that of the tone being measured. If the two sources are sounded alternately, the ear can determine this equality directly. The ear also can determine this equality directly by the elimination of beats by regulating the speed of the siren if the two sources are sounded together.

**NOTE:** The human ear does not hear sounds below 15 Hz or above 20,000 Hz. The frequency range over which the human ear hears sound is known as the audible range, and the sounds that the ears hear are known as sonic. Sounds below 15 Hz are known as

subsonic. Sounds above 20,000 Hz are known as ultrasonic.

On the musical scale, pitch refers to the standard frequency of a given note on the scale. In a few cases, 256 Hz is used for the keynote, sometimes called middle C. For scientific purposes, the A string of the violin is tuned to 440 Hz. The note one octave higher than the first has a frequency twice that of the first, and one an octave lower is one-half the frequency of the first. For example, if middle C on a piano is tuned to 256 Hz, the C an octave higher is 512 Hz, and one octave lower is 128 Hz. A pitch change from 55 Hz to 110 Hz is of just as much consequence as the change from 440 Hz to 880 Hz.

### Tone Quality

Most sounds and musical notes are not pure tones but are mixtures of tones of different frequencies. The tones produced by most sources are composite waves in which the sound of lowest pitch (the fundamental tone) is accompanied by several harmonics or overtones. These harmonics have frequencies that are two, three, four, or more times that of the fundamental frequency. The quality of a tone depends on the number of overtones present and on their frequencies and intensities relative to the fundamental tone. The difference in quality is the characteristic that distinguishes tones of like pitch and intensity when the tones are sounded on different types of musical instruments (piano, organ, violin, and so forth).

### Intensity

The intensity of sound, at a given distance, depends upon the amplitude of the waves. When a bell rings, the sound waves spread out in all directions, and the sound is heard in all directions. When a bell is struck lightly, the vibrations are of small amplitude, and the sound is weak. A stronger blow produces vibrations of greater amplitude, and the sound is louder. Therefore, the amplitude of the air vibrations is greater when the amplitude of the vibrations of the source is increased, and the loudness of the sound depends on the amplitude of the vibrations of the sound waves. As the distance from the source increases, the energy in each wave spreads out, and the sound becomes weaker.

The intensity of sound is the energy per unit area per second. In a sound wave of simple harmonic motion, the energy is half kinetic and half potential. Half of the energy is due to the speed of the particles. The other half of the energy is due to the compression

and rarefaction of the medium. These two energies are 90 degrees out of phase at any instant; that is, when the speed of particle motion is at a maximum, the pressure is normal. When the pressure is at a maximum or a minimum, the speed of the particles is zero.

Loudness is a subjective measurement that depends primarily on the sound pressure, frequency, and waveform of the stimulus. Intensity of sound is an objective measurement of the sound power being delivered. Intensity is usually measured as the power flowing through a unit area perpendicular to the direction of the waves. One such method specifies microwatts flowing through an area of 1 square centimeter. One microwatt is equivalent to 10 ergs per second or  $10^{-6}$  joules per second.

At any distance from a point source of sound, the intensity of the wave varies inversely as the square of the distance from the source. As a sound wave advances, variations in pressure occur at all points in the transmitting medium. The greater the pressure variations, the more intense the sound wave. Intensity is proportional to the square of the pressure variation, regardless of frequency. When pressure changes are measured, intensities of sounds that have different frequencies can be compared directly.

### MEASUREMENT OF SOUND

Measurement of sound takes into consideration the sound units, intensity level, acoustical pressure, and power ratios.

The range of sound that the human ear can detect varies with the individual. The normal range extends from about 20 to 20,000 vibrations per second. In the faintest audible speech sounds, the intensity at the ear is about  $10^{-16}$  watts/centimeter (cm)<sup>2</sup>. At the threshold of feeling, the maximum intensity that the ear perceives as sound is about  $10^{-4}$  watts/cm<sup>2</sup>.

The human ear is a nonlinear unit that functions logarithmically. Its threshold of audibility is reached when intensity is reduced to such a low level that auditory sensation ceases. On the other hand, the threshold of feeling is reached when intensity is increased to such a high level that sound produces the sensation of feeling and becomes painful. By applying this procedure over a wide frequency range, data is used to plot two curves—one for the lower limit of audibility and the other for the maximum auditory response (fig. 4-18). Below the lower curve, the human ear cannot hear the sound. Above the upper curve, the sensation is one of feeling rather than of hearing; that is, the

sensation of sound is masked by pain. The area between the two curves shows the pressure ranges for auditory response at various frequencies.

### Sound Units

The same type of scale that is used to measure length does not measure sound. Units of sound measurement vary logarithmically with the amplitude of the sound variations. These units are the bel and decibel (dB), which refer to the difference between sounds of unequal intensity or sound levels. The *decibel* (one-tenth of a bel) is the minimum change of sound level perceptible to the human ear. A sound for which the power is 10 times as great as that of another sound level differs in power level by 1 bel, or 10 dB. For example, 5 dB may represent almost any volume of sound, depending on the intensity of the reference level on which the ratio is based.

In sound-system engineering, decibels are used to express the ratio between electrical powers or between acoustical powers. If the amounts of power to be compared are  $P_1$  and  $P_2$ , the ratio in decibels is

$$\text{dB} = 10 \times \log \frac{(P_2)}{(P_1)}$$

**NOTE:** When the logarithmic base is not indicated, the base is assumed to be 10.

If  $P_2$  is greater than  $P_1$ , the decibel value is positive and represents a gain in power. If  $P_2$  is less than  $P_1$ , the decibel value is negative and represents a loss in power.

### Intensity Level

An arbitrary zero reference level is used as a reference point to describe the loudness of sound. This

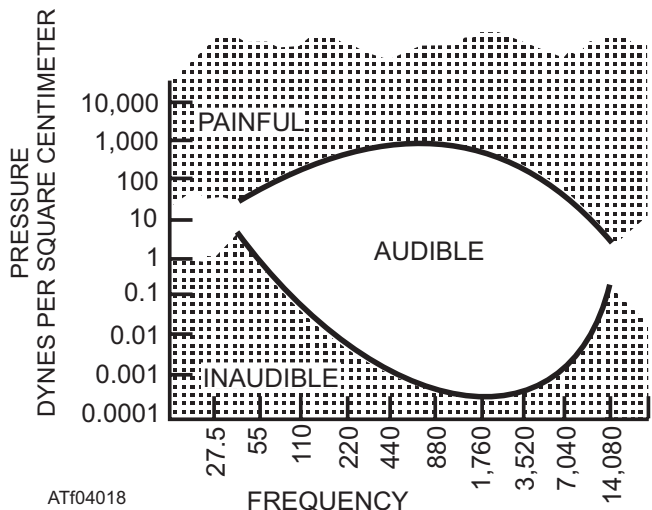

Figure 4-18.—Field of audibility.

zero reference level is the sound produced by  $10^{-16}$  watts per square centimeter of surface area facing the source. This level approximates the least sound perceptible to the ear and is called the *threshold of audibility*. The sensation experienced by the ear when the ear is subjected to a noise of 40 dB above the reference level would be 10,000 times as great as when subjected to a sound that is barely perceptible.

### Acoustical Pressure

Typical values of sound levels in decibels and the corresponding intensity levels are summarized in table 4-4. The values in this table are based on an arbitrarily chosen zero reference level. Note that for each tenfold increase in power, the intensity of the sound increases 10 dB. The power intensity doubles for each 3-dB rise in sound intensity.

Table 4-4.—Values of Sound Levels

SOUND LEVEL (DECIBELS)	INTENSITY LEVEL (WATTS/CM <sup>2</sup> )
0	$10^{-16}$
40	$10^{-12}$
60	$10^{-10}$
80	$10^{-8}$
100	$10^{-6}$
110	$10^{-5}$
120	$10^{-4}$
130	$10^{-3}$

### Power Ratio

The decibel is used to express an electrical power ratio, such as amplifier gain, microphone output, or the power in a circuit compared to an arbitrarily chosen reference power level. The value of decibels is often computed from the voltage ratio or the current ratio squared. These values are proportional to the power ratio for equal values of resistance. If the resistances are not equal, a correction must be made. To find the number of decibels from the voltage ( $E$ ) ratio, assume that the resistances are equal and substitute  $E^2$  for  $P$  in the basic acoustical power equation:

$$\text{dB} = 10 \times \log \frac{E_2^2}{E_1^2} = 10 \times \log \left( \frac{E_2}{E_1} \right)^2$$

or

$$\text{dB} = 20 \times \log \frac{E_2}{E_1}$$

To find the number of decibels from the current ( $I$ ) ratio, assuming that the resistances are equal, substitute  $I^2$  for  $P$  in the basic equation:

$$\text{dB} = 10 \times \log \left( \frac{I_2}{I_1} \right)^2$$

or

$$\text{dB} = 20 \times \log \frac{I_2}{I_1}$$

The power level of an electrical signal is often expressed in decibels above or below a 0.001-watt (1 milliwatt) power level:

$$\text{dBm} = 10 \times \log \left( \frac{P}{0.001} \right)$$

where dBm is the power level above 1 milliwatt in decibels, and  $P$  is the power in watts.

The volume level of an electrical signal comprising speech, music, or other complex tones is measured by a specially calibrated voltmeter called a *volume indicator*. The volume levels read with this indicator are read in v units (vu), the number being numerically equal to the number of decibels above or below the reference volume level. Zero vu represents a power of 1 milliwatt dissipated in an arbitrarily chosen load resistance of 600 ohms, which corresponds to a voltage of 0.7746 volt. Therefore, when the vu meter is connected to a 600-ohm load, vu readings in decibels are used as a direct measure of power above or below 1 milliwatt. For any other value of resistance, the following correction must be added to the vu reading to obtain the correct vu value:

$$\text{vu} = \text{vu reading} + 10 \times \log \frac{600}{R}$$

where vu is the actual volume level, and  $R$  is the actual load, or resistance, across which the vu measurement is made.

**NOTE:** If the volume levels are indicated in units other than vu, the meter calibration, or reference level, must be stated with the decibel value.

## ACOUSTICS

Acoustics is the science of sound, including its propagation, transmission, and effect. The performance of an announcing system or sound system when the system is used in a room or enclosed space depends on the acoustical characteristics of the enclosure. Sound originating in an enclosed space is partly reflected and partly absorbed by enclosing surfaces, such as walls, ceilings, and floors. This action introduces echoes, reverberations, interference, and resonance, which may seriously impair the quality or character of the sound.

### Echo

Light is often thought of first whenever reflection is discussed; however, reflection is equally common in other waves. An echo is the repetition of a sound caused by the reflections of sound waves. For example, when a surface of a large room reflects sound, the reflected sound appears as a distinct echo and is heard an appreciable interval later than the direct sound. A concave surface may focus the reflected sound energy at one locality. Such a reflection may be several levels higher in intensity than the direct sound, and its arrival at a later time may be particularly disturbing. This condition is corrected with one or more of the following techniques:

- Covering the offending surface with absorbing material to reduce the intensity of the reflected sound
- Changing the contour of the offending surface, thus sending the reflected sound in another direction
- Changing the position of the loudspeaker
- Varying the amplitude or the pitch of the signal

### Reverberation

Reverberation is the persistence of sound due to the multiple reflection of sound waves between several surfaces of an enclosure. Reverberation is one of the most common acoustical defects of a large enclosure. Its duration varies directly with the time interval between reflections (the size of the enclosure) and inversely with the absorbing efficiency of the reflecting surfaces. The result is an overlapping of the original sound and its images. If excessive, reverberation causes confusion and makes speech unintelligible.

The hangar deck of an aircraft carrier is an example of an extremely reverberant area. The volume is large, and the hard steel interior surfaces offer very little absorption. If a single loudspeaker is mounted in a hangar deck, you can understand speech when you are standing directly in front of the loudspeaker. As you move away from the loudspeaker or if you move in a direction that increases the angle between you and the loudspeaker's sound axis, intelligibility decreases rapidly. Sound from a loudspeaker in a reverberant space (such as a hangar deck) is composed of direct sound that reaches the listener without any reflection and indirect sound that is received with at least one reflection.

Intelligibility, under these conditions, is related to the ratio of direct sound to indirect sound. As the listener moves away from the loudspeaker, the ratio of direct sound to indirect sound at the listener's position decreases, and intelligibility decreases correspondingly. In a highly reverberant space, intelligibility decreases with distance from the loudspeaker.

To prevent sound from becoming unintelligible in a highly reverberant space, install several speakers in an area. The power requirements remain the same; one 25-watt speaker is replaced by five 5-watt speakers, each consuming 5 watts. This would greatly increase the direct-to-indirect sound ratio.

### Interference

Any disturbance, man-made or natural, that causes an undesirable response or the degradation of a wave is referred to as interference.

Two sound waves that move through the same medium at the same time advance independently. Each sound wave produces the same disturbance as if it were alone. The resultant of the two waves is obtained by adding the ordinates (instantaneous magnitudes) of the component waves algebraically.

Two sound waves of the same frequency in phase with each other that move in the same direction are additive. The resultant wave is in phase with, and has an amplitude equal to, the sum of the component waves.

Two sound waves of the same frequency in phase opposition that move in the same direction are subtractive. If the component waves have equal amplitudes, the resultant wave is zero. This addition or subtraction of waves is often called *interference*.

Two sound waves of slightly different frequency that move in the same direction produce a beat note. For example, two waves originate from two vibrating sources at the same point, and the frequency of one wave is one vibration per second greater than the other one at a particular instant. The sources produce additive disturbances at some points and subtractive disturbances at other points on the relative positions of the waves. These changes continue as long as the sources are kept vibrating. The resultant wave has a periodic variation in intensity at a frequency equal to the difference between the original frequencies of the component waves. The difference frequency, referred to as the beat frequency, produces a type of pulsating interference particularly noticeable in sound waves. The effect of beat frequency (beats) produces alternately loud and soft pulses or throbs. The effect is most pronounced when the component waves have equal amplitudes.

### Resonance

Resonance, or sympathetic vibration, is a common problem encountered in acoustics. Resonance is more serious than some other problems because the possibility exists for damage to equipment. Reverberation and resonance are frequently confused but are distinctly different in nature. Reverberation is a result of the reflection of sound waves and of the interaction between the direct and reflected sound. Only a single source is involved. In resonance, however, the offending object becomes a sound source under certain conditions. For example, if you've ever put your head into an empty barrel or other cavity and made noises varying in pitch, you'll have seen that when your voice reached a certain pitch, the tone produced seemed much louder than did the others. The reason for this phenomenon is that at that a certain pitch, the frequency of vibrations of the voice matched the resonant (or natural) frequency of the cavity. The resonant frequency of a cavity is the frequency at which the cavity body will begin to vibrate and create sound waves. When the resonant frequency of the cavity was reached, the sound of the voice was reinforced by the sound waves created by the cavity and resulted in a louder tone.

Another common example of resonance is found in a crystal oscillator circuit. When an alternating voltage is applied to a crystal that has the same mechanical (resonant) frequency as the applied voltage, the crystal vibrates, and only a small applied voltage is needed to sustain vibration. In turn, the crystal generates a relatively large voltage at its resonant frequency.

- Q4-43. The three components that are required by sound are source, medium, and \_\_\_\_\_.
- Q4-44. Sound waves are transmitted by the compression and \_\_\_\_\_ of particles of matter in the medium.
- Q4-45. The three characteristics of sound are pitch, intensity, and \_\_\_\_\_.
- Q4-46. The term pitch describes the \_\_\_\_\_ of a sound wave.
- Q4-47. Tone \_\_\_\_\_ is the characteristic that distinguishes tones of like pitch and intensity.
- Q4-48. The intensity of sound, at a given distance, depends upon the \_\_\_\_\_ of the waves.
- Q4-49. The range of sound that the human ear can detect varies with the individual. The normal range extends from about 20 to \_\_\_\_\_ vibrations per second.
- Q4-50. The \_\_\_\_\_ is the minimum change of sound level perceptible to the human ear.
- Q4-51. The least sound perceptible to the ear is usually called the \_\_\_\_\_ of audibility.
- Q4-52. For each tenfold increase in power, the intensity of the sound increases \_\_\_\_\_ decibels.
- Q4-53. The volume level of an electrical signal comprising speech, music, or other complex tones is measured by a specially calibrated voltmeter called a \_\_\_\_\_ meter.
- Q4-54. The performance of an announcing system or sound system, when the system is used in a room or enclosed space, depends on the \_\_\_\_\_ characteristics of the enclosure.
- Q4-55. A(n) \_\_\_\_\_ is the repetition of a sound caused by the reflection of sound waves.
- Q4-56. The result of the original sound being overlapped with its reflected images is known as \_\_\_\_\_.
- Q4-57. Any man-made or natural disturbance that causes an undesirable response or the degradation of a wave is referred to as \_\_\_\_\_.
- Q4-58. The (a) \_\_\_\_\_ frequency of a cavity is the frequency at which the cavity body will begin to vibrate and create a(n) (b) \_\_\_\_\_ wave.

## CHAPTER 4

# ANSWERS TO REVIEW QUESTIONS

- A4-1. *Radiation*  
A4-2. *Radiation*  
A4-3. *Conductivity*  
A4-4. *Convection*  
A4-5. *Electromagnetic*  
A4-6. *Black*  
A4-7. *Kelvin*  
A4-8. *(a) 212, (b) 32*  
A4-9. *86*  
A4-10. *(a) Absolute, (b) Celsius*  
A4-11. *Fahrenheit*  
A4-12. *Linear*  
A4-13. *Thermometry*  
A4-14. *1*  
A4-15. *Resistance*  
A4-16. *Btu (British thermal unit)*  
A4-17. *252*  
A4-18. *Specific*  
A4-19. *Fusion*  
A4-20. *Five*  
A4-21. *Absorption*  
A4-22. *Propagation*  
A4-23. *Velocity*  
A4-24. *Cycles*  
A4-25. *Period*  
A4-26. *(a) Frequency, (b) velocity*  
A4-27. *Wave*  
A4-28. *Transverse*  
A4-29. *Longitudinal*  
A4-30. *Standing waves*  
A4-31. *Reflection*  
A4-32. *Index*  
A4-33. *Diffraction*  
A4-34. *Doppler*  
A4-35. *Absorbed*  
A4-36. *Luminous*  
A4-37. *Reflectors/mirrors*  
A4-38. *Refraction*  
A4-39. *(a) Toward, (b) away*  
A4-40. *Convergent*  
A4-41. *Divergent*  
A4-42. *Frequency*  
A4-43. *Detector*  
A4-44. *Rarefaction*  
A4-45. *Quality*  
A4-46. *Frequency*  
A4-47. *Quality*  
A4-48. *Amplitude*  
A4-49. *20,000*  
A4-50. *Decibel (dB)*  
A4-51. *Threshold*  
A4-52. *10*  
A4-53. *Vu*  
A4-54. *Acoustical*  
A4-55. *Echo*  
A4-56. *Reverberation*  
A4-57. *Interference*  
A4-58. *(a) Resonant, (b) sound*





## CHAPTER 5

# MAINTENANCE AND TROUBLESHOOTING

Aircraft and avionics systems must be in top operating condition to ensure completion of their mission. The effectiveness of avionics systems depends on the technician's ability to maintain them. You are only as good as the tools and publications you use and as your knowledge of general and specific maintenance procedures. This chapter covers safety, general maintenance procedures, wiring, hardware, printed circuits, and electrostatic discharge.

### SAFETY

**LEARNING OBJECTIVES:** Identify safety precautions regarding aircraft, personnel, material, and tools. Identify the classes of fire and procedures for extinguishing electrical fires. Identify the dangers of compressed air. Identify the dangers of volatile fluids.

A technician will install, maintain, and repair electrical and electronic equipment in confined spaces where dangerously high voltages are present. Among the hazards of this work are injury caused by electric shock, electrical fires, harmful gases, and misused compressed air. Also, you must include improper use of tools among these hazards. Using common sense and carefully following established rules will help produce an accident-free career.

When working, there is one rule to stress strongly—**SAFETY FIRST**. Whether you are working in the shop, on the flight line, or during a flight, you should follow prescribed safety procedures. When you are working on or near aircraft there is the danger of jet blast or of losing your balance or being struck by propeller or rotor blades.

Because of these dangers, you need to develop safe and intelligent work habits. You should become a safety specialist, trained in recognizing and correcting dangerous conditions and unsafe acts. Safety is the responsibility of all hands.

### GENERAL PRECAUTIONS

Because of the chance of injury, the danger of fire, and possible material damage, only authorized personnel can repair and maintain electronic and

electrical equipment. Some general guidelines for personnel to follow are:

- Make sure you get a thorough safety indoctrination from your supervisor.
- Report a condition that you believe to be unsafe to your supervisor.
- Warn others of an unsafe condition or practice.
- Wear personal protective equipment (PPE) as required.
- Report all injury and illness immediately.
- Administer first aid as required.
- **DO NOT TAKE AN UNNECESSARY RISK.**
- Follow each safety precaution carefully.

Cooperation and vigilance of personnel will prevent most accidents that occur in non-combat operations. The following is a list of general, common sense safety precautions. Memorize and observe them.

- **NEVER WORK ALONE.** Always work in the presence of another person capable of rendering aid in an emergency (to de-energize equipment or render first aid in case of injury due to electrical shock).
- Do not wear loose-fitting clothing while working with mechanical equipment.
- Remove all rings, watches, and other metal jewelry prior to working with electrical and electronic equipment.
- Ensure all equipment is properly grounded and correct power requirements are satisfied.
- Become familiar with the equipment.

You must know how to treat burns and how to give artificial respiration to a person suffering from electric shock. In some cases, you may have to perform external heart compression along with artificial ventilation, known as cardiopulmonary resuscitation (CPR). To be qualified to perform CPR, you must take the certified CPR training course. Personal CPR training is available at many Navy medical facilities. It is important to keep

your CPR up to date by requalifying in the required time frame. The life of a shipmate could easily depend upon your CPR skills. This is not to say that knowledge of other first aid procedures is less important. You also are responsible for getting first aid training.

**WARNING**

Do not perform CPR unless you have had proper training.

The two safety-related publications with which you should be familiar are *Navy Occupational Safety and Health (NAVOSH)*, OPNAVINST 5100.23, and *Navy Safety Precautions for Forces Afloat*, OPNAVINST 5100.19. These publications deal with a variety of operations; therefore, they are basic and general in nature. An activity refers to these instructions when it

establishes specific safety instructions for its particular equipment, weapons system, or locality.

**Precautions Regarding Aircraft**

As a technician, you are exposed to flight line hazards. You will be working around moving equipment and aircraft, which is dangerous; therefore, you need to be alert. Always follow your activity's instruction on the application of external power. The maintenance instruction manual (MIM) for each type of aircraft has an illustration of danger areas, such as that for the F/A-18 aircraft shown in figure 5-1. Study the illustration for each aircraft in your operating area. Most safety instructions require the anti-collision light to be operating whenever the engine or engines are operating. This gives an additional warning so you will be aware of propellers, rotors, or intakes and exhausts.

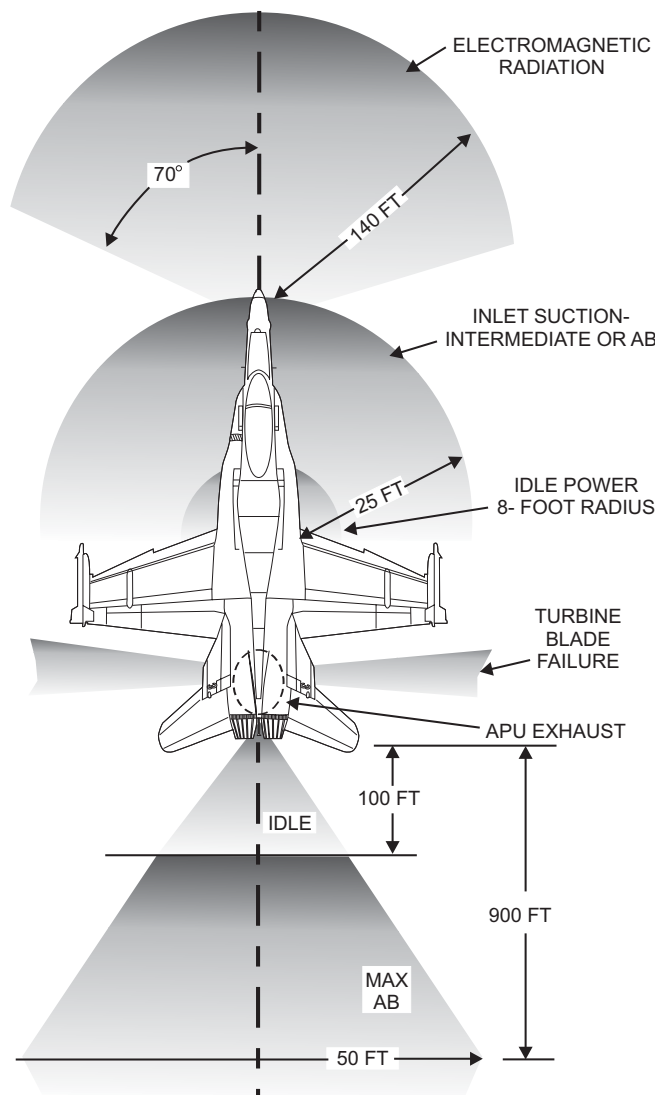

AEf05001

Figure 5-1.—Radiation, intake, exhaust, and turbine blade failure danger areas.

## Precautions Regarding Material and Personnel

When repairs on operating equipment are necessary, only experienced personnel under supervision should do the work. If possible, repairs should be made on de-energized circuits. When working on electrical equipment, take the following actions:

- Open and tag the main supply switches or cut-out switches. The tag should read as follows: “This circuit is open for repairs and shall not be closed except by direct order of \_\_\_\_\_ (usually the person directly in charge of the repairs).”
- Securely cover fuse boxes and junction boxes except when working on them.
- Remove and replace fuses only after the circuit is de-energized. If a fuse blows, replace it with a fuse of the same current rating only. When possible, carefully check the circuit before making the replacement, since a burned-out fuse often results from a circuit fault.
- Move slowly when working around electrical equipment and maintain good balance.
- Make sure there is enough light for good illumination.
- Make sure there is insulation for ground by using a suitable non-conducting material.

Heed the following cautions:

- DO NOT alter or disconnect safety devices, such as interlocks, overload relays, and fuses except when replacing them.
- DO NOT change or modify safety or protective devices in any way without authorization.
- DO NOT lunge after falling tools.
- DO NOT work on electrical equipment if you are mentally or physically exhausted.
- DO NOT touch energized electrical equipment when standing on metal, damp, or other well-grounded surfaces.
- DO NOT handle energized electrical equipment when wet or perspiring heavily.

**HIGH-VOLTAGE PRECAUTIONS.**—Never work alone near high-voltage equipment. Never measure voltages in excess of 300 volts by probing or holding the test probe in your bare hands. When

measurements are necessary on equipment that has a potential in excess of 300 volts, wear rubber gloves if possible. Where rubber gloves cannot be worn, observe the following precautions and procedures:

1. First de-energize the equipment (or circuit).
2. Discharge high-voltage capacitors with a suitable shorting probe.
3. Attach test leads capable of measuring high-voltage to the desired test points.
4. Have an assistant who is standing by energize the power source for the equipment. Then take the measurement.
5. Have the equipment de-energized prior to removing test leads after you have taken the measurement.

**LOW-VOLTAGE PRECAUTIONS.**—Most people never realize the dangers of low-voltage electric shock. Current rather than voltage is the criterion for shock intensity. A potential as low as 30 volts can cause a fatal current flow. Observe the following practices:

- Work on de-energized equipment when possible.
- Do not work alone.
- Make measurements using one hand (one-hand rule).

**ELECTRIC SHOCK.**—The amount of current that may pass through a person’s body without causing damage depends on the individual and the current quantity, type, and path in addition to the length of time the current passes through the body. A person’s resistance can vary from 300 ohms to 500,000 ohms depending on the condition of his or her body. For example, if a person’s skin is dry and unbroken, resistance can be as high as 500,000 ohms. However, if his or her skin is moist and broken, cut, or burnt, resistance may be as low as 300 ohms. The following are some examples of the effect of current flow through the body:

- At 1 milliamperes (0.001 A), you will feel a shock.
- At 10 milliamperes (0.01 A), shock paralyzes your muscles and you may be unable to release the conductor.
- At 100 milliamperes (0.1 A), shock is usually fatal if the current causing the shock lasts for 1 second or more.

Electric shock produces a jarring, shaking sensation. The victim usually feels like he or she just received a sudden blow. If the voltage and resulting current is high enough, the victim may become unconscious. Severe burns may appear on the skin at the place of electrical contact. Muscular spasm may occur causing the victim to clasp the apparatus or wire that is causing the shock. If this happens, the victim will be unable to release the source of the shock, and you should use the following procedures for rescuing and caring for the shock victim.

Remove victim from the source of electrical shock immediately. **DO NOT ENDANGER YOURSELF.** Remove the victim by throwing the switch if it is nearby, or cut the cable or wires to the apparatus by using an axe with a wooden handle. (Protect your eyes from the flash when you sever the wires.) Also, when you cannot cut the power source off, you can use a non-conductive item to move the electrical source away from the victim or to push or drag the victim to safety. Workbenches should have ropes or wooden canes nearby for such emergencies.

When a person is unconscious because of electrical shock, you cannot tell how much current caused the condition and you should begin CPR immediately if you are qualified to do so

## **TOOL SAFETY**

Tools make a task easier and enable you to work efficiently. If tools are not cared for and used properly, their effectiveness will be lost. A defective tool or improper tool use also increases the possibility of injury to personnel. As a technician you will use a variety of hand tools and power tools. By using each tool correctly you will improve the quality of maintenance and reduce the chance of equipment failure and bodily injury. Always follow the two basic tool safety precautions stated below:

- Use the proper tool for its intended function and use it correctly.
- Keep all tools in working order and in a safe condition.

When using hand tools, observe the following practices:

- Sharpen or replace a dulled cutting tool.
- Protect a tool from damage while it is in use or in stowage.

- If a tool becomes worn, damaged, or broken, turn it in for a replacement.
- Return each tool to its proper stowage place. A loose tool can be a major source of foreign object damage (FOD).

## **Nonmagnetic Tools**

You will use hand tools made of nonmagnetic materials to maintain equipment that can be damaged from magnetized tools. A magnetic-susceptible tool can become magnetized and transfer its magnetic condition to the equipment. When you work near compasses and other components containing permanent magnets, you should always use nonmagnetic tools. Available through normal supply channels, nonmagnetic tools are normally made from beryllium-copper or plastic. They are not as rugged as steel tools and can easily be damaged. If you use nonmagnetic tools properly, they will last longer.

### **WARNING**

Due to toxic hazards, do not etch beryllium-copper tools.

## **Insulated Tools**

Safety considerations require use of insulated hand tools whenever the danger of electrical shock exists. Many types of insulated tools are available directly through supply channels. You should obtain these tools and use them when available. However, many types of insulated tools are not readily available (or are available only at considerable added expense). If a tool is essential, modify the conventional tool or procure the tool by using the following guidance:

- Insulated sleeves may be put on the handle of pliers and wrenches and on the shank of a screwdriver. Because of the limitations of the insulating materials used in sleeves, use a tool modified in this manner only for low-voltage circuits.
- For high-voltage circuits, use special insulating handles that are available for many of the common types of tools.
- When you need a tool that is made of insulating material rather than just using insulating

handles, requisition the tool through normal supply channels.

## Power Tools

In working as an electrical or electronics technician, you will use shop machinery such as a power grinder or drill press. Additional precautions to follow when working with machinery are as follows:

- NEVER operate a machine with the guard or cover removed.
- NEVER operate mechanical or powered equipment unless you know how to operate it. When in doubt, consult the appropriate manual or ask someone who knows.
- NEVER plug in electric machinery without knowing that the source voltage is the same as that called for on the nameplate of the machine.
- Always make sure that everyone is clear of the equipment before starting or operating mechanical equipment.
- Always keep everyone clear of the job site when hoisting heavy machinery or equipment by a chain fall. Guide the hoist with lines attached to the machinery or equipment.
- Cut off the source of power before trying to clear jammed machinery.

Precautions regarding portable electric power tools are as follows:

- Carefully inspect each power tool to be sure the tool is clean, well oiled, and in working order before you use it. For example, the switch should operate normally.
- Ground the casing of each electrically driven tool.
- Do NOT use a sparking tool in any place where flammable vapors, gases, liquids, or exposed explosives are present.

Precautions regarding power cords are as follows:

- A cord should be clean and free of defects.
- Check to make sure that the cord does not come in contact with sharp objects, have kinks, or is left where it may be run over.
- Don't let a cord come in contact with oil, grease, hot surfaces, or chemicals.

- Replace a damaged power cord.
- When unplugging a power tool from receptacles, grasp the plug, not the cord.

## Soldering Irons

The soldering iron is a potential fire hazard and source of burns. Observe the following precautions:

- Always assume a soldering iron is hot.
- NEVER rest the iron anywhere but on a metal surface or rack designed for that purpose.
- Keep the iron in the open to reduce the danger of a fire from accumulated heat.
- DO NOT shake the iron to get rid of excess solder. The hot solder may strike someone or hit the equipment and cause a short circuit.
- Hold a small soldering job with pliers or clamp.
- When cleaning an iron, place the cleaning rag on a flat surface and wipe the iron across it. Don't hold the rag in your hand.
- Disconnect the iron when leaving the work area, even for a short period of time; the delay may be longer than planned.

## GROUNDING

A poor safety ground, or one with incorrect wiring, is more dangerous than no ground at all, because it doesn't offer full protection and it lulls you into a false sense of security. The incorrectly wired ground is a hazard because one of the live wires and the safety ground are transposed. When this happens, the shell of the tool become electrically hot the instant you connect the plug into the outlet, and you will get a shock.

A three-wire, standard color-coded cord with a polarized plug and a ground pin should be used with a power tool. In a properly connected tool, the green wire is the safety ground. This wire attaches to the tool's metal case at one end and to the polarized grounding pin at the other end. The green wire normally carries no current and is in use only when the tool insulation fails. When tool insulation fails, the safety ground short circuits the electricity to ground and protects the user.

To check the grounding system resistance, use a low-reading ohmmeter to be certain the safety ground is adequate. If the resistance is greater than 0.1 ohm, you should use a separate ground strap.

Some old installations do not have receptacles that will accept the grounding plug. If you are assigned to one of these, use one of the following:

- Use an adapter fitting.
- Use the old type plug and bring the green ground wire out separately.
- Connect an independent safety ground wire.

When you use an adapter, connect the ground lead extension to a good ground. DON'T use the center screw that holds the cover plate on the receptacle. Always connect the safety ground first and remove it last. Use the following procedures where separate safety ground leads are connected externally:

- First connect the safety ground, and then plug in the tool.
- Likewise, when disconnecting the tool, first remove the line plug, and then disconnect the safety ground.

## ELECTRICAL FIRES

The four general classes of fires—A, B, C, and D—are defined in most cases by the types of combustible material (or fuel) involved and by the method and agents used to extinguish each. (See table 5-1.) The classes of fires can be defined as follows:

**Table 5-1**

Class of fire	Type of fuel
A	Wood, paper, cotton, wool fabrics, cork, and so forth that leave embers or ashes
B	Cooking and fuel oils, grease, gasoline, jet fuels, kerosene, paint, turpentine, and so forth
C	Electrical in origin and may involve fuels from A, B, and D categories
D	Special metal alloys of magnesium, titanium, zinc and so forth

The electronics and electrical technician should be an expert in the extinguishing of class C (electrical) fires. Class C fires are a special situation in that an additional hazard of electric shock is involved and that the fire must be extinguished without further damage to equipment.

Carbon dioxide (CO<sub>2</sub>) is the preferred extinguishing agent for class C fires. CO<sub>2</sub> does not conduct electricity, evaporates rapidly, and leaves little or no residue. It reduces the possibility of electrical shock to personnel and damage to equipment as a result of contamination.

Another choice of extinguishing agent for class C fires is a dry chemical agent known as Purple-K-Powder (PKP). PKP is a nonconductor, which provides protection against electrical shock; however, damage to electrical or electronic parts may result from the use of PKP.

When fighting electrical fires, you should use the following general procedures:

1. Promptly de-energize the circuit or equipment affected.
2. Sound the alarm according to station regulations or fire bill.
3. Close compartment air vents and windows.
4. Control or extinguish the fire using a CO<sub>2</sub> fire extinguisher.
5. Avoid prolonged exposure to high concentrations of carbon dioxide in confined spaces. You can suffocate due to the displaced oxygen.
6. Administer artificial ventilation and oxygen to a person overcome by carbon dioxide fumes.

### CAUTION

Never use a solid stream of water to extinguish class C (electrical) fires in energized equipment.

Water usually contains minerals that make it conductive. (The conductivity of seawater is many times greater than that of fresh water.) If you must use fresh water or seawater, use a water fog application. When water is broken into small particles as in fog application, the conductivity is greatly reduced. You also must ensure the conductive metal material of the applicator does not come in contact with the energized equipment.

All hands need to know the dangers of fire. An unexpected fire aboard a Navy vessel at sea can kill and injure more people and cause more damage than battle. You need to know the type and location of fire-fighting

equipment and apparatus in your immediate working and berthing spaces and throughout the ship.

## **VOLATILE LIQUIDS**

Volatile liquids—liquids that produce vapors or fumes, such as insulating varnish, lacquer, turpentine, and kerosene—are dangerous when used near operating electrical equipment because sparks from the equipment can ignite their vapors. When these liquids are used in compartments containing non-operating equipment, make sure there is enough ventilation to avoid an accumulation of fumes. Also, in compartments where equipment is to be operated, make sure the space is clear of all fumes before energizing the equipment.

Aviation fuels are hydrocarbons. Handling hydrocarbon products is hazardous because of their low flash point. Products such as gasoline, solvents, and most crude oils begin to vaporize at or below 80°F; their flash point is reached at 80°F. Their flash point makes them the most hazardous petroleum products to handle. Other petroleum products such as kerosene and lubricating oils have a flash point above 80°F, making them less hazardous.

JP-4 fuel has some of the characteristics of gasoline but has a lower vapor pressure and higher aromatic content (compounds added to increase fuel performance). Handle this fuel very carefully.

JP-5 is a kerosene-type of fuel. It has a low vapor pressure (about 0 pounds per square inch [psi]). Its tendency to vaporize is lower than more volatile fuels and the vapor-air mixture above its liquid surface is too lean to ignite. For ignition to occur, the liquid's surface must reach 140°F. Nevertheless, handle this fuel with care.

Take precautions to prevent personnel from breathing fumes from any fuel. The vapors of petroleum, gasoline, and other petroleum products cause drowsiness when inhaled. Petroleum vapors in concentrations of 0.1 percent can cause dizziness to the point where a person cannot walk a straight line after 4 minutes of exposure. Longer exposure and greater concentrations may cause unconsciousness or death. The first symptoms of exposure to toxic (poisonous) vapors are headaches, nausea, and dizziness. When working in an area where there are possible toxic vapors, stay alert. If you get a headache, become dizzy, or become nauseous, you might be exposed to toxic

vapors. You should leave the area and report the condition.

You recover from early symptoms of toxic vapors quickly when you move to an area having fresh air. If you find people overcome by vapors, get them medical attention immediately. First aid consists of the prevention of chilling and, if breathing has stopped, artificial respiration.

Also, prevent fuel from coming in contact with the skin, especially if the skin has abrasions or sores. Repeated contact with gasoline removes protective oils from the skin, causing drying, roughening, chapping, and cracking, and in some cases, infection. If gasoline remains in contact with your skin, it may irritate the skin, particularly under soaked clothing or gloves. Remove clothing or shoes soaked with gasoline at once. When you remove gasoline-soaked clothes, an arc, caused by static electricity, can cause the fuel to ignite. For this reason, remove fuel-soaked clothes in a running shower. Wash gasoline from your skin with soap and water.

If a person swallows gasoline, give first aid immediately. You should give the victim large amounts of water or milk and 4 tablespoons of vegetable oil if available. **DO NOT INDUCE VOMITING. GET THE VICTIM MEDICAL ATTENTION IMMEDIATELY.**

## **COMPRESSED AIR**

When using pneumatic tools, see that nearby workers are not in the line of airflow. Compressed air used to power pneumatic tools, when misused, is dangerous and can cause the following injuries:

- Injuries from a hose or fitting failure that cause the hose to whip dangerously and to propel fitting parts through the air
- Eye injuries from blowing dust and small particles
- Internal injury or even death from air under pressure introducing an airstream into body tissue, usually through an existing cut or scratch
- Ruptured cell tissues and severe wounds from compressed air that injects minute foreign bodies into the skin from impurities that are always in a shop air supply
- Falls from tripping over compressed air hoses thoughtlessly left lying on the floor

### CAUTION

Compressed air is a special tool. Do not use as a substitute for a brush to clean machines, clothing, or your person. When an air hose is essential for blowing out fixtures and jigs, wear eye protection and maintain air pressure below a maximum of 30 psi. It helps to place screens around work to confine the blown particles.

The National Safety Council has published the following general safety rules for working with compressed air:

- Use only sound, strong hose with secure couplings and connections.
- Make sure there aren't any sharp points or metal hose parts.
- Close the control valve in portable pneumatic tools before turning on air.
- Turn off air at the control valve before changing pneumatic tools. Never kink a hose to stop the air flow.
- Wear suitable goggles, mask, protective clothing, or safety devices.
- Never use air to blow dust chips from work clothing or from workbenches.
- Never point the hose at anyone. Practical jokes with compressed air have caused painful deaths.

- Q5-1. *Who is responsible for safety?*
- Q5-2. *What precaution should you take before removing a fuse?*
- Q5-3. *What is required for an individual to perform CPR?*
- Q5-4. *Where can you find danger areas for a particular aircraft?*
- Q5-5. *Who should be standing by while working on energized equipment?*
- Q5-6. *What criterion determines shock intensity?*
- Q5-7. *Which tools should not be etched?*
- Q5-8. *What is the preferred extinguishing agent for Class C fires?*
- Q5-9. *What is the maximum psi of compressed air for cleaning equipment?*

## MAINTENANCE CATEGORIES

**LEARNING OBJECTIVE:** Identify the two maintenance categories and types of work done in each category.

Maintenance performed on equipment falls into the following two broad categories:

- Scheduled maintenance, which consists of actions taken to reduce or eliminate failure and prolong the useful life of the equipment
- Unscheduled maintenance, which consists of actions taken when a part or component has failed and the equipment is out of service

In maintenance work of any kind, you will need two basic kinds of knowledge. First, you must have specific information that applies to the particular equipment you are repairing or keeping in good condition. Second, you must have certain general skills and knowledge of procedures that apply to many kinds of equipment and types of work assignments.

*Specific information* consists of special procedures and processes and detailed step-by-step directions. This information is approved by the proper authority and recommended for a particular piece of equipment. Information is available in publications or checklists from the Naval Air Systems Command (NAVAIRSYSCOM), type commanders, or other authorized sources. The *general maintenance skills and knowledge of procedures* are not available in equipment manuals and are the skills and procedures that must be learned during on-the-job training.

### SCHEDULED MAINTENANCE

Scheduled (preventive) maintenance is performed to reduce the likelihood of future troubles or malfunctions. This form of maintenance consists mainly of visually checking the equipment before and during operation, cleaning the equipment and the various components, lubricating, and performing periodic inspections.

#### Visual Checks

Before you apply power to equipment, visually check equipment for loose leads, improper connections, and damaged or broken components. This type of check applies particularly to new equipment, equipment returned from overhaul, and preserved equipment. Also, it applies to equipment stored for long periods, and equipment that has been exposed to the



weather. A close visual inspection of O-rings, gaskets, and other types of seals are necessary when the equipment under check has pressurized components. This visual inspection often reveals easily correctable discrepancies with a minimum amount of labor and parts. Such discrepancies, if left uncorrected, might result in a major maintenance problem.

## Cleaning

Cleaning the equipment and various components consists of removing dust, grease, and other foreign matter from the covers, chassis, and operating parts. Cleaning includes removing corrosion, fungus, and all other types of matter that could cause operating failure of the equipment. The method used to clean the various parts and units will vary, but usually a vacuum cleaner is good for removing the loose dust and foreign matter. Other types of foreign matter can be wiped off using a clean, lint-free cloth.

If you need to remove grease or other petroleum deposits, moisten the cloth with alcohol, dry-cleaning solvent, or some other approved degreaser. After removing the grease, wipe the part dry and clean before you apply power to the equipment.

For more specific details on corrosion removal, you should refer to *Avionics Cleaning and Corrosion Prevention/Control*, NAVAIR 16-1-540.

## Lubrication

Lubrication of electronic equipment consists of lubricating the mechanical parts that work with the electronic equipment. Parts, such as unsealed bearings, antenna drives, and waveguide rotating joints may require lubrication as directed by the MIM for the equipment. Using the correct specification number is very important because the viscosity of a lubricant changes with a change in operating temperature. High operating temperatures cause lubricants to become thin, and low operating temperatures cause lubricants to thicken or harden. Therefore, the lubricant for a particular job depends on operating characteristics and temperature. You should pay particular attention to equipment lubrication for aircraft that fly at high altitudes. At high altitudes, aircraft require a special lubricant that will not harden. This reduces physical overload on the drive motors and shafts and electrical overload on the circuits involved.

## Periodic Inspections

Periodic inspections or preventive maintenance services (PMS) ensure aeronautical equipment is maintained throughout its life cycle by controlling degradation resulting from time, operational cycles, use, or climatic exposure. PMS, properly conducted, will ensure equipment receives the necessary servicing, preventive maintenance, and inspections required.

Scheduling is the primary factor in the successful and efficient completion of a PMS action. The main tools used to accomplish effective inspections are the following PMS publications:

- PMIC-Periodic Maintenance Information Card
- MRC-Maintenance Requirement Card
- SCC-Sequence Control Card
- AESR-Aeronautical Equipment Service Record
- SRC-Scheduled Removal Component
- EHR-Equipment History Record
- ASR-Assembly Service Record

## UNSCHEDULED MAINTENANCE

Unscheduled maintenance is the performance of a repair action without a set interval. Discrepancies found before, during, and after flights or during operational checks fall into this category. When finding defective parts, or if unsatisfactory operation occurs, you must analyze the equipment, determine the defective part or parts, and replace or repair the part. In general, the most effective method for this analysis is a logical step-by-step troubleshooting procedure.

*Q5-10. What are the two broad categories of maintenance?*

*Q5-11. Scheduled maintenance consists of what type of work?*

*Q5-12. What manual should you refer to for avionics corrosion removal?*

## TROUBLESHOOTING

**LEARNING OBJECTIVE:** Identify troubleshooting techniques for analyzing, detecting, and correcting faults in electrical equipment. Recognize proper aircraft maintenance practices. Recognize proper bench maintenance procedures.

Most of your maintenance time is spent troubleshooting the equipment within your squadron's aircraft. Your job is to maintain several units and systems using both aircraft and bench procedures. Many systems are complex and might seem, at first glance, to be beyond your ability to maintain. However, the most complex job usually becomes much simpler if it is broken down into successive steps. Any maintenance job should be performed in the following order:

1. Analyze the symptom
2. Detect and isolate the trouble
3. Correct the trouble and test the work

## AIRCRAFT PROCEDURES

Aircraft procedures for troubleshooting include tests for continuity, grounded circuits, shorts, and voltage.

In troubleshooting, there is no substitute for common sense. Most beginners make a common mistake; they remove major units from the aircraft unnecessarily. The first step you should take when receiving a discrepancy is to determine if the equipment in question is actually faulty. Very often, a preliminary visual check of the system will show a faulty control box, frayed or broken wiring, or corroded or wet connectors. In some cases, you may not find an equipment fault but someone using an improper operating procedure—especially with new equipment. (Improper operating procedures are especially common when the reported discrepancy involves new equipment or when operating personnel are undergoing indoctrination.)

If there is no power present at the input to the equipment, you may assume (temporarily) that the set is not broken. You should check all applicable switch positions, circuit breakers, fuses, and other common problems. Then, check for power at the electrical bus that feeds the equipment. Check the tightness of connections and the physical condition of interconnecting cables. Using the wiring diagrams in the applicable manuals, you should check at successive tie points and splices for continuity, short circuits, or grounds.

If a circuit breaker trips or if a fuse blows, it indicates a circuit malfunction. Turn off power to the circuit containing the open, and do not reapply power until you locate and correct the malfunction. The most common causes of tripped or blown circuit protectors are short circuits, faulty grounds, or overload con-

ditions. However, circuit protectors sometime fail because of age or other conditions. If, after a thorough check, there is no clear reason for the failure, reset the breaker or replace the fuse. Make sure the replacement fuse is the proper size and type, then reapply the power.

The analysis may not indicate the existence of a short circuit, faulty ground, or overload condition. If the equipment still does not operate, you should continue to take measurements with power applied. **Observe all safety precautions.** Systematically take these measurements at progressive checkpoints. Particular faults that can interrupt current through a circuit include broken wiring, loose or faulty terminal or plug connections, faulty relays or switches, and uncoupled splices. Be alert for these conditions!

Sometimes, you cannot determine the defective unit while it's still installed in the aircraft. You may need to turn off the power and replace units, one at a time, with units that operate properly. After replacing each unit, reapply power and check the system for proper operation. If the system operates normally, you have found the faulty unit. You may then take the bad unit to the shop for corrective maintenance. At this stage of the overall maintenance process, you should try to determine the reason for the failure of the unit. If the basic cause has not been corrected, it is possible the new unit also may become damaged.

After you have removed the defective unit and further analyzed it, reinstall all other items of the original installation and safety wire. Then, perform a complete operational check. During the operational check, readjust or calibrate as necessary. This should be done before you clear the discrepancy (indicate the unit has been fixed and is in operating condition) on the original maintenance action form.

The rules shown here are a guide you can use when making troubleshooting tests:

- **Always** connect an ammeter in series.
- **Always** connect a voltmeter in parallel.
- **Never** connect an ohmmeter to an energized circuit.
- Select the highest range first, and then switch to lower ranges, as needed.
- When using an ohmmeter, select a scale that will result in a mid-scale reading.
- **Do not** leave the selector switch of a multi-meter in the resistance position when the meter is not

in use. The leads may short together and discharge the internal battery. There is less chance of damaging the meter if you leave it on a high ac voltage setting or in the OFF position. Meters that have an OFF position dampen the swing of the needle by connecting the meter movement as a generator. This prevents the needle from swinging wildly when the meter is moved.

- View the meter from directly in front to eliminate parallax.
- Observe polarity when measuring direct current (dc) voltage.
- **Do not** place meters in the presence of strong magnetic fields.
- **Never** try to measure the resistance of a meter or a circuit with a meter in it. The high current required for ohmmeter operation may damage the meter. This also applies to circuits with low-filament current tubes and some types of semiconductors.
- When measuring high resistance, be careful not to touch the test lead tips or the circuit. Your body resistance will shunt the circuit and cause an erroneous reading.
- Connect the ground lead of the meter first when making voltage measurements. Work with one hand whenever possible.

## Continuity Test

Open circuits are circuits that interrupt current flow, either from a broken wire, defective switch, or any other means that stops current flow. To check for opens (or to see if the circuit is complete or continuous) you conduct a *continuity test*.

An ohmmeter, which contains its own batteries, is an excellent tool to use when you perform a continuity test. (In an emergency, a flashlight can function as a continuity tester.) Normally, you make continuity checks in circuits where the resistance is very low, such as the resistance of a copper conductor. A very high or infinite resistance indicates an open circuit. Such a condition would be an open conductor.

Look at figure 5-2. It shows a continuity test of a cable. When using an ohmmeter, make sure you disconnect both connectors and connect the ohmmeter in series with the conductor under test. The power must be off. When you are checking conductors A, B, and C, the current from the ohmmeter flows through plug 2, the conductor, and plug 1. From this plug, it passes through the jumper to the chassis ground and to the aircraft's structure. The structure serves as the return path of the current to the chassis of unit 2, completing the circuit to the ohmmeter. The ohmmeter will indicate a low resistance.

Checking conductor D reveals an open. The ohmmeter indicates maximum resistance because current cannot flow. With an open circuit, the

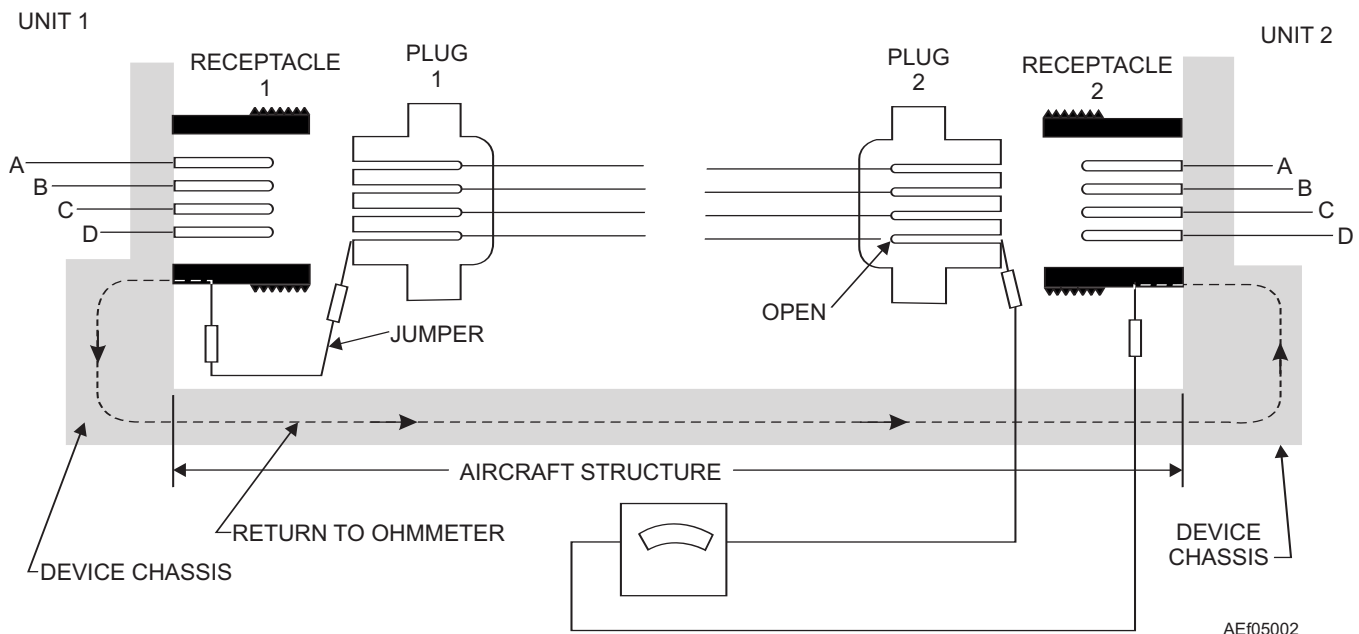

Figure 5-2.—Continuity test.

ohmmeter needle is all the way to the left, since it is a series-type ohmmeter (reads right to left). (A digital ohmmeter would read overload or “OL” in its display.)

You cannot use the aircraft structure as the return path; use one of the other conductors. For example, to check D, connect a jumper from pin D to pin A of plug 1 and the ohmmeter leads to pins D and A of plug 2. By the process of elimination, this technique will also reveal the open in the circuit.

### **Grounded Circuit Test**

Grounded circuits may be caused from either direct or indirect contact between some conducting part of the circuit and the metallic framework of the aircraft. Grounds may have many causes. Perhaps the most common cause of a ground is frayed wire insulation that allows the bare wire to come into contact with the metal ground.

Grounds are usually indicated by blown fuses or tripped circuit breakers. Blown fuses or tripped circuit breakers, however, also may result from a short other than a ground. A high-resistance ground also may occur where enough current does not flow to rupture the fuse or open the circuit breaker.

Ohmmeters provide a good test for grounds. You also may use other continuity testers. By measuring the resistance to ground at any point in a circuit, you can determine if the point is at ground potential. Look at figure 5-2 again. It shows a way to test a cable for grounds. If you remove the jumper from pin D of plug 1, a test for grounds can be made for each conductor of the cable. This is done by connecting one meter lead to ground and the other to each of the pins of one of the plugs. A low-resistance reading on the ohmmeter indicates a grounded pin. You must remove both plugs from their units. If you remove only one plug, a false indication is possible. This false indication occurs because the other conductor receives a ground through the unit.

### **Short Test**

A short-circuit test is a test to determine whether two conductors have accidentally touched each other, directly or through another conducting element. Two conductors with frayed insulation may touch and cause a short. Too much solder on one pin of a connector may short it to an adjacent pin. In a short circuit, sufficient current may flow to blow a fuse or open a circuit breaker. However, it is entirely possible to have a short

between two cables carrying signals and not blow a fuse.

The device used to check for a short is the ohmmeter. By measuring the resistance between two conductors, you may detect a short between them. A low-resistance reading usually indicates a short. Look at figure 5-2. You may perform a short test by removing the jumper and disconnecting both plugs. This is done by measuring the resistance between the two suspected conductors.

Shorts can occur in many components, such as transformers, motor windings, and capacitors. The major method for testing such components is to take a resistance measurement and then compare the indicated resistance with the resistance given on schematics or in maintenance manuals. You also may make comparisons with identical operational equipment.

### **Voltage Test**

You make voltage tests with the power applied. Therefore, you must follow the prescribed safety precautions to prevent injury to yourself and others or damage to the equipment. Making voltage tests is an important part of maintenance work. It lets you isolate discrepancies to major components, and you can use these tests in the maintenance of subassemblies, units, and circuits. Before checking a circuit voltage, you should check the voltage of the power source to make sure normal voltage is being input to the circuit.

## **BENCH PROCEDURES**

When doing bench procedures for troubleshooting, tests can involve signal tracing, test probe substitution, voltage and resistance checks, replacing defective parts, and checking after repair.

The visible condition of a unit is usually the first check in any troubleshooting process. If certain parts are obviously not in good condition, correct them before you resume testing. Such faults include burned, loose, disconnected, dented, broken, or otherwise obviously faulty parts. Check the visible condition of a unit before installing and connecting the unit at the test bench.

The sense of smell can help pinpoint certain troubles. A part that overheats usually gives off an odor that is readily detectable. However, location of a burned part does not necessarily reveal the cause of the trouble.

To determine the cause of the trouble, you should refer to the MIM for the given equipment. The MIM is a source of valuable information for performing maintenance on electronic equipment.

### Signal Tracing

Signal tracing is a good method for tracing signals in RF receivers and audio amplifiers. However, in radar, the frequencies are higher, the methods of signal application differ, and the output in the final stage is video (viewed). The applicable MIM contains detailed procedures for testing most units or circuits.

Signal tracing is a very effective method for locating defective stages in many types of electronic sets. It is especially useful when servicing equipment that normally contains no built-in meters. In signal tracing, a signal voltage, similar to that present under operating conditions, from a signal generator is input to the circuit in question. The signals that result are then checked at various points in the stage by using a high-impedance test instrument. The particular test equipment, such as a vacuum tube voltmeter, an oscilloscope, or an output meter, depends on circuit application and other parameters. The test instrument should have high impedance so that it will not change the operation of the circuit under test.

When using the signal tracing to measure ac signals, you should make sure the test instruments are adequately isolated from any dc potential present in the circuit. Some test instruments have special ac probes that incorporate a capacitor in series with the input. Before using any item of test equipment, you must know the characteristics and proper use of the test equipment as well as the equipment under test.

By using the signal-tracing method, you can measure the signal gain or loss of amplifiers. You also can locate the points of origin of distortion, hum, noise, and oscillation that occur in the amplifiers.

The gain measurement is a good example of an important method in signal tracing. By this procedure, you can quickly isolate a discrepancy to the defective stage. A signal generator, with the output attenuator calibrated to microvolts, and an output meter can measure gain. It is helpful to have data on the normal gain of the various stages of the device. You can find this data in the MIM for the receiver under test.

To measure gain, you connect the output meter across the headset (or the voice coil of a speaker) or across the secondary of the output transformer. Connect

the output of the signal generator to the grid circuit of the stage under test. Then, adjust the attenuator of the signal generator until the output meter reads a value appropriate to serve as a reference figure. After adjustment, connect the output of the signal generator to the output of the stage under test (or to the input of the next stage). Adjust the attenuator until registering the same reference value on the output meter. To determine the gain of the stage, divide the second value of the signal (taken from the calibrated attenuator) by the value of the signal applied to the input of the stage. For example, suppose the signal generator supplies a voltage of 400 microvolts to the grid of an IF amplifier. This voltage causes the output meter to indicate some value you can use as a reference. When the generator signal is input to the following grid, the signal strength must be increased (4,000 microvolts) to cause the output meter to indicate the same reference value. The gain of the stage is equal to  $\frac{E_{in} \text{ 2nd stage}}{E_{in} \text{ 1st stage}}$ ; where  $E_{in}$  = voltage of the input, that is,  $\frac{4,000}{400} = 10$ .

If similar measurements made in the remaining stages of the receiver reveal one stage in which the gain is lower than normal or is zero, a faulty stage is indicated. Then, you can check that stage thoroughly by measuring voltage or resistance or by replacing parts until you find the defective one.

### Test Probe Substitution

Do not use a test equipment probe with equipment other than that for which it is designed, as an improper test probe may not have sufficient capacitive adjustment to preserve the waveshape of the observed signal. Any differences in the internal resistance of the probe and input circuitry of the equipment make substitution impossible without calibration. For example, the internal resistance of a 10:1 probe is usually nine times higher than the input circuitry of the equipment. You should note that 2:1, 50:1, and 100:1 probes also are available.

### Voltage Checks

You should make voltage measurements at various points in the stage suspected of being faulty. Compare the observed voltage values with the normal voltage values given in the MIM. When making voltage checks for comparison with a chart, you should use a voltmeter with the proper ohms-per-volt rating (sensitivity). **Always connect voltmeters in shunt with the circuit**

**elements under test.** This results in circuit loading. The sensitivity of the test instrument must be the same as that of the instrument used to make the readings on the chart. This ensures the loading effect will be the same in both cases, and your meter readings should be reliable. Remember, if the meter sensitivity is too low, the loading effect may be so severe that it will prevent proper operation of an otherwise normally functioning circuit.

By comparing observed voltages with the voltages given in the MIM, you can often isolate the defect. Voltage checks are most effective when applied within a single stage after you have made checks to localize the defect, because modern electronic equipment is complex, and requires time to check all the voltages present in all the stages.

Some electronic sets have built-in meters or plugs for front panel application of meters. These meters usually work with a selector switch and read voltage or current values at set points. Normally, you can isolate a defective stage in this manner.

After isolating the defective stage, it becomes a matter of point-to-point checking to isolate the fault within the stage itself. A voltmeter will pinpoint the trouble, but it often becomes necessary to use an ohmmeter to determine the exact cause of trouble; for example, shorted capacitors, open resistors or transformers, or a wire grounded to chassis.

### Resistance Checks

Like voltage measurement, resistance checks are most effective after you isolate the trouble to a particular stage. After isolating the trouble, the ohmmeter is a very useful instrument, and often quickly leads you, the technician, to the cause of the trouble. Resistance checks are made like voltage checks, except you must remove power from the set. You measure resistance and compare your readings to the normal values given in the maintenance publications. Reliance on resistance measurement alone is too time-consuming to be efficient.

**NOTE:** To prevent damage to the ohmmeter, always be sure there are no voltages present in the equipment before beginning the resistance checks. Turn off the power switches, discharge the power supply and other large capacitors, and bleed off any other residual charges in the set. Also, observe proper precautions when connecting or disconnecting the ohmmeter across large inductors.

Routine resistance checks on an electrolytic capacitor may be done with an ohmmeter. You make a resistance measurement on the discharged capacitor using the high resistance range of the ohmmeter. When you first apply the ohmmeter leads across the capacitor, the meter pointer rises quickly and then drops back to indicate high resistance. Now, if you reverse the test leads and reapply them, the meter pointer rises again, even higher than before, and again drops to a high value of resistance. The battery of the ohmmeter charges the capacitor and causes the meter to deflect. When reversing the leads, the voltage in the capacitor adds to the applied voltage, resulting in a greater deflection than at first.

### WARNING

Do not leave the ohmmeter connected across an electrolytic capacitor for any length of time. Electrolytic capacitors are polarity sensitive, and reverse polarity of voltage (even from an ohmmeter) may cause excessive current, which could result in overheating and possible explosion of the capacitor.

If the capacitor is open-circuited, no deflection will occur. If the capacitor is short-circuited, the ohmmeter indicates zero ohms. The resistance values registered in the normal electrolytic capacitor result from the slight current leakage between the electrodes. Because the electrolytic capacitor is a polarized device, the resistance is greater in one direction than the other.

If a capacitor indicates a short circuit, you must disconnect one end of it from the circuit. Then, take another resistance reading to determine if the capacitor is actually at fault.

Unless the ohmmeter has a very high resistance scale, you will not be able to see any meter deflection when you are checking small capacitors. Even a scale of  $R \times 10,000$  is not enough for very small capacitors. The smaller the capacitor, the less leakage across the plates; therefore, the more resistance.

When making resistance checks, you need to determine what circuits connect to the checkpoints. The MIM indicates the proper resistance at various checkpoints throughout the set. Also, the MIM contains a complete schematic of the set, as well as a circuit schematic of the stage under test. The schematics may set up conditions for performing voltage and resistance measurements. These conditions may include the positions of switches and control knobs, relays

energized or de-energized, and tubes in sockets. These conditions duplicate the initial measurement conditions with which you are comparing your readings. Typical instructions might read "Power switch OFF—all controls on the control box full CCW (counterclockwise)." By following these instructions, you should get accurate values to compare with the specified values.

### Defective Components

Before you replace a defective part, determine if such an operation is within your activity's capability. The maintenance that you can perform is a function of your activity's assigned level of maintenance. Because electronic equipment is complex and compact, the trend in the Navy is toward replacement of subassemblies instead of individual parts. This trend stems from the necessity of exact parts replacement and the difficulty of working in small spaces. Even the amount of solder used on a connection is important. However, there are many parts that you may replace at any level of maintenance. The general rule is to replace any defective part with an exact duplicate.

You should refer to the specific MIM, illustrated parts breakdown (IPB), and supply publications to help get information (such as stock number and description) about a particular part. The publication that you will use most often when ordering parts for the particular equipment under repair is the IPB.

If you consider a substitute part, make sure the substitute part is a proper replacement. (See table 5-2.)

For example, one of the most important considerations when you replace a resistor is the wattage value of the resistor. The wattage rating is a measure of the ability of the resistor to dissipate heat. The wattage value is a function of the dimensions of the resistor. Your selection of a resistor with a safe wattage

value should be based on a consideration of the working conditions of the resistor in the circuit.

Consider the replacement of an 850-ohm resistor with one of equal ohmic value but with a tolerance of 20 percent. Suppose the normal voltage existing across the resistor is 40 volts. Because of the 20 percent tolerance, the actual resistance of the replacement may be as much as 1,020 ohms or as little as 680 ohms. If you choose the resistor with the lesser value (the more unfavorable from a heat-dissipating standpoint), you can find the power that may be developed in the resistor under circuit conditions as follows:

$$W = \frac{E^2}{R}$$

Where  $W$  = power in watts,  $E$  = potential in volts, and  $R$  = resistance in ohms.

$$W = \frac{40 \times 40}{680}$$

or

$$W = 2.4 \text{ watts, approximately}$$

### Checking After Repair

No repair job is complete until you reinstall the repaired unit or component and check to see that it is operating properly. The component must be bench checked after correcting the trouble. Before completely reassembling the component, you should make any alignment or adjustments that are necessary for the proper operation of the component. After re-assembly of the component, replace dust and shielding covers, install the component in the outer case (and pressurize, if necessary), and perform a final bench operational check. Often, when a shield or plate is installed, the shield or plate will touch a bare wire or make other contact and make the component inoperative or cause substandard operation. It is much better to discover such a fault at the bench than in the aircraft.

Table 5-2

IF the component to be replaced is a ...	THEN you must ...
Resistor	Match its ohmic value, wattage rating, tolerance, type of construction, and physical dimension.
Capacitor	Match its capacity, voltage rating, tolerance, temperature coefficient, and physical dimension.
Plug or connector	Use an exact replacement in most cases, because it is difficult to find an interchangeable item of this type.

Table 5-3A

Step	Action
1	Try to locate the trouble by observing the circuit's faulty operation. Did you find the trouble?  If <b>yes</b> , go to step 6. If <b>no</b> , go to step 2.
2	Try to locate the trouble by using eyes and nose. Did you find the trouble?  If <b>yes</b> , go to step 6. If <b>no</b> , go to step 3.
3	Localize the trouble at the faulty SECTION by testing techniques. Did you find the trouble?  If <b>yes</b> , go to step 6. If <b>no</b> , go to step 4.
4	Localize the trouble at the faulty STAGE by testing techniques. Did you find the trouble?  If <b>yes</b> , go to step 6. If <b>no</b> , go to step 5.
5	Localize the trouble at the faulty CIRCUIT or PART by testing techniques and go to step 6.
6	Replace or repair the defective part.
7	Test the circuit's operation readjust the circuit.

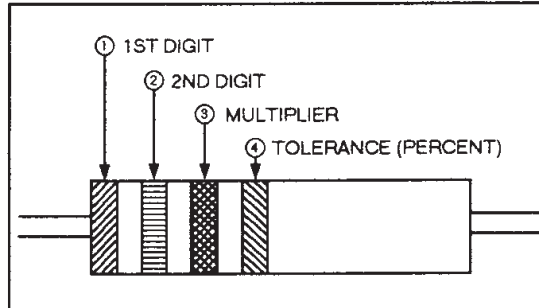

COLOR	1ST DIGIT	2ND DIGIT	MULTIPLIER	TOLERANCE (PERCENT)
BLACK	0	0	1	
BROWN	1	1	10	
RED	2	2	100	
ORANGE	3	3	1,000	
YELLOW	4	4	10,000	
GREEN	5	5	100,000	
BLUE	6	6	1,000,000	
VIOLET	7	7	10,000,000	
GRAY	8	8	100,000,000	
WHITE	9	9	1,000,000,000	
GOLD			.1	5
SILVER			.01	10
NO COLOR				20

RESISTORS FOR MILITARY USE MAY HAVE A FIFTH BAND TO INDICATE RELIABILITY IN TERMS OF FAILURE RATE, AS FOLLOWS:

NO COLOR: NO TEST MADE  
 BROWN : 1.0 PERCENT PER 100 HOURS  
 RED : 0.1 PERCENT PER 100  
 ORANGE : 0.01 PERCENT PER 100 HOURS  
 YELLOW : 0.001 PERCENT PER 100 HOURS

AEF05003

Figure 5-3.—Resistor color codes.



After installing the component in the aircraft and properly securing it for flight, you must give it a final operational test. You cannot assume that because the component operated properly on the bench it will do so in the aircraft. The most important test is an operational check under exact operating conditions. When the component performs properly in the aircraft and is secure, you may sign off the discrepancy sheet (maintenance action form). Your signature indicates that the electronic component should operate properly under normal flight conditions.

The following steps and actions summarize the troubleshooting steps: (See table 5-3A).

## COLOR-CODE SYSTEMS FOR COMPONENTS

As a technician, you need to know the different color codes that identify resistors, capacitors, wiring, and other components. Resistor color codes (fig. 5-3) lets you quickly identify size (in ohms) and tolerances. You can use color codes, along with *Resistors, Selection and Use of MIL-HDBK-199* to identify or find suitable replacements.

Capacitor color-coding is one of two methods used to identify capacitors. Figures 5-4, 5-5, 5-6, and 5-7 are several examples of capacitor color coding for different

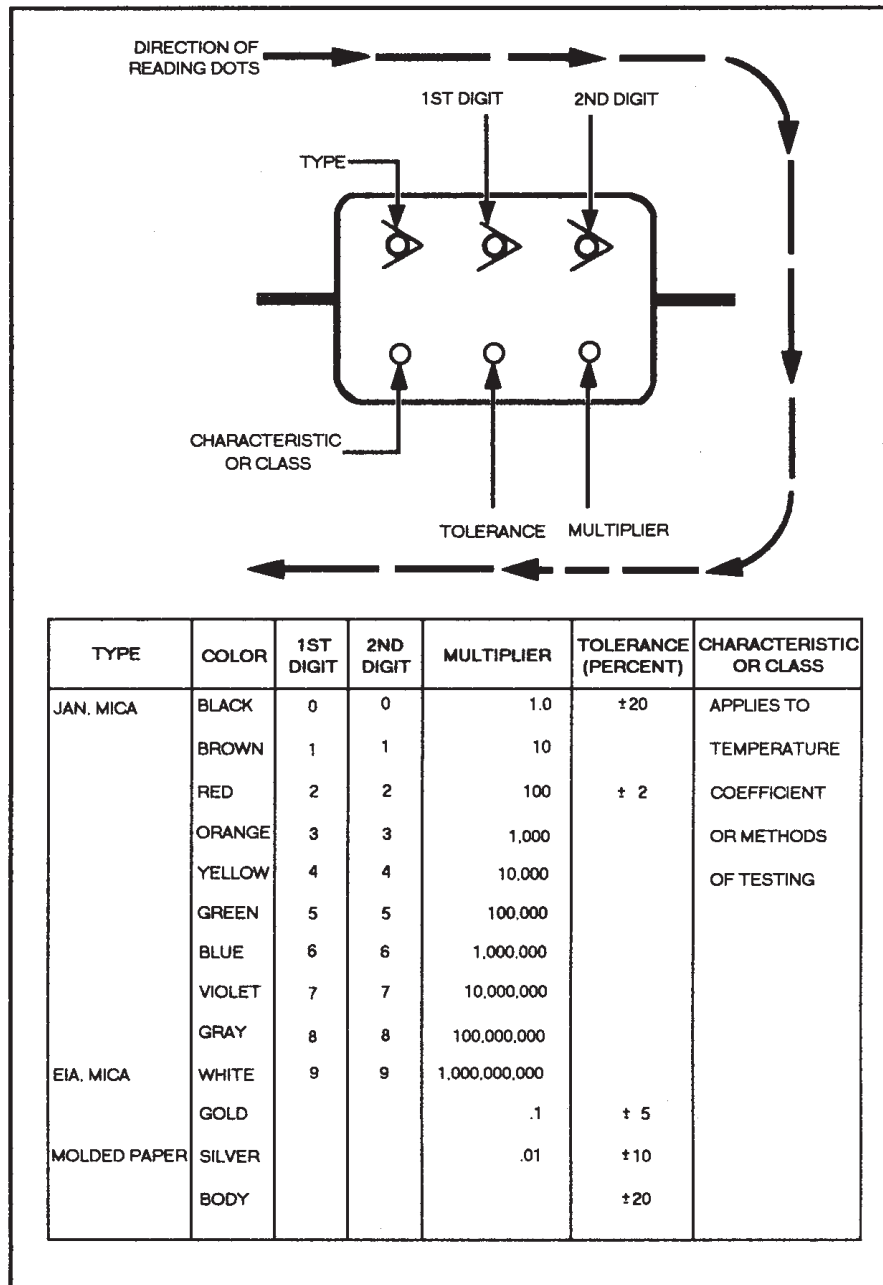

AEF05004

Figure 5-4.—Six-dot color code for mica and molded paper capacitors.

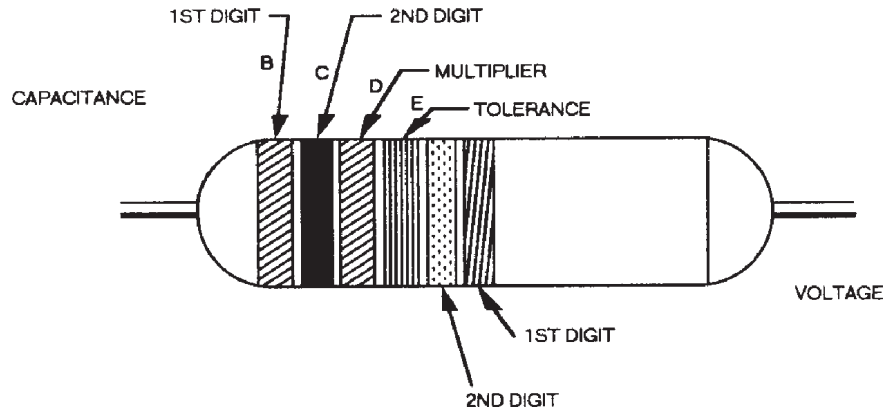

COLOR	CAPACITANCE			TOLERANCE (PERCENT)	VOLTAGE RATING	
	1ST DIGIT	2ND DIGIT	MULTIPLIER		1ST DIGIT	2ND DIGIT
BLACK	0	0	1	±20	0	0
BROWN	1	1	10		1	1
RED	2	2	100		2	2
ORANGE	3	3	1,000	±30	3	3
YELLOW	4	4	10,000	±40	4	4
GREEN	5	5	100,000	±5	5	5
BLUE	6	6	1,000,000		6	6
VIOLET	7	7			7	7
GRAY	8	8			8	8
WHITE	9	9		±10	9	9

AEf05005

Figure 5-5.—Six-band color code for tubular paper dielectric capacitors.

B - A - TEMPERATURE COEFFICIENT  
 B - 1ST DIGIT  
 C - 2ND DIGIT  
 D - MULTIPLIER  
 E - TOLERANCE

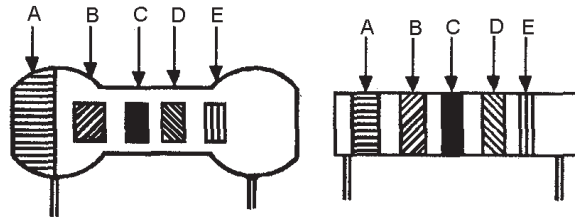

RADIAL LEAD CERAMICS

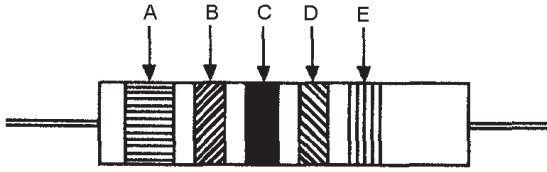

AXIAL LEAD CERAMIC

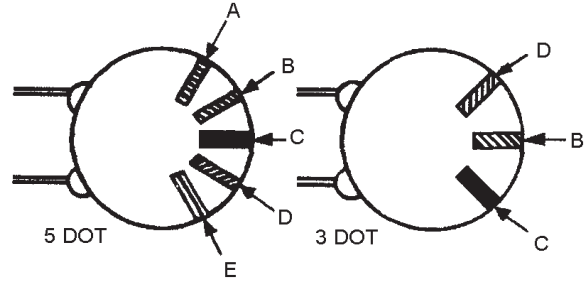

CERAMIC DISC CAPACITOR MARKING

COLOR	1ST DIGIT	2ND DIGIT	MULTIPLIER	TOLERANCE		TEMPERATURE COEFFICIENT*
				MORE THAN 10pf (IN PERCENT)	LESS THAN 10pf (IN pf)	
BLACK	0	0	1.0	±20	±2.0	0
BROWN	1	1	10	±1		-30
RED	2	2	100	±2		-80
ORANGE	3	3	1,000			-150
YELLOW	4	4	10,000			-220
GREEN	5	5		±5	±0.5	-330
BLUE	6	6				-470
VIOLET	7	7				-750
GRAY	8	8	.01		±0.25	+30
WHITE	9	9	.1	±10	±1.0	+120 TO -750 (EIA) +500 TO -330 (JAN) +100 (JAN)
SILVER						BYPASS OR COUPLING (EIA)
GOLD						

\* PARTS PER MILLION PER DEGREE CENTIGRADE

AEI05006

Figure 5-6.—Ceramic capacitor color code.

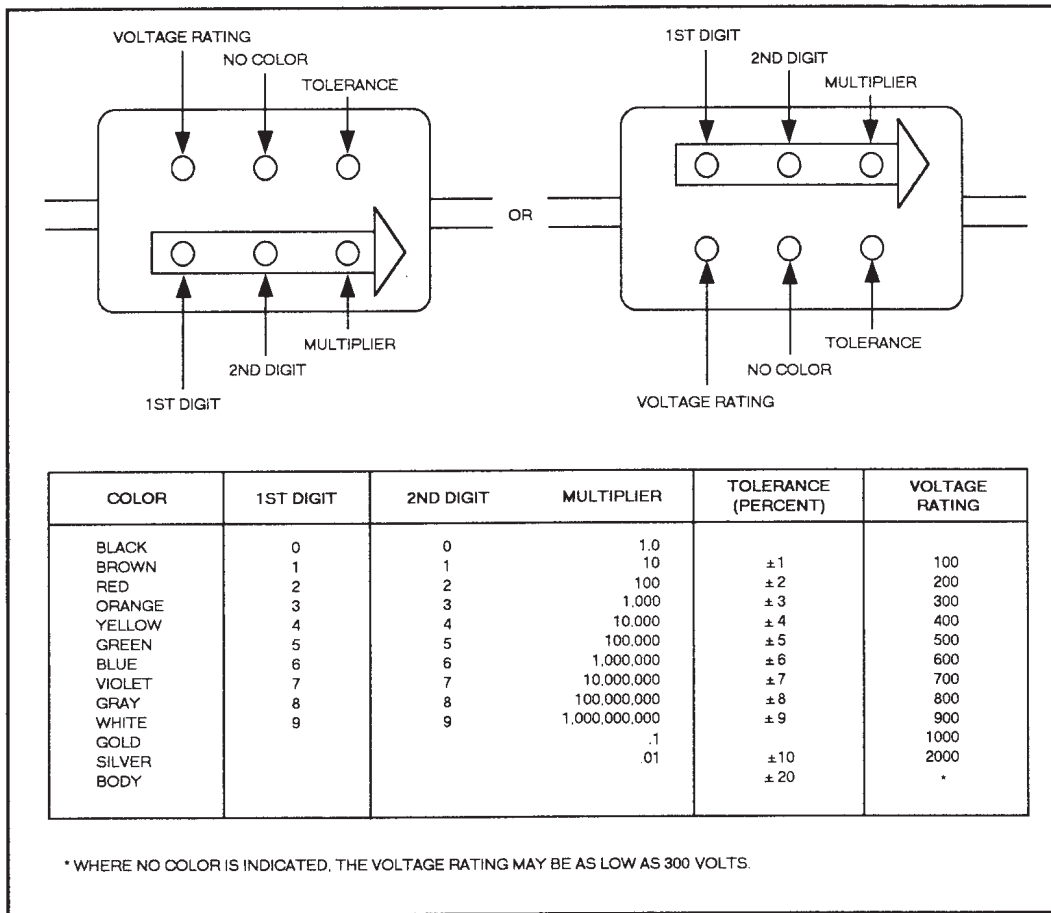

AEf05007

Figure 5-7.—Mica capacitor color code.

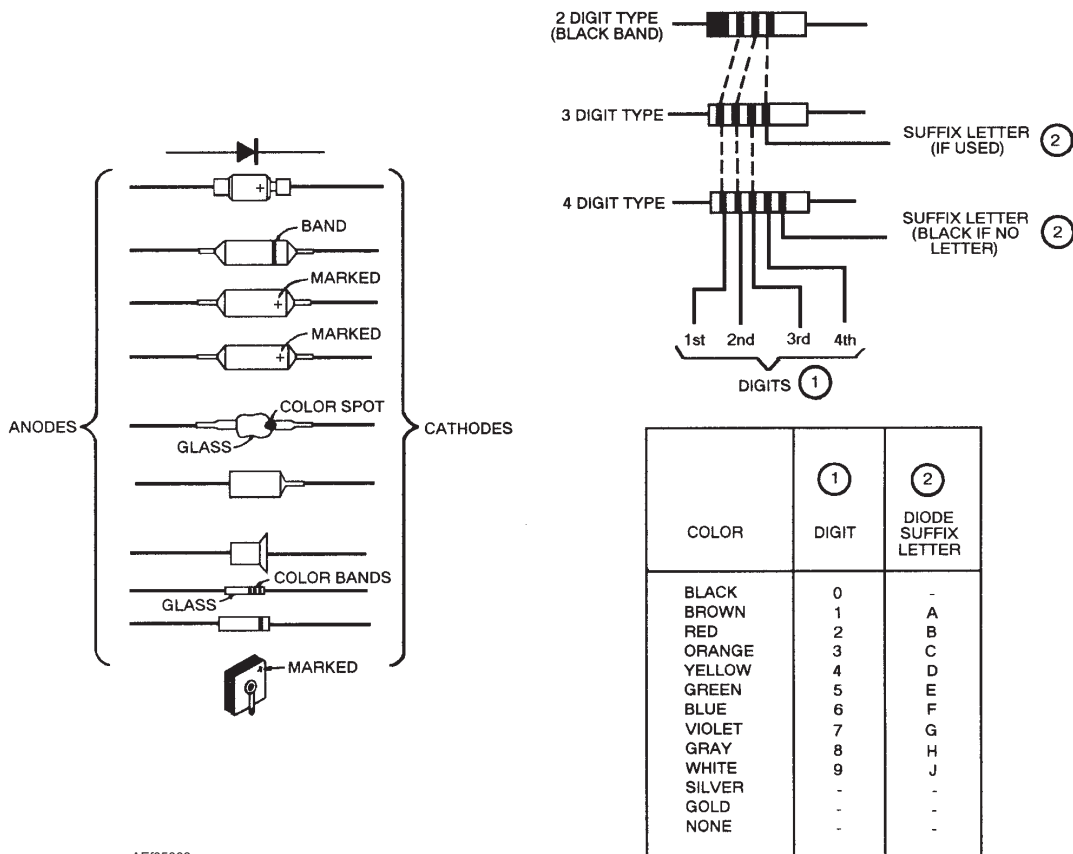

AEf05008

Figure 5-8.—Semiconductor diode markings and color-code system.

styles of capacitors. The other method is the typographical method where a number is stamped on the capacitor.

Semiconductor diodes and transformers also have color-coding identification. See figures 5-8 and 5-9.

To allow a sufficient safety margin, a resistor should be capable of dissipating from 1.5 to 2 times the power it will actually meet. In the above example, this value is not more than 4.7 watts. Since a 5-watt resistor is the next standard size above the 4.7-watt value, this is a desirable wattage rating for the replacement.

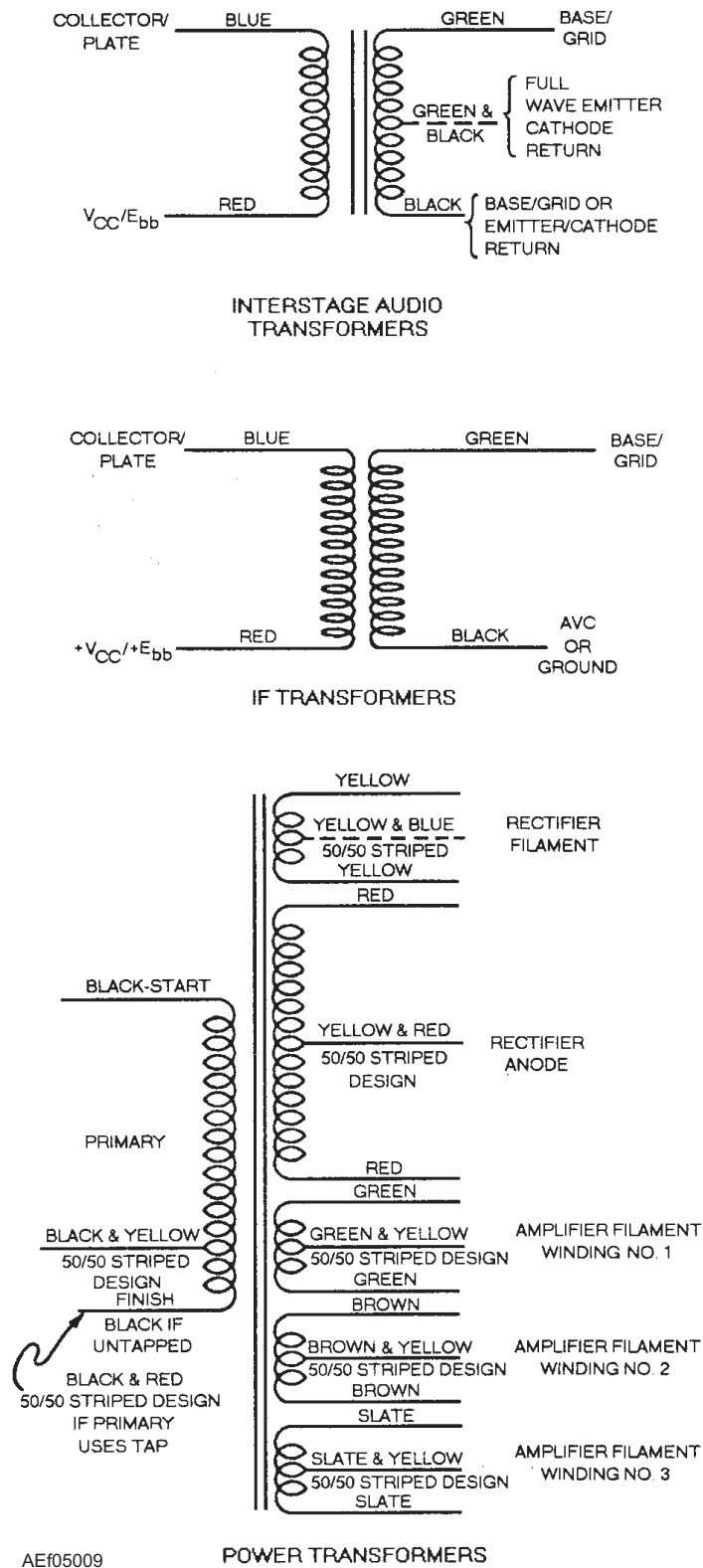

AEf05009

Figure 5-9.—Color codes for transformers.

- Q5-13. What are the two broad categories of maintenance?
- Q5-14. What is the primary purpose of preventive maintenance?
- Q5-15. What is the first step you should take when receiving a discrepancy?
- Q5-16. Describe the use of continuity tests.
- Q5-17. Describe the major method for testing shorts in transformers, motor windings, and capacitors
- Q5-18. What is the effective method of locating defective stages in electronic equipment?
- Q5-19. Use of improper test probes may result in what?
- Q5-20. What should be done before making resistance measurements?
- Q5-21. After complete reassembly of equipment, what must be done?
- Q5-22. What must you consider when substituting a resistor to ensure it is a proper substitution?
- Q5-23. What is the proper color code for a 100 ohm resistor with a 10 percent tolerance?

## AIRCRAFT AND EQUIPMENT WIRING

**LEARNING OBJECTIVES:** Identify various wire and cable characteristics. Identify procedures for installing wiring and cables.

An important part of aircraft electrical maintenance is determining the correct wire or cable (fig. 5-10) for a given job, either replacing or installing wire. For electrical installations, the term *wire* refers to a stranded conductor that is covered with an insulating material. The term *cable*, as used in aircraft electrical installation, includes the following:

- Two or more insulated conductors contained in the same jacket (multiconductor cable)
- Two or more insulated conductors twisted together
- One or more insulated conductors covered with a metallic braided shield (shielded cable)
- A single insulated center conductor with a metallic braided outer conductor (RF cable)

## WIRE REPLACEMENT

After determining the wire or cable size, consider insulation characteristics of the wire or cable. To account for weight discrepancies between the original wire or cable and replacement wire or cable, always refer to NAVAIR 01-1A-505 before selecting the replacement wire or cable. Consider the following factors:

- The need for the insulated wire or cable to be used in combination with wire or cable that has other insulating material
- The temperature and voltage rating ranges of the wire or cable
- The need for the wire or cable to be high-temperature and fire-resistant
- The need for the wire or cable insulation to operate efficiently in high ambient temperatures
- The need for the insulation design of the wire or cable to assure emergency operation of an electrical circuit subject to flaws

To find this information for electrical wire, refer to the military standard (a performance and commercial specification and standard) for wire. To identify the part number for the wire, use the same military specification number that is printed or stenciled on the reel, spool, or shipping container along with wire size. Thus, MIL-W-2538-18 refers to number 18 aircraft wire (W) of the military standard 2538 specification.

Identify electrical cable in the same manner as wire, only with a C (for cable) instead of a W (for wire). Thus, military standard MIL-C-7078 specification describes three types of electrical cable with twisted, color-coded wires as follows:

- Unshielded and unjacketed two or more wires with no overall jacket or shield
- Jacketed two or more wires with no overall shield enclosed within a single jacket
- Shielded and jacketed one or more wires with an overall shield enclosed within a single jacket

Military standard MIL-C-27500 specifies an electrical cable made up of two to seven wires. MIL-C-27500 cable has spirally laid, color-coded wires in the following three configurations:

- Unshielded and unjacketed wires without an overall jacket

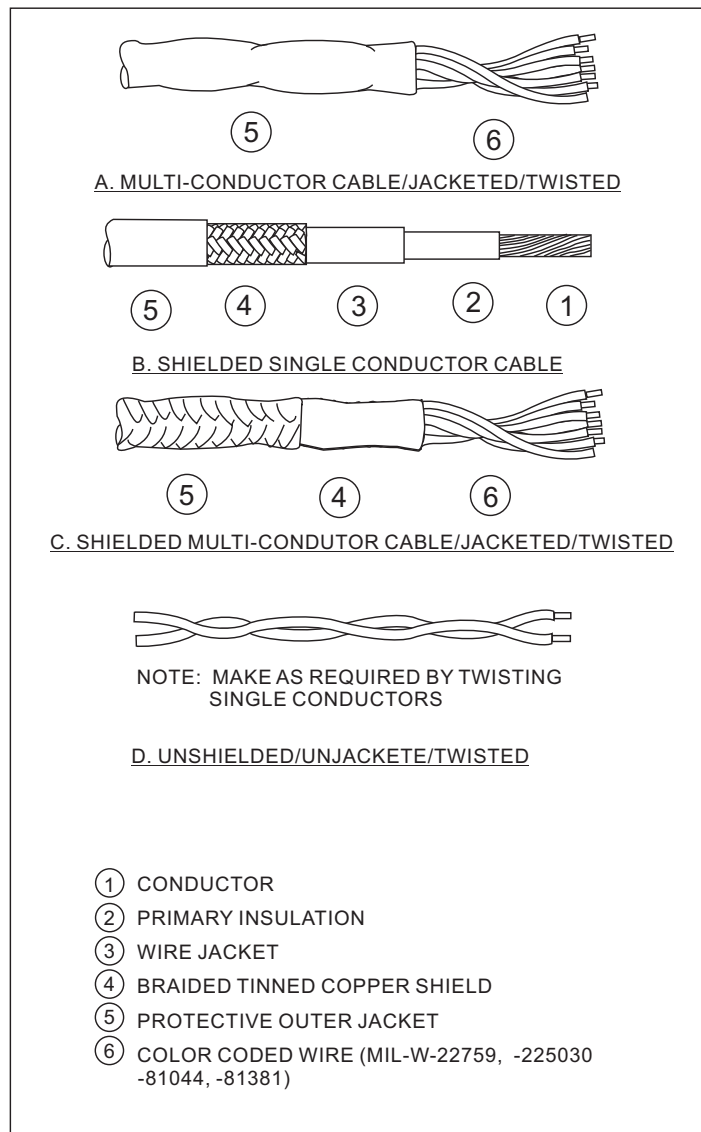

AEf05010

**Figure 5-10.—Cables commonly used in aircraft.**

- Jacketed wires with an overall jacket
- Shielded and jacketed one to seven wires with one or two shields within an overall jacket

### Wire and Cable Identification

To make aircraft maintenance easier, each connecting wire or cable in an aircraft has identification marked on it. The identification is a combination of letters and numbers. The marking identifies the circuit that the wire or cable belongs to, the gauge size of the wire or cable, and the information that relates the wire or cable to a wiring diagram. This marking uses the wire or cable identification code. You can find details of the wire and cable identification system in

*Military Specification: Wiring, Aerospace Vehicle, SAE-AS50881.*

### Wiring and Cable Identification Codes

The block of wire numbers for each item of equipment starts with the number *1* and continues for as many numbers as needed to identify all wires. If a military type designation (AN [Air Force-Navy] nomenclature) is **not** assigned for a piece of equipment, such as with commercial equipment, get a block of numbers from the procuring activity. To get the wire identification code for equipment with military type (AN nomenclature) equipment designation, use that portion of the equipment designation that follows the slash on AN equipment and exclude the hyphen and

suffix letter. The following are wire-coding examples for military type equipment:

Equipment	Wire Code
AN/APS-45	APS45-1A20-APS45-975C22
AN/ARC-52A	ARC52-1A22-ARC52-9C22
MX-94	MX94-1A20

**NOTE:** For an in-depth study of aircraft wiring specifications, limitations, and repair, refer to NAVAIR 01-1A-505.

The basic wire identification code for circuits is read from left to right. Refer to figure 5-11.

Use prefix *unit numbers* 1, 2, 3, 4, and so forth where two or more identical items of equipment are in the same aircraft to differentiate between wires or cables for each item of equipment. To make it easier to interchange items, identical wiring or cable is located in left and right wings, nacelles, and major interchangeable structural assemblies without using the unit number. For equipment with circuit function letters *R, S, T, or Y*, use the unit number only where complete duplicate equipment is installed. Unit numbers don't

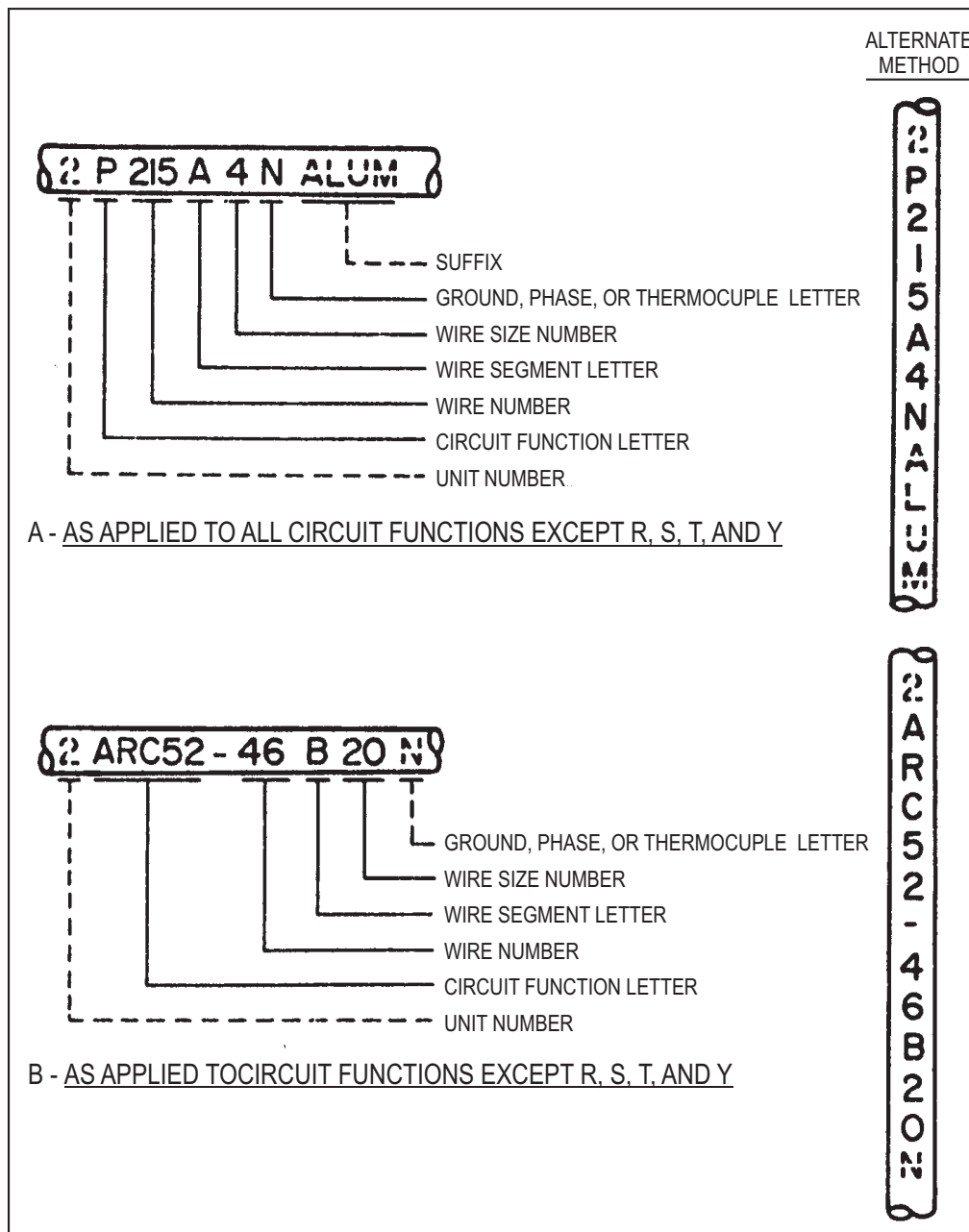

AEf05011

Figure 5-11.—Examples of wire identification coding.



apply to duplicate components within single complete equipment such as duplicate indicators or control boxes.

The *circuit function letter* identifies the circuit function (table 5-3B). When using a wire or cable for more than one circuit function, use the circuit function letter of the predominant circuit. When functional predominance is questionable, use the circuit function letter for the wire or cable having the lowest wire number. Substitute the contractor-assigned “equipment identification” instead of the circuit function letter for equipment that has an *R*, *S*, *T*, or *Y* circuit function.

The *wire number* identifies the different wires in a circuit and consists of one or more digits. A different number is used for wire not having a common terminal or connection as follows:

- Wires with the same circuit function with a common terminal connection or junction have the same wire number but different segment letters.
- Assign a number to each wire in numerical sequence beginning with the lowest number when practical.

**Table 5-3B.—Wiring Circuit Function Codes**

Circuit function letter	Circuits
A	Armament
B	Photographic
C	Control surface
D	Instrument (other than instrument & flight)
E	Engine instrument
F	Flight instrument
G	Landing gear, wing folding
H	Heating, ventilating, and de-icing
J	Ignition
K	Engine control
L	Lighting
M	Miscellaneous (electrical)
P	Dc power
Q	Fuel and oil
R	Radio (navigation and communication)
S	Radar (pulse technique)
T	Special electronic
U	Miscellaneous (electronic)
V	Dc power cables and dc control cables for ac systems
W	Warning and emergency
X	Ac power
Y	Armament special systems
Z	Experimental circuits

A *wire segment* is a conductor between two terminals or connections and identifies different conductor segments in a particular circuit. Use a different letter for wire segments having a common terminal or connection. Wire segment letters are in alphabetical sequence. The letter *A* identifies the first segment of each circuit starting at the power source. If a circuit contains only one wire segment, this wire segment is *A*. Do not use the letters *I* or *O* as segment letters. Use double letters *AA*, *AB*, *AC*, and so forth when there are more than 24 segments. Two permanently spliced wires do not require separate segment letters if the splice is for modification or repair.

The *wire size number* identifies the size of the wire or cable. Do not include the wire size for coaxial cables and thermocouple wires. For thermocouple wires, use a dash (-) instead of the wire size number.

**NOTE:** Stranded conductor wire is used for flexibility in installation and service. Although aircraft wire sizes approximate American Wire Gage (AWG) wire size, aircraft wire sizes vary enough from AWG wire sizes for it to be improper to refer to aircraft wire size as AWG.

Use the *ground*, *phase* or *thermocouple* letter as follows:

- Ground cable letter *N* is a suffix to the wire identification code. It identifies any wire or cable that completes the circuit to the ground network. Such wires and cables connect to the ground network of aircraft electrical systems without causing any circuit malfunctions. For electronic systems with interconnecting ground leads, but only one segment actually grounded to structure, *N* identifies the segment actually grounded to the structure.
- Phase letter *A*, *B*, or *C* is a suffix on the wire identification code. It identifies the phase or wires in the three-phase power ac distribution systems. The phase sequence is *A*→*B*→*C*.
- Phase letter *V* is a suffix on the cable identification code. It identifies the ungrounded wire or cable in a single-phase system.
- For thermocouple wire, use the following suffixes:

CHROM—Chromel®  
ALML—Alumel®  
IRON—Iron  
CONS—Constantan  
COP—Copper

**NOTE:** Chromel® and Alumel® are registered trademarks of Hoskins Manufacturing Company.

Add the *suffix* ALUMINUM or ALUM to the identification code (when required) when using aluminum wire.

## Wire Marking

You may stamp the identification code on wires either horizontally or vertically as shown in figure 5-11. Stamping the identification marking directly on the wire or cable with a hot foil-stamping machine is the preferred method. Use this method wherever possible. If the wire insulation or outer covering won't stamp easily, stamp lengths of insulating tubing (sleeves) with the identification marking. Then, install the sleeve on the wire or cable. The following types of wire usually have sleeve identification markings:

- Unjacketed shielded wire
- Thermocouple wire
- Multiconductor cable
- High-temperature wire with insulation difficult to mark, such as TFE, fiberglass, and so forth

### CAUTION

DO NOT use metallic markers or bands for identification.

DO NOT use any method of marking that will damage or deform the wire or cable.

Use the following guidance with whatever method you use to mark the wire:

- Make sure the marking is legible and the color contrasts with wire insulation or sleeving.
- Use black stamping for light-colored backgrounds and white on dark-colored backgrounds.
- Make sure that markings are dry so they don't smear.
- **Stamp wires and cables at intervals of not more than 15 inches along their entire lengths** (fig. 5-12).
- Stamp wires within 3 inches of each junction (except permanent splices) and at each ending point.

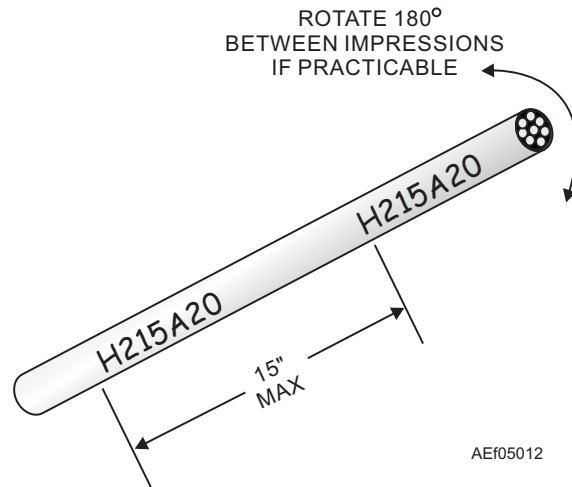

Figure 5-12.—Spacing of identification stamping on wire and cable.

- Stamp 3- to 7-inch-long wires in the center.
- You don't need to stamp a wire if it is less than 3 inches long.

## WIRING INSTALLATION

Wiring installation has the following order of precedence:

1. Safety of flight
2. Ease of maintenance
3. Cost effectiveness

Safety of flight is always the prime concern in maintenance and must not be compromised by anyone for any reason.

Ease of maintenance means that wire should be installed to meet the following criteria:

- Maximum reliability
- Minimum interference and coupling between systems
- Accessibility for inspection
- Accessibility for maintenance
- Prevention of damage

The cost effectiveness pertains to the contractor but also depends upon correct maintenance practices.

## Routing Wires

Install wiring so that it is mechanically and electrically sound and neat in appearance. Route wiring to assure reliability and offer protection from the following hazards:

- Chafing
- Use as handholds or as support for personal equipment
- Damage by personnel
- Damage by stowage or shifting of cargo
- Damage by battery or acid fumes and fluids
- Abrasion in wheel wells where exposed to rocks, ice, mud, and so forth
- Combat damage (to the maximum extent possible)
- Damage by moving parts
- Harsh environments such as swamp areas, high temperatures, or areas susceptible to significant fluid or fume concentration

## Slack in Wiring

Install wiring to provide enough slack to prevent strain on wires and to permit access to equipment during maintenance. When terminating wiring in a connector (excluding RF connectors), provide at least 1 inch of slack for complete connector replacement. Place slack between the connector and the second wiring support clamp. The 1-inch slack requirement means that with the connector unmated and the first wiring support clamp loosened, the wiring will permit the front end of the connector shell to extend 1 inch beyond the point normally required to properly mate the connector. At each end of a wire terminated by a lug, provide a minimum length of slack equal to twice the barrel length of the lug. For copper wire, size 2 AWG and larger, and aluminum wire, size 4 AWG and larger, the minimum length of slack should be equal to

one barrel length of the lug. The slack must be in the vicinity of the lug and available for replacement of the lug by maintenance personnel.

### Tying and Lacing Wire Groups and Bundles

A *wire group* is two or more wires tied or laced together to give identity to an individual system. A *wire bundle* is two or more wires or groups tied or laced together to provide easier maintenance. *Tying* is the securing together of a group or bundle of wires by individual pieces of cord tied around the group or bundle at regular intervals. *Lacing* is the securing together of wires inside enclosures by a continuous piece of cord, forming loops at regular intervals around the wire group or bundle.

Tie or lace wire groups and bundles together. This makes it easier to install, maintain, and inspect them. Also, it keeps the cables neatly secured in groups and bundles to help avoid damage from chafing or equipment operation.

Wherever possible, use a narrow, flat, non-adhesive tape for tying and lacing. You may use round cord; however, it has a tendency to cut into wire insulation. Use cotton, linen, nylon, or glass fiber cord or tape, according to the temperature requirements. Pre-wax cotton or linen cord or tape to make it moisture- and fungus-resistant. Nylon cord or tape may be waxed or unwaxed. Glass fiber cord or tape is usually not waxed.

**PRECAUTIONS FOR TYING AND LACING WIRE GROUPS.**—When tying and lacing wire groups and bundles, use the following precautions:

- Tie or lace bundles tightly enough to prevent slipping, but not so tightly that the cord cuts into or deforms the insulation. This applies especially to coaxial cable, which has a soft

dielectric insulation between the inner and outer conductors.

- DO NOT place ties on that part of a wire group or bundle located inside a conduit.
- Lace wire groups or bundles only inside enclosures, such as junction boxes.
- Use double cord on groups or bundles larger than 1 inch in diameter. Use single or double cord for groups or bundles 1 inch or less in diameter.

**NOTE:** Coaxial cables can be damaged from lacing materials or methods of lacing or tying wire bundles that cause a concentrated force on the cable insulation. Elastic lacing materials, small-diameter lacing cord, and excessive tightening deform the inner conductor insulation, which may result in short circuits or impedance changes. Flat, nylon, braided, waxed lacing tape is recommended for coaxial cables.

**PROCEDURES FOR LACING WITH A SINGLE CORD.**—Use the following procedures to lace a wire group or bundle with a single cord:

1. Start the lacing at the thick end of the wire group or bundle with a knot consisting of a clove hitch with an extra loop. See figure 5-13.
2. At regular intervals along the wire group or bundle and at each point where a wire or wire group branches off, continue the lacing with half hitches. Space half hitches so the group or bundle is neat and securely held.
3. End the lacing with a knot consisting of a clove hitch with an extra loop.
4. Trim the free ends of the lacing cord to three-eighths inch minimum.

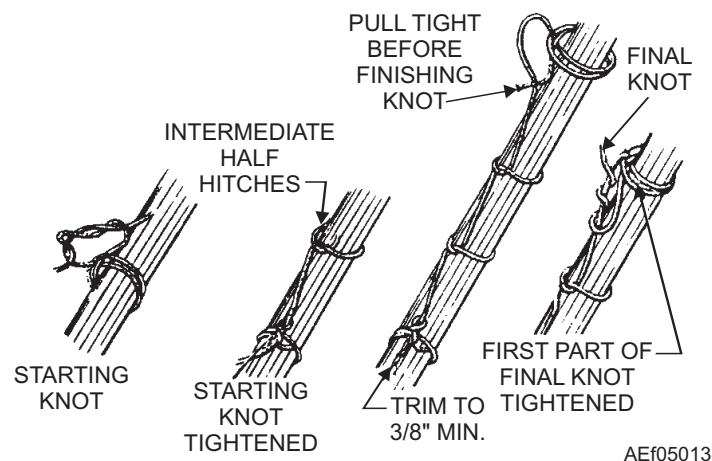
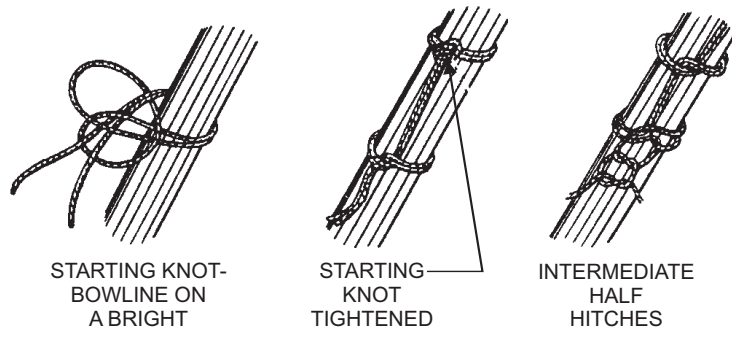

Figure 5-13.—Single-cord lacing.



AEf05014

Figure 5-14.—Double-cord lacing.

**PROCEDURES FOR LACING WITH A DOUBLE CORD.**—Use the following procedures to lace a wire group or bundle with a double cord:

1. Start the lacing at the thick end of the wire group or bundle with a bowline on a bight. See figure 5-14.
2. At regular intervals along the wire group or bundle and at each point where a wire group branches off, continue the lacing with half hitches, holding both cords together. Space half hitches so the group or bundle is neat and securely held.
3. End the lacing with a knot consisting of a half hitch, using one cord clockwise and the other

counterclockwise, and then tie the cord ends with a square knot.

4. Trim the free ends of the lacing cord to three-eighths inch minimum.

**PROCEDURES FOR LACING A BRANCHING WIRE GROUP.**—Use the following procedures to lace a wire group that branches off the main wire bundle:

1. Start the branch-off by lacing with a starting knot located on the main bundle just past the branch-off point. See figure 5-15. When using single-cord lacing, make the starting knot the same as regular single-cord lacing. When using double-cord lacing, use the double-cord lacing starting knot.

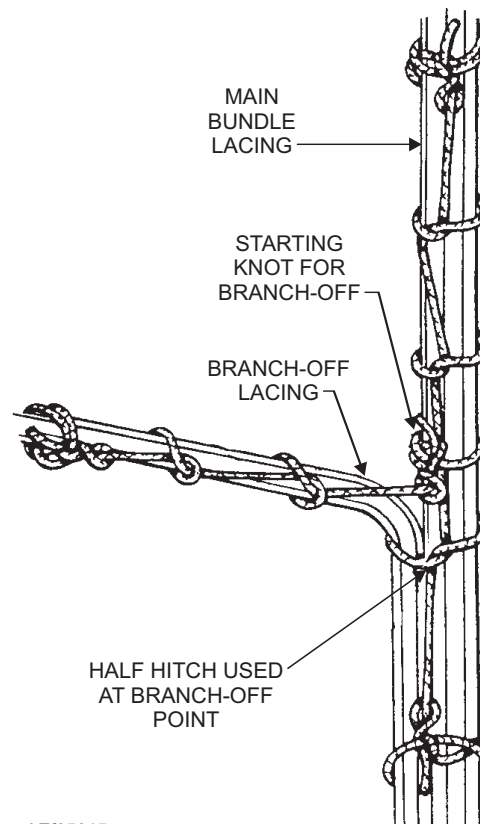

AEf05015

Figure 5-15.—Lacing a branch-off.

2. End the lacing with the regular knot used in single- and double-cord lacing (for single-cord lacing, a clove hitch with a single loop; for double-cord lacing, a half hitch, using one cord clockwise and the other counterclockwise, then tied with a square knot).
3. Trim the free ends of the lacing cord to three-eighths inch minimum.

**TYING WIRE GROUPS WHEN SUPPORTS ARE MORE THAN 12 INCHES.**—Tie all wire groups or bundles (fig. 5-16) when supports are more than 12 inches apart. Space the ties so they are 12 inches or less apart. To make a tie, use the following procedures:

1. Wrap cord around wire group or bundle, as shown in figure 5-16, view A.
2. Make a clove hitch followed by a square knot with an extra loop.
3. Trim free ends of cord to three-eighths inch minimum.

**TYING SLEEVES TO WIRE GROUPS OR WIRE BUNDLES.**—When tying sleeves to wire groups or wire bundles, make the ties the same as for wire groups and bundles (use a clove hitch followed by a square knot with an extra loop).

### Tape

When it is permissible to use tape, use the following method:

1. Wrap tape around the wire group or bundle three times, with a two-thirds overlap for each turn. See figure 5-16, view B.

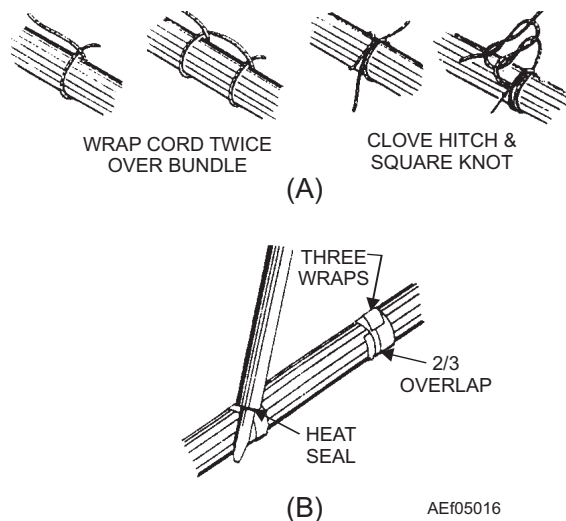

Figure 5-16.—Tying groups or bundles.

2. Heat-seal the loose tape end with the side of a soldering iron heating element.

DO NOT use tape to secure a wire group or bundle that requires frequent maintenance.

**USING SELF-CLINCHING CABLE STRAPS.**—Self-clinching cable straps are adjustable, lightweight, flat nylon strips. See figure 5-17, view A. They have molded ribs or serrations on the inside surface to grip the wire. You may use them instead of individual cord ties for quickly securing wire groups or bundles. The straps are of two types—a plain cable strap and one that has a flat surface for identification of cables.

### CAUTION

DO NOT use nylon cable straps over wire bundles containing coaxial cable.

DO NOT use straps in areas where failure of the strap would allow the strap to fall into movable parts.

Installing self-clinching cable straps is done with a military standard hand tool as shown in figure 5-17, view B. Follow the manufacturer's instructions when using the tool.

### WARNING

Use proper tools and make sure the strap is cut flush with the eye of the strap. This prevents painful cuts and scratches caused by protruding strap ends.

DO NOT use plastic cable straps in high-temperature areas (above 250°F).

### Heat-Shrinkable Tubing

Heat-shrinkable tubing is a plastic-like tubing (similar to insulation sleeving) that will shrink to a smaller diameter when heated. Place the tubing over the joint, terminal, or part needing insulation. Now apply heat with a heat gun, oven, or other heat source. When the tubing reaches a specific temperature (shrink temperature depends upon the type of tubing), it quickly shrinks around the object, forming a snug jacket. In addition to being an insulator, the shrinkable tubing helps relieve strain and adds waterproofing. Figure 5-18 gives some of the typical uses of heat-shrinkable tubing.

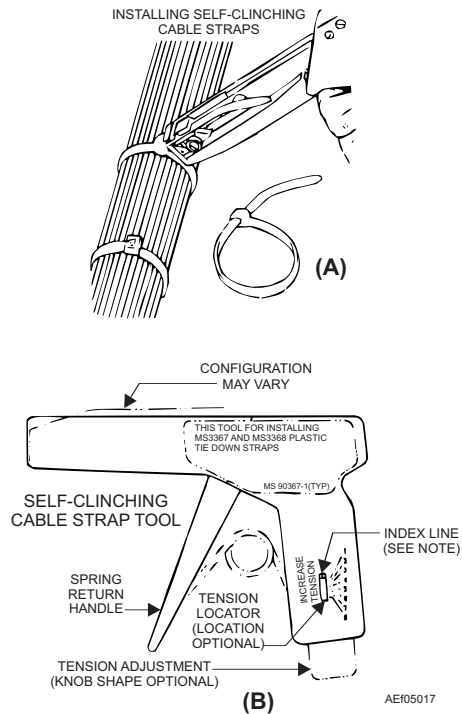

Figure 5-17.—Installing self-clinching straps.

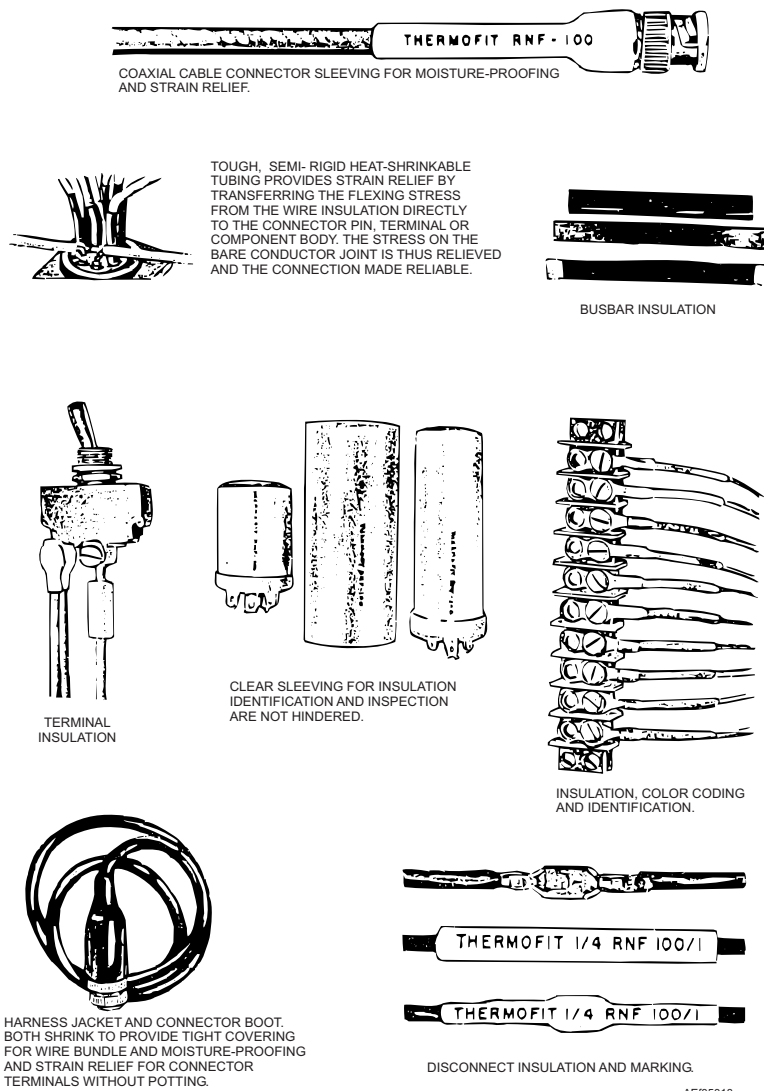

Figure 5-18.—Typical heat shrinkable tubing.

## Cable Stripping

Nearly all wire and cable electrical conductors have some type of insulation. When making electrical connections with wire, you must remove a part of this insulation, leaving the end of the wire bare. To help you remove insulation, use a wire and cable-stripping tool similar to the one shown in figure 5-19.

The operation of this basic tool is efficient and simple. To operate it, insert the wire end in the proper direction and depth to be stripped. Now position the wire so it rests in the groove for the size wire being stripped and squeeze.

- Q5-24. *Where should you first look for wire replacement information?*
- Q5-25. *What type wire should you use to carry 600-1000 volts with a temperature rating between 302°F to 500°F?*
- Q5-26. *When stamping wire identification numbers, at what interval should you stamp the wire?*
- Q5-27. *In wire identification numbers, what does the suffix N mean?*
- Q5-28. *When wiring is terminated with a connector, what is the minimum slack that should be provided?*
- Q5-29. *Why is flat, nylon, braided, waxed lacing tape preferred for tying coaxial cables?*
- Q5-30. *What is the purpose of heat shrink tubing?*

## AIRCRAFT AND EQUIPMENT HARDWARE

**LEARNING OBJECTIVES:** Recognize aircraft hardware and equipment hardware and their uses in aircraft maintenance.

The hardware you should use when installing electrical equipment in aircraft is specified in the applicable MIM. Some of the types of hardware discussed in this section include electrical connectors, conduit and fittings, junction boxes, safety wiring, shock mounts, and bonding.

You should always use proper parts, but you shouldn't always use the same mounting parts that you removed from the installation. Before reusing a part, inspect it to make sure it isn't defective or damaged. Also check the instructions; some parts can't be reused. If you need to substitute a part, make sure the substitute part is satisfactory. *Aircraft Structural Hardware for Aircraft Repair*, NAVAIR 01-1A-8, and *Installation Practices, Aircraft Electric and Electronic Wiring*, NAVAIR 01-1A-505, are sources of detailed information.

If you can't get a mounting part specified by the IPB for the electrical equipment, you may make a temporary installation using a suitable substitute part. Replace the part with the item specified by the IPB as soon as you receive it. Always check with your work center supervisor before you make a substitution. When making part substitutions, you should give special consideration to the factors in table 5-4.

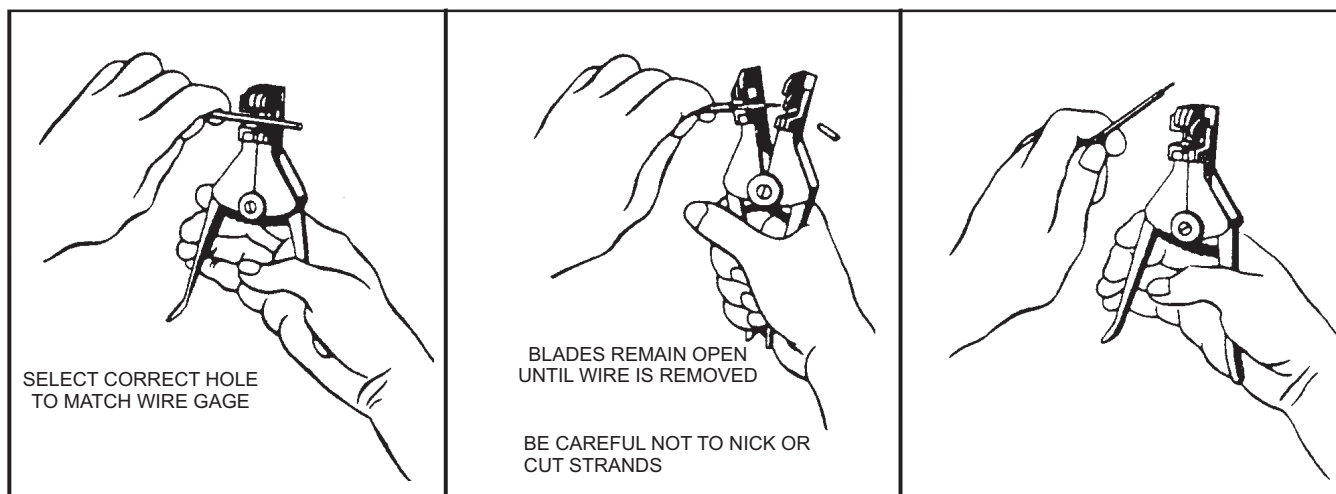

AEF05019

Figure 5-19.—Wire stripping method.



**Table 5-4.—Factors To Consider When Making Part Substitutions**

FACTORS	CONSIDERATIONS
Corrosion	<ul style="list-style-type: none"> <li>• Pay attention to the chemical or metallic composition of the part.</li> <li>• Choose a part that doesn't contribute appreciably to the danger of corrosion.</li> </ul>
Strength	<ul style="list-style-type: none"> <li>• The strength of the substitute part must be the same or greater than the one prescribed. (When determining the strength, consider the tensile, compression, and shear strength, as applicable to the specific use.)</li> </ul>
Size	<ul style="list-style-type: none"> <li>• Substitute nuts, bolts, and screws should be the same size as the prescribed item.</li> <li>• Washers must have the same inner diameter as the prescribed item. A different outer diameter or thickness is acceptable.</li> </ul>
Length	<ul style="list-style-type: none"> <li>• The length of substitute screws or bolts must be enough for the particular installation. However, length can't be long enough to interfere with any moving part.</li> <li>• Hardware shouldn't come in contact with other aircraft items, such as electrical wiring, hydraulic lines, and so forth.</li> </ul>
Magnetic properties	<ul style="list-style-type: none"> <li>• Equipment installed in specific areas of the aircraft shouldn't cause distortion of the magnetic fields of the area. Examples of such items include the magnetic compass, magnetic anomaly detection equipment, radio direction finder, or gyros. In areas containing these types of equipment, any substitute part must have the same magnetic properties and characteristics as the one prescribed.</li> </ul>
Style	<ul style="list-style-type: none"> <li>• Most items of mounting hardware are available in various styles. It is usually easy to find screws and bolts that are the same in all respects except the type head. Use these parts as substitutes when they have the required special features.</li> </ul>
Special features	<ul style="list-style-type: none"> <li>• If a bolt requires torque to a given value, a suitable torque wrench for that type part must be available.</li> <li>• If the MIM calls for lock wire, the part must have suitable provisions for lock wire.</li> </ul>
Lubrication or coating	<ul style="list-style-type: none"> <li>• If specific instructions call for lubrication or coating of the parts, follow those instructions for the substitute part as well as for the prescribed part.</li> </ul>

## ELECTRICAL CONNECTORS

In this section, the word *connector* is used in a general sense. It applies to electrical connectors with Air Force-Navy (AN) numbers and those with military specification (MS) numbers. The Air Force and Navy formerly used AN numbers for all supply items cataloged jointly. Many items, especially those of older design, still carry the AN designator. The supply system is shifting to MS numbers.

### Connector Function

Electrical connectors provide detachable coupling between major components of electrical and electronic

equipment. These connectors are built to withstand the extreme operating conditions imposed by airborne service. They must make and hold electrical contact without excessive voltage drop despite extreme vibration, rapid shifts in temperature, and changes in altitude.

### Moisture-proof Connector Use

Present Navy practice is to use potted connectors (moisture-proof or environment-proof connectors). All jet- and carrier-type aircraft have potted connectors. Other aircraft need moisture-proofing sealant on electrical connectors in areas where a chance of failure exists. Connectors in wheel wells, wing fold areas,

engine areas, engine nacelles, or cockpit decks have a high chance of failure and are sealed in addition to connectors that interconnect flight and basic navigation equipment. Moisture proofing reduces electrical connector failures by reinforcing the wires against vibration and lateral pressure at the solder cup. The sealing compound also protects electrical connectors from corrosion and contamination by excluding metallic particles, water moisture, and aircraft liquids and results in better dielectric characteristics that reduce chance of arc-over between pins.

### Connector Design

Connectors consist of two portions—the fixed portion, called the *receptacle*, and the movable portion, called the *plug*. Plug assemblies may be straight or angled (usually 90 degrees). Receptacle assemblies may be of the wall-mounted, box-mounted, or integral-mounted types. MS numbers and letters identify the type, style, and arrangement of a connector.

Connectors vary widely in design and application. A coupling nut or ring holds the two assemblies firmly together. The assembly consists of an aluminum shell containing an insulating insert, which holds the current-carrying contacts. The plug usually attaches to the cable end and is the part of the connector on which the coupling nut mounts. The receptacle is the half of the connector to which the plug connects. The receptacle is usually mounted on a part of the equipment.

In naval aircraft, connectors with crimp-type contacts are widely used. Maintenance is easier because you can remove the contact from the connector. If the connector is damaged, you can remove the contacts and replace the connector shell. If just a connector pin is damaged, you can remove and replace the pin. This is a considerable advantage over the solder-type connector, both in convenience and timesavings. A discussion of the special tools you need to remove and insert crimped contacts is contained in *Installation Practices, Aircraft Electric and Electronic Wiring*, NAVAIR 01-1A-505.

Some common types of subminiature connectors are shown in figure 5-20. They are used on instruments, switches, transformers, amplifiers, relays, and so forth.

### CONDUIT AND FITTINGS

In many aircraft, the use of conduit (pipe or tubing) for electrical wire or cable is limited. This practice saves weight and ensures wide separation of wire or

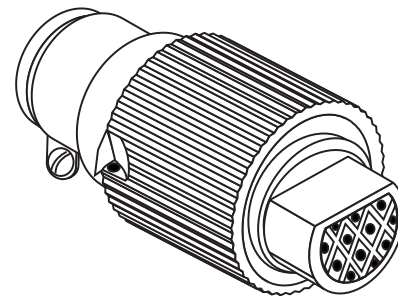

PLUG WITH SOCKET INSERT

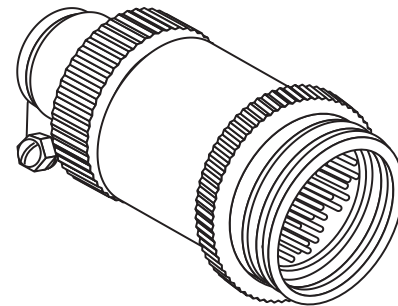

PLUG WITH PIN INSERT

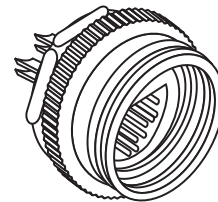

RECEPTACLE WITH INSERT

AEf05020

Figure 5-20.—Subminiature connectors.

cables. The separation of the electrical system makes it less vulnerable to gunfire. However, some current aircraft, especially those with limited space for wire routing, use conduit. Some examples of conduit and fittings are shown in figure 5-21.

Conduit comes in two basic types—flexible and rigid. Its chief functions are to act as radio shielding and as a support and protection for wires.

Conduit fittings attach conduit to junction boxes and other equipment, and usually include ferrules and coupling nuts. Various forms of both are in use along with special designs of locknuts, box connectors, and coupling adapters.

Couplings for conduit are straight or angular in design. A ferrule is a bushing or flange applied to the end of conduit to give greater strength and support to the coupling nuts. A bushing or flange is crimped or swaged on conduit with a crimping or swaging tool.

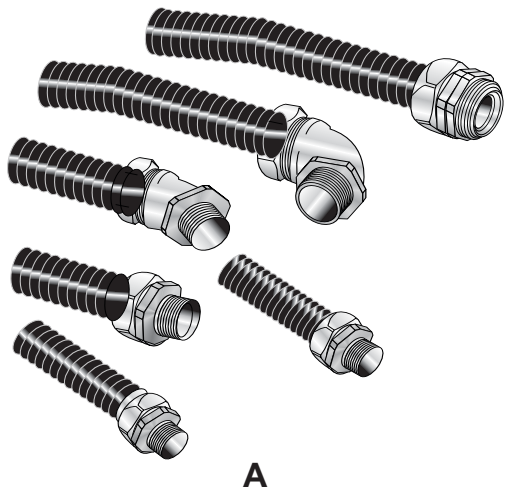

**A**

**B**

Figure 5-21.—Conduit and fittings.

## SUPPORT CLAMPS

Clamps provide support for conduit and open wiring and serve as lacing on open wiring. A clamp usually has a rubber cushion or is of all-plastic construction. When used with shielded conduit, the clamp is of the bonded type (fig. 5-22), that is, there is a provision for electrical contact between the clamp and conduit. Use unbonded clamps for the support of open wiring.

Long cable runs between panels need the use of a strap-type clamp (fig. 5-23, view A) or an AN 742 cable clamp (fig. 5-23, view B). The preferred method for supporting cable runs of all types is using AN 742 cable clamps. MS 25281D plastic clamps are for use where the maximum temperature does not exceed 250°F. When using the strap-type clamp, you must make sure

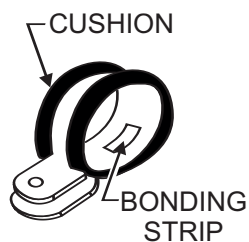

AEf05022

Figure 5-22.—Bonded-type cable clamp.

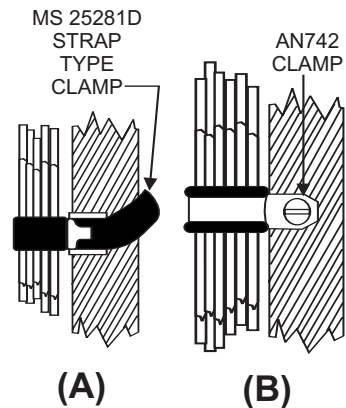

(A) (B)

AEf05023

Figure 5-23.—(A) Strap type cable clamp and (B) AN 742 cable clamp.

the clamps hold the cable firmly away from lines, surface control cables, pulleys, and all movable parts of the aircraft. Use these clamps only as a temporary measure. Replace with a permanent installation as soon as possible.

When cables pass through lightening holes, the installation should conform to the examples shown in figure 5-24. In each case, the AN 742 cable clamp holds the cable firmly. Route the cable well in the clear of the edges of the lightening hole to avoid chance of chafing the insulation. If wires are closer than one-fourth inch to the edge of the lightening hole, use a grommet (a rubber cushion) to protect the wires.

Protect wire bundles from the following:

- High temperature
- Battery acid fumes, spray, or spillage
- Solvents or fluids
- Abrasion in wheel wells where exposed to rocks, ice, or mud
- Damage due to personnel using the wire bundle as handholds or footsteps
- Damage due to shifting cargo

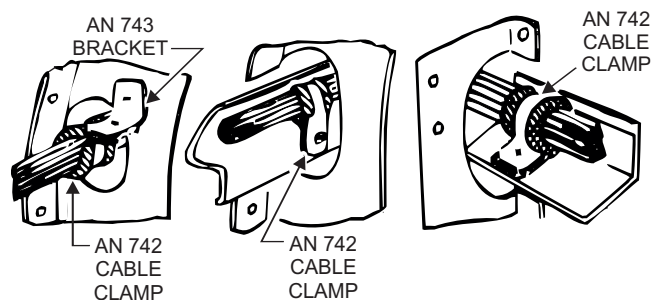

AEf05024

Figure 5-24.—Routing cables through lightening holes.

**Never** support any wire or wire bundle from a plumbing line carrying flammable fluids or oxygen. Use clamps on these lines only to ensure separation of the wire bundle from the plumbing line. Whenever possible, route wires and bundles parallel with or at right angles to the stringers or ribs of the area involved, as seen in figure 5-25.

Don't install single wires or wire bundles with excessive slack. Slack between support points, such as cable clamps, should not normally exceed one-half inch. (This is the maximum you should be able to deflect the wire with moderate hand force.) You may exceed this slack if the wire bundle is thin and the clamps are far apart. The slack must never be so large that the wire bundle can touch any surface. Allow a sufficient amount of slack near each end for the following reasons:

- To permit ease of maintenance
- To allow replacement of terminals at least twice
- To prevent mechanical strain on the wires, cables, junctions, and supports
- To permit free movement of shock- and vibration-mounted equipment
- To permit shifting of installed equipment for purposes of maintenance

## TERMINALS

Since most aircraft have stranded wires, you use terminal lugs to hold the strands together and make it easier to fasten wires to terminal studs. The types of terminals used in electrical wiring are either soldered or crimped. Terminals used in repair work must be the size and type specified on the electrical wiring diagram for the model being maintained. You may use soldered- and crimped-type terminals interchangeably, but both must have the same amperage capacity and the same size hole in the lug.

The increased use of crimp-on terminals is, to a large degree, due to the limitations of soldered terminals. The quality of soldered connections depends upon the operator's skill. Such factors as temperature, flux, cleanliness, oxides, and insulation damage caused by heat contribute to defective connections. The crimp-on solderless terminals require relatively little operator skill. Another advantage is that the use of a crimping tool eliminates the necessity of supplying power to a soldering iron. This allows installing terminals in an aircraft with a minimum of time and effort. The connections are made more rapidly, are cleaner, and are more uniform. Because of the pressures exerted and the materials used, the crimped connection or splice (when properly made) has an electrical resistance that is less than that of an equivalent length of wire.

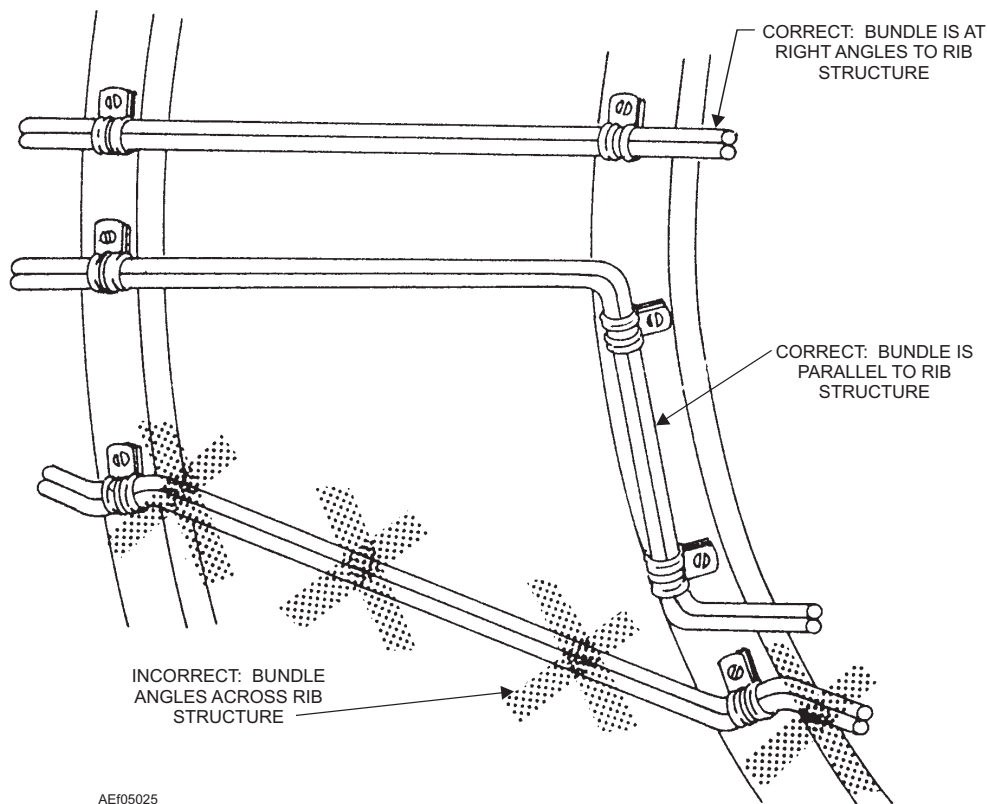

Figure 5-25.—Routing cables.

The basic types of terminals are shown in figure 5-26. View A shows the straight type, view B the right-angle type, view C the flag type, and view D the splice type. There are also variations of these types. Variations may include the use of a slot instead of a terminal hole, three- and four-way splice-type connectors, and others.

Since present-day aircraft have both copper and aluminum wiring, both copper and aluminum terminals are necessary. There are various size terminal and stud holes for each of the different wire sizes. A further refinement of the solderless terminals is the insulated type, where insulation encloses the barrel of the terminal. The crimping process compresses the insulation along with the terminal barrel but does not damage it in the process. This eliminates the need for taping or tying an insulating sleeve over the joint.

### Terminal Blocks

Terminal blocks, made from an insulating material, support and insulate a series of terminals from each other, as well as from ground. They provide a way to install terminals within junction boxes.

The two methods of attaching cable terminals to terminal blocks are shown in figure 5-27. View A uses a standard nonlocking nut. In this installation method, the use of a lock washer is necessary. View B shows the preferred method. When using an anchor nut, or self-locking nut, you omit the lock washer. The use of anchor nuts is especially desirable in areas of high vibration. In both installations, you must use a flat washer, as shown in the drawing.

The letters *TB* followed by the number of the individual board identify each terminal board in the aircraft electrical system. A number identifies each stud on the terminal board. The lowest number in the series starts at the end nearest the terminal board identification number. The identification number is on

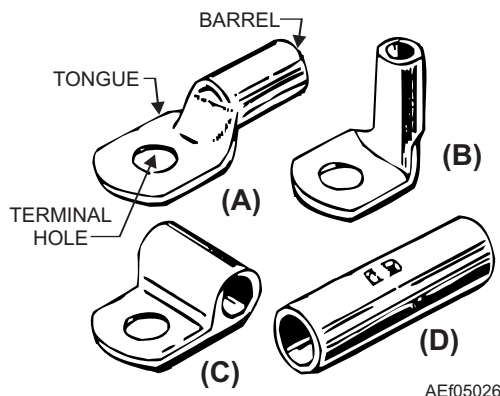

Figure 5-26.—Types of solderless terminals.

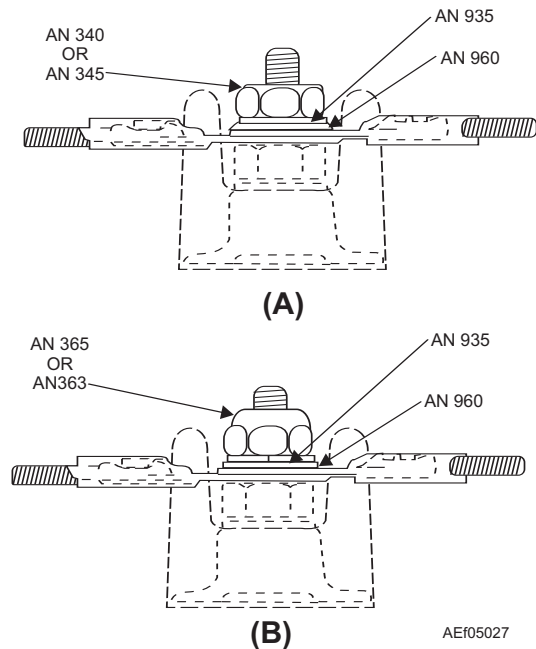

Figure 5-27.—Installation of cable terminals on terminal block.

the structure to which the terminal board attaches. It mounts on an identification strip cemented to the structure under the terminal board. When replacing a terminal board, **don't** remove the identification marking. If the identification marking is damaged, replace the marking with one that is the same as the original.

### Junction Boxes

Junction boxes accommodate electrical terminals or other equipment. Individual junction boxes are named according to their function, location, or equipment with which they are associated. Junction boxes have a drain hole (except boxes labeled *vapor tight*) at the lowest point to drain water, oil, condensate, or other liquids. Figure 5-28 shows a representative junction box for housing and protecting several terminal blocks.

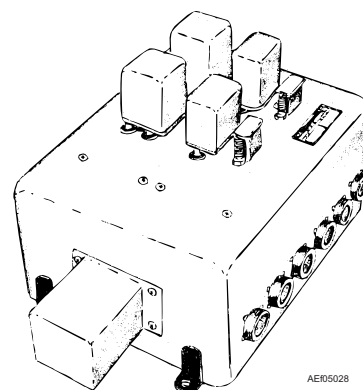

Figure 5-28.—Aircraft junction box.

When you install a junction box, make sure the screw or bolt heads are inside the box. Don't install attaching hardware so the threaded part of the screw or bolt protrudes inside the junction box. The sharp thread edges of protruding hardware may damage wire insulation.

## SAFETY WIRING

Some equipment parts require a positive safety-locking device. The use of safety wire is one accepted method of providing this safety measure. Two of the most common types of safety wiring are lock wire and shear wire. Lock wire and shear wire serve two complete and distinctly different purposes. Lock wire secures nuts, bolts, screws, and connectors from movement. Shear wire ties electrical switching devices in the OFF position.

### WARNING

Loss of life may occur when lock wire is used instead of shear wire. Under no circumstances shall lock wire and shear wire procedures and materials be mixed or interchanged.

### Lock Wire

*Lock wire*, also referred to as safety wiring, is used to prevent accidental loosening of aircraft equipment and connectors due to vibration. You should always use new safety wire on every job. Be careful to use pliers only on the ends of the wire so you don't nick the wire. If safety wire becomes nicked, discard it and use a new piece. NEVER back off or over-torque to align holes for safety wiring.

**DOUBLE-TWIST METHOD.**—The most common method of safety tying nuts, bolts, and screws is the *double-twist method*. You can do this by hand or with special safety wire pliers. (See fig. 5-29) If you make the twists in safety wire by hand without pliers, use pliers to make the final few twists so there is enough tension to secure the ends of the wire properly. Install and twist safety wire so that the loop around the head stays down and does not tend to come up over the bolt head. When you twist the safety wire together, be extremely careful to ensure it is tight, but do not overstress it to the point where the wire will break under a slight load or vibration. After you make the final twists of safety wire with pliers, cut off the nicked loose ends and bend the end of the wire around the bolt

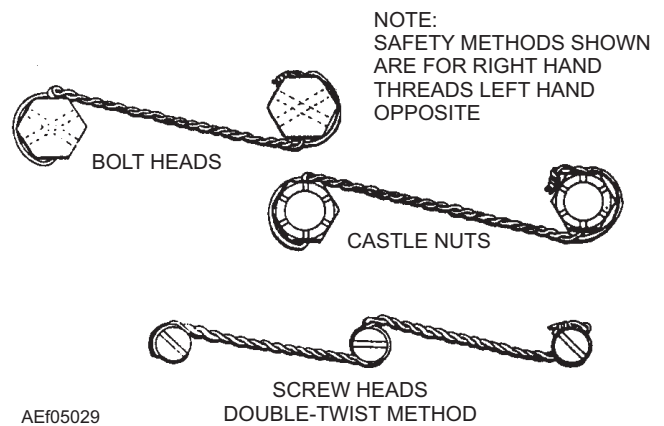

Figure 5-29.—Double-twist method of safety tying.

or screw head. This will protect personnel from the sharp ends.

**SINGLE-WIRE METHOD.**—You may use the *single-wire method* of safety wiring (fig. 5-30) on small screws in a closely spaced area provided the screws form a closed geometrical pattern. Note that any loosening tendencies will pull against the tension of the wire.

**SAFETY-WIRING CONNECTORS.**—Secure an electrical connector with safety wire only when specified on engineering drawings or when experience has shown that the connector will not stay tight. Electric connectors are usually safety-wired in engine nacelles, in areas of high vibration, and in locations not readily accessible for periodic maintenance inspection.

When you must safety-wire electrical connectors, you should use 0.032-inch-diameter safety wire wherever possible. On a small part with a 0.045-inch-nominal-diameter hole or smaller, use 0.020-inch-diameter safety wire. Sometimes the connector to be safety-wired does not have a wire hole. If there is no wire hole, remove the coupling nut and drill a No. 56 (0.045-inch-diameter) hole diagonally

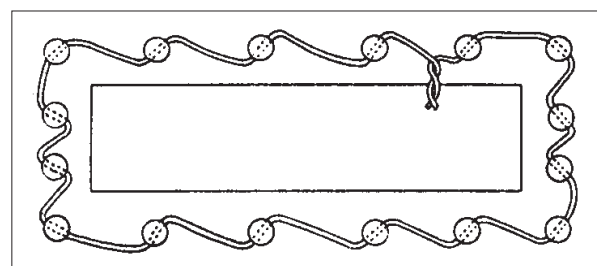

SMALL SCREWS IN CLOSELY SPACED CLOSED GEOMETRICAL PATTERN SINGLE-WIRE METHOD

AEf05030

Figure 5-30.—Single-wire method of safety wiring.

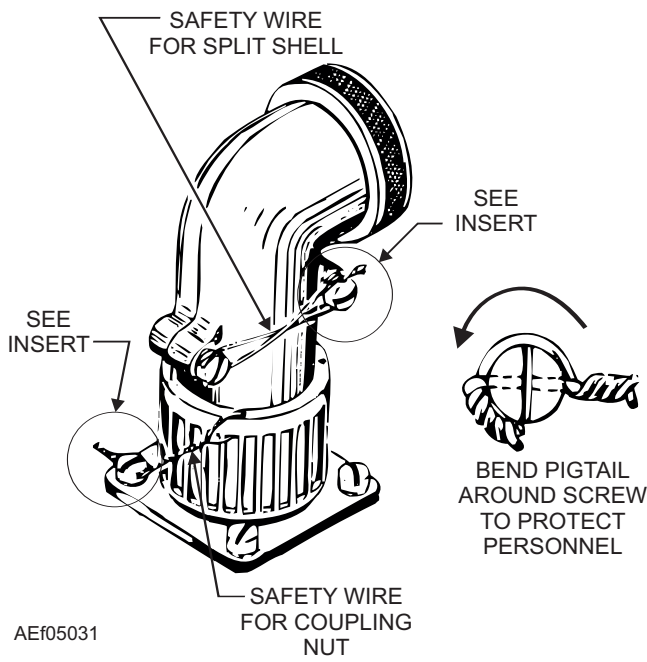

Figure 5-31.—Safety-wiring a connector.

through the edge of the nut. Figure 5-31 shows a safety-wired connector.

### Shear Wire

*Shear wire* is used for emergency device protection against accidental activation. An example of

safety-wiring a guarded switch is shown in figure 5-32. You can see that the wire is not twisted tightly. Use very soft wire; the wire may be either aluminum or copper. Shear wire lets the operator break the wire easily when necessary to engage the switch.

### SHOCK MOUNTS

Electronic equipment is sensitive to mechanical shock and vibration. Therefore, units of electronic equipment are normally shock mounted to provide some protection against in-flight vibration and against launching and landing shock. The specific type of prescribed shock mount will be in the MIM for the specific aircraft, and you should **not** use a substitute.

Shock mounts require periodic inspections. Replace any defective mounts as soon as possible. In the inspection, you should check for chemical decay of the shock-absorbing material, stiffness and resiliency of the material, and overall rigidity of the mount. If the mount is too rigid, it may not provide adequate protection against the shock of launching and landing. If it is not rigid enough, it may permit prolonged vibration following an initial shock. When determining the limits of rigidity and resiliency, you should consider the weight of the mounted unit as well as the possible amounts of positive and negative acceleration the unit may receive.

Shock-absorbing materials commonly used in shock mounts are usually electrical insulators. For

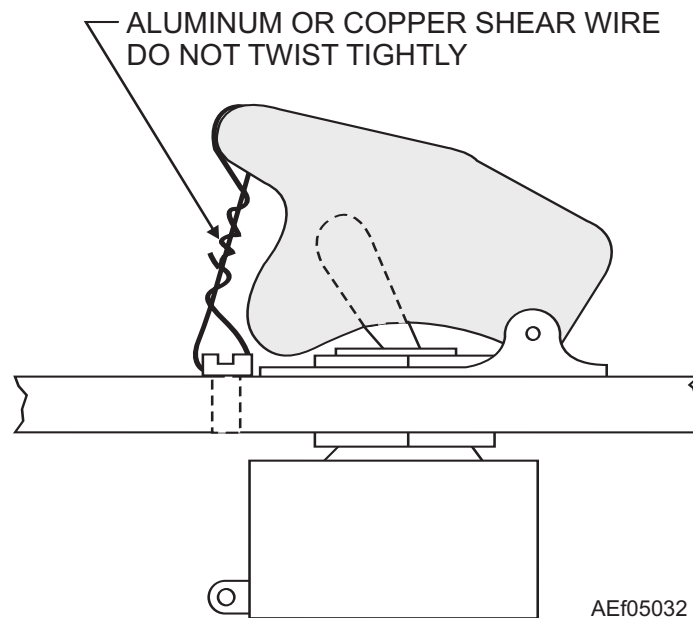

Figure 5-32.—Shear wire on a switch guard.

safety, each electronic unit mounted in this manner is electrically bonded to a structural member of the aircraft. Examples of two types of shock mounts are shown in figure 5-33. The inspection of the shock mounts should include the bonding straps. Replace or redo any defective or ineffective bonds straps.

## BONDING

A bond is any fixed union between two metallic objects that results in electrical conductivity between them. Such a union results either from physical contact between conductive surfaces of the objects or from the addition of a firm electrical connection between them. Aircraft electrical bonding is the process by which the necessary electrical conductivity between the component and metallic parts of the aircraft is gotten. An isolated conducting part of an object is one that is physically separate (by intervening insulation) from the aircraft structure and from other conductors bonded to the structure. A bonding connector provides the necessary electrical conductivity between metallic parts in an aircraft where electrical contact is insufficient.

## Reasons for Bonding

An aircraft can become highly charged with static electricity while in flight. In an improperly bonded aircraft, all metal parts will not have the same amount of charge, and a difference of potential will exist between various metal surfaces. Charges flowing through paths of variable resistance, such as moving control surfaces, will produce electrical disturbances (noise) in the radio receiver. If the resistance between isolated metal surfaces is large enough, charges can accumulate until the potential difference becomes high enough to cause a spark, creating a fire hazard. If lightning strikes an aircraft, a good conducting path is necessary for the heavy current. This reduces severe arcs and sparks, which would damage the aircraft and possibly injure its occupants.

The aircraft structure is also the ground for the radio. For the radio to function properly, a proper balance between the aircraft structure and antenna is required. This means the surface area of the ground must be constant. Control surfaces, for example, may at times become partially insulated from the remaining structure because of a film of lubricant on the hinges. This will affect radio operation if the condition is not taken care of by bonding.

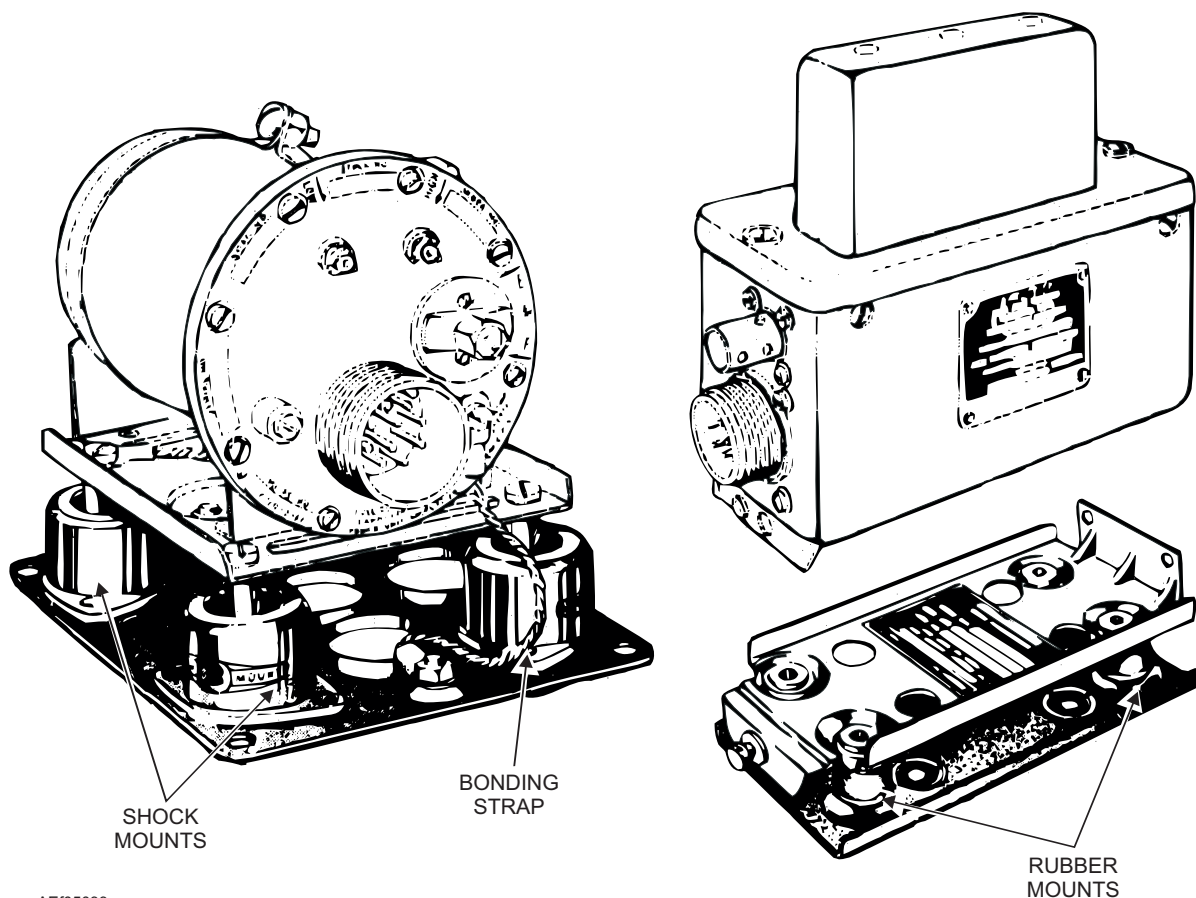

Figure 5-33.—Typical shock mounts.



Bonding also provides the necessary low-resistance return path for single-wire electrical systems. This low-resistance return path also aids the effectiveness of the shielding and provides a means of bringing the entire aircraft to the Earth's ground potential.

In summary, aircraft are electrically bonded for the following reasons:

- To reduce radio and radar interferences by equalizing static charges that accumulate
- To eliminate a fire hazard by preventing static charges from accumulating between two isolated members and creating a spark
- To reduce lightning damage to the aircraft and injury to its occupants
- To provide the ground for proper functioning of the aircraft radio
- To provide a low-resistance return path for single-wire electrical systems
- To aid in the effectiveness of the shielding
- To provide a means of bringing the entire aircraft to the Earth's potential, and keeping it that way while it is grounded to the Earth

## Bonding Methods

Bonding connections are made so vibration, expansion or contraction, or relative movement incidental to normal service use will not break the bonding connections. Bonding should not loosen to such an extent that the resistance would vary during the movement. The bonding of most concern is the bonding jumpers that go across shock mounts used to support electronic equipment. Examples of bonding connectors are bonding jumpers and bonding clamps. See figure 5-34.

Since a primary aim of bonding is to provide an electrical path of low dc resistance and low radio frequency (RF) impedance, the jumper should be a good conductor of ample size for the current-carrying capacity, have low resistance, and be as short as possible. If practical, you should bond parts directly to the basic aircraft structure rather than through other bonded parts. Install bonding jumpers so they do not interfere with the operation of movable components of the aircraft.

Contact of dissimilar metals in the presence of an electrolyte, such as salt water, produces an electric action (battery action) that causes a pitting in one of the metals. The intensity of this electric action varies with the kinds of metals. Frequently, bonding involves the direct contact of dissimilar metals. In such cases, the

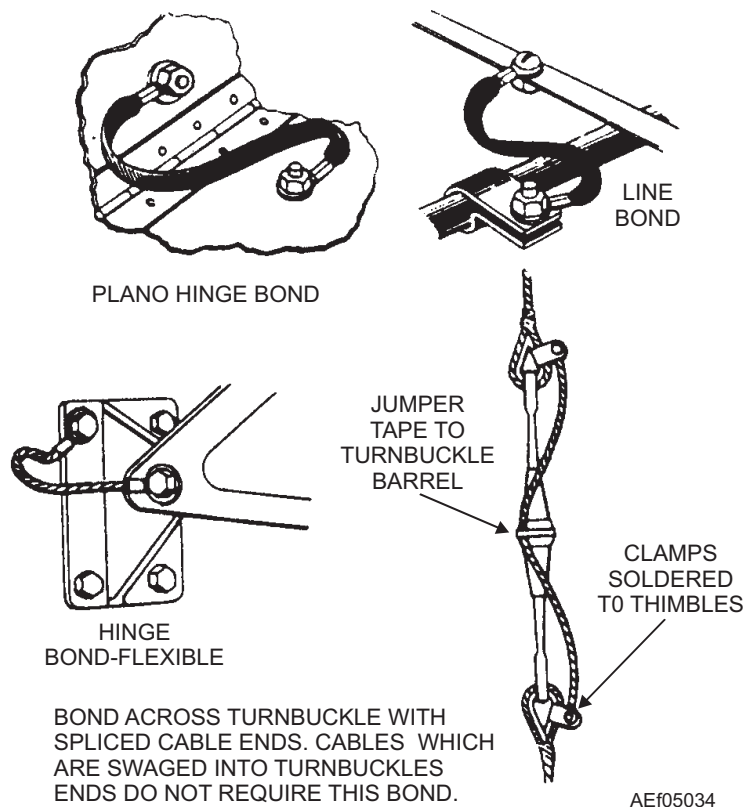

Figure 5-34.—Bonding methods.

metals used produce a minimum amount of corrosion. The connections also are made so that if corrosion does occur, it will be in replaceable elements, such as jumpers, washers, or separators, rather than the bonded or bonding members. Thus, use washers made of the same material as the structural member against the structural member. Also, use washers of the same material as the bonded member that is in contact with that item.

Self-tapping screws should not be used for bonding purposes, nor should jumpers be compression-fastened through plywood or other nonmetallic material. When performing a bonding operation, you should remove contact surface films before assembly, and then refinish the completed assembly with a suitable protective finish.

For more detailed information about bonding methods, you should refer to *Installation Practices, Aircraft Electric and Electronic Wiring*, NAVAIR 01-1A-505.

*Q5-31. What publication contains information on mounting hardware for aircraft parts?*

*Q5-32. When substituting hardware, what factors should you consider before making the substitution?*

*Q5-33. What is the only reason for clamping a wire bundle to a plumbing line?*

*Q5-34. What letters identify a terminal board?*

*Q5-35. What is the purpose of lockwire?*

## REPLACEABLE ASSEMBLIES

**LEARNING OBJECTIVES:** Recognize terms that are applicable to replaceable assemblies and subassemblies. Recognize tools to determine the maintenance level for repair of equipment.

Aircraft systems today are designed with a replaceable unit concept. Once the malfunction is isolated to the defective unit, simply replace the defective unit with a good one from supply. This design gives speed and economy to maintenance, as well as saving space and weight.

## WEAPONS AND SHOP REPLACEABLE ASSEMBLIES

Weapons replaceable assembly (WRA) is the term given to replaceable assemblies of an avionics system

that is installed in an aircraft, with the exception of cables, mounts, and fuse boxes or circuit breakers. Figure 5-35 is an example of how WRAs may be installed in the aircraft.

Shop replaceable assembly (SRA) is the term that includes all the assemblies within a WRA. SRAs also may have replaceable subassemblies. SRAs also may be referred to by other terms. The following are a few you should be aware of:

- PCB's- Printed Circuit boards
- EMs- Electronic Modules
- CCAs- Circuit Card Assemblies

In figure 5-36 are a few examples of the types of SRAs you may see.

## REPAIR PROCEDURES

Once the organizational level (O-level) activity or squadron has determined the defective unit in the aircraft, the defective unit is sent to next higher maintenance level for repair. Normally this will be the intermediate level (I-level) activity or aircraft intermediate maintenance department (AIMD).

The maintenance level for repair of a particular WRA or SRA can be determined by the source, maintenance and recoverability (S, M, & R) code. However, repair capabilities of an intermediate maintenance activity (IMA) is dependent on overcoming the following obstacles:

- Lack of skills
- Lack of equipment or tools
- Lack of facilities
- Lack of personnel
- Lack of technical data
- Lack of parts

The depth of repair for IMA also is dependent on the IMA's ability to perform 2M (miniature/microminiature) repair. 2M repair involves the removal and replacement of discrete components (transistors, resistors, capacitors, etc.) along with intricate soldering repair. 2M repair should only be done by certified 2M technicians. You can find detailed information on the 2M program in the *Naval Aviation Maintenance Program (NAMP)*, OPNAVINST 4790.2 (series), Vol. 5, chapter 23.

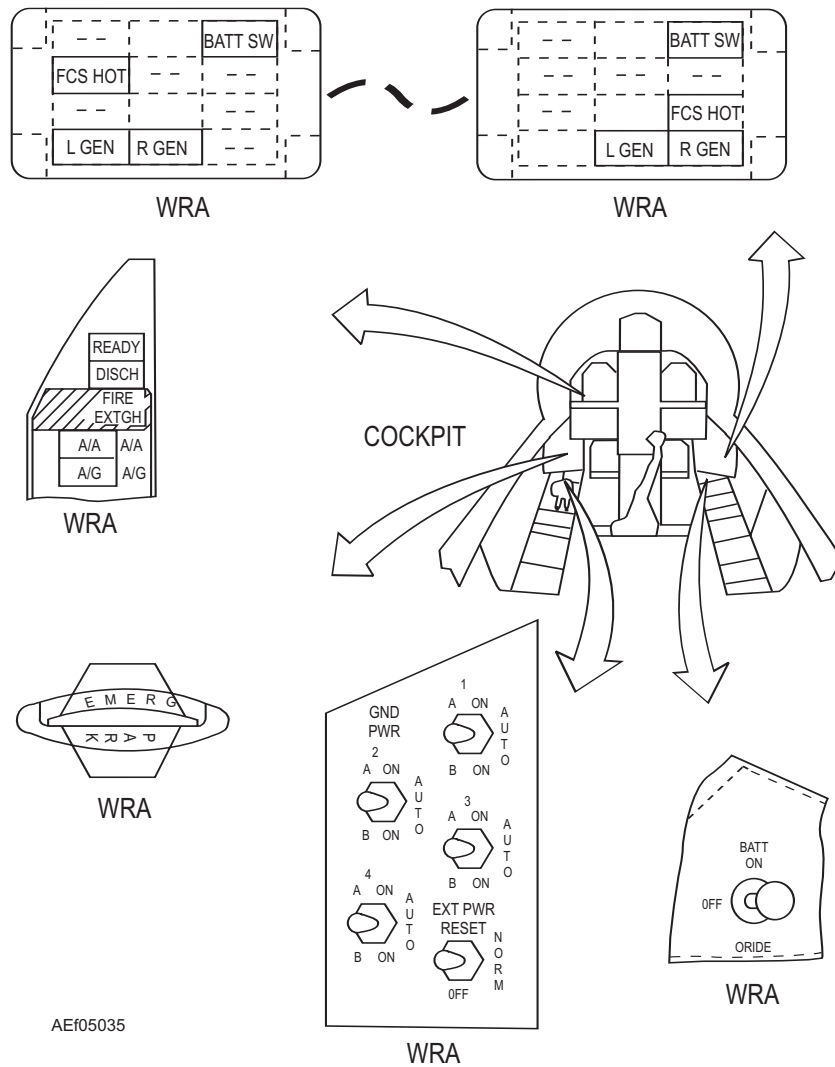
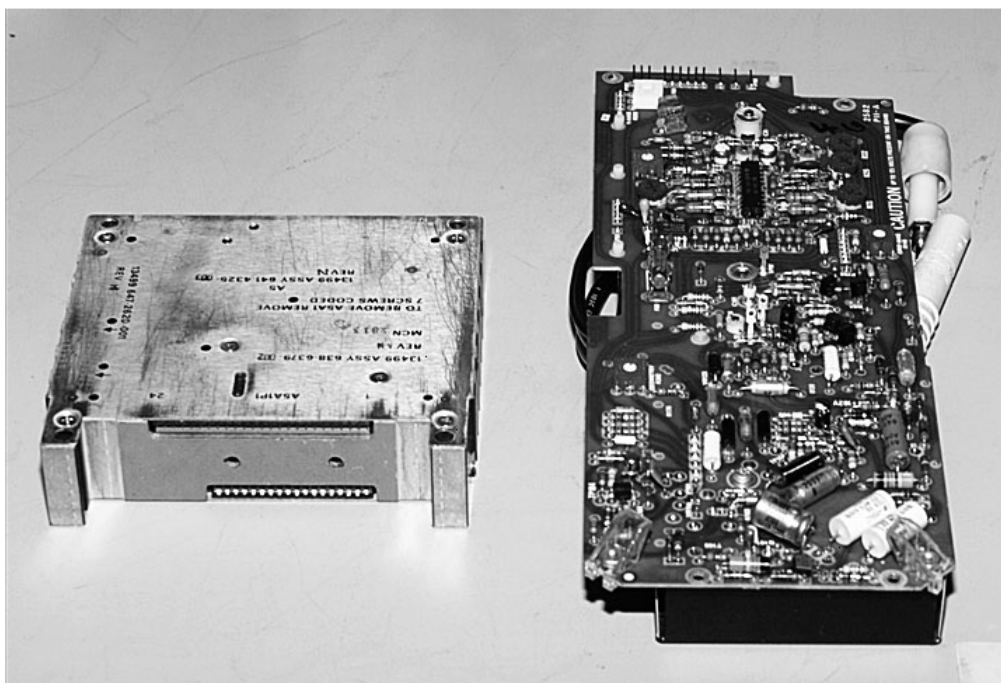

Figure 5-35.—Examples of WRA installation.



AEf05036

Figure 5-36. —Examples of SRAs.

- Q5-36. What is the meaning of the term WRA?
- Q5-37. Who is authorized to make soldering repairs?
- Q5-38. What should you use to determine the maintenance level for repair of a defective assembly?

### ELECTROSTATIC DISCHARGE (ESD)

**LEARNING OBJECTIVES:** Recognize the cause and effect of static electricity. Recognize the hazards of ESD to components. Recognize control and elimination procedures of ESD.

The sensitivity of electronic devices and components to electrostatic discharge (ESD) has recently become clear through use, testing, and failure analysis. The construction and design features of current microtechnology have resulted in devices being destroyed or damaged by ESD voltages as low as 20 volts through improper handling. The trend is toward greater complexity, increased packaging density, and thinner dielectrics between active elements, which will result in devices even more sensitive to ESD.

Your knowledge of ESD cause and effects, hazards, control, elimination and repair of damage will decrease maintenance costs and time.

### STATIC ELECTRICITY

Static electricity is electrical energy at rest. Some substances readily give up electrons while others accumulate excessive electrons. When two substances are rubbed together, separated, or flow relative to one another (such as a gas or liquid over a solid), one substance becomes negatively charged and the other positively charged. An electrostatic field or lines of force radiate between a charged object to an object at a different electrostatic potential (such as more or less electrons) or ground. Objects entering this field will receive a charge by induction.

The capacitance of the charged object relative to another object or ground also has an effect on the field. If the capacitance is reduced, there is an inverse linear increase in voltage, since the charge must be conserved. As the capacitance decreases, the voltage increases until a discharge occurs via an arc.

### Causes Of Static Electricity

Generation of static electricity on an object by rubbing is known as the *triboelectric effect*. Table 5-5 lists substances in the triboelectric series.

Table 5-5.—Triboelectric Series

<b>POSITIVE (+)</b>
ACETATE
GLASS
HUMAN HAIR
NYLON
WOOL
FUR
ALUMINUM
POLYESTER
PAPER
COTTON
WOOD
STEEL
ACETATE FIBER
NICKEL, COPPER, SILVER
BRASS, STAINLESS STEEL
RUBBER
ACRYLIC
POLYSTYRENE FOAM
POLYURETHANE FOAM
SARAN
POLYETHYLENE
POLYPROPYLENE
PVC (VINYL)
KEL F
TEFLON
<b>NEGATIVE (-)</b>
NOTE: THE TRIBOELECTRIC SERIES IS ARRANGED IN SUCH AN ORDER THAT WHEN ANY TWO SUBSTANCES IN THE LIST CONTACT ONE ANOTHER AND ARE SEPARATED, THE SUBSTANCE HIGHER ON THE LIST ASSUMES A POSITIVE CHARGE.

The size of an electrostatic charge on two different materials is proportional to the separation of the two materials.

Electrostatic voltage levels generated by nonconductors can be extremely high. However, air slowly dissipates the charge to a nearby conductor or ground. The more moisture in the air, the faster a charge dissipates. Table 5-6 shows typical measured charges generated by personnel in a manufacturing facility. You can see that the generated voltage decreases with an increase in humidity levels of the surrounding air.

### Component Susceptibility and Failure

Various devices and components are susceptible to damage by electrostatic voltage levels commonly generated in production, test, operation, and by maintenance personnel. These devices and components include the following:

- All microelectronic and most semiconductor devices, except for various power diodes and transistors
- Thick and thin film resistors, chips and hybrid devices, and crystals

All subassemblies, assemblies, and equipment containing these components/devices without adequate protective circuitry are ESD-sensitive (ESDS).

You can protect ESDS items by implementing simple, low-cost ESD controls. Lack of implementation has resulted in high repair costs,

excessive equipment downtime, and reduced equipment effectiveness.

ESD overstress can produce a dielectric breakdown of a self-healing nature when the current is unlimited. When this occurs, the device may retest as good. However, it contains a hole in the gate oxide. With use, metal will eventually migrate through the puncture, resulting in a shorting of this oxide layer.

Another structure mechanism involves highly limited current dielectric breakdown from which no apparent damage is done. However, this reduces the voltage at which subsequent breakdown occurs to as low as one-third of the original breakdown value. ESD damage can result in a lowered damage threshold at which a subsequent lower voltage ESD will cause further degradation or a functional failure.

### ESD CONTROL AND ELIMINATION

The heart of an ESD control program is the ESD-protected work area and ESD-grounded work station. When you handle an ESD-sensitive (ESDS) device outside of its ESD protective packaging, you need to provide a means of reducing generated electrostatic voltages below the levels at which the item is sensitive. The greater the margin between the level at which the generated voltages are limited and the ESDS item sensitivity level, the greater the probability of protecting that item.

**Table 5-6.—Typical Measured Electrostatic Voltages**

MEANS OF STATIC GENERATION	VOLTAGE LEVELS @ RELATIVE HUMIDITY	
	LOW-10-20 %	HIGH-65-90%
WALKING ACROSS CARPET	35,000	1,500
WALKING OVER VINYL FLOOR	12,000	250
WORKER AT BENCH	6,000	100
VINYL ENVELOPES FOR WORK INSTRUCTIONS	7,000	600
COMMON POLY BAG PICKED UP FROM BENCH	20,000	1,200
WORK CHAIR PADDED WITH URETHANE FOAM	18,000	1,500

**PRIME GENERATORS**

Look at table 5-7. It lists ESD prime generators. All common plastics and other prime generators of static electricity should be prohibited in the ESD-protected work area. Carpeting also should be prohibited. If you must use carpet, it should be of a permanently anti-static type. Perform weekly static voltage monitoring where carpeting is in use.

**PERSONAL APPAREL AND GROUNDING**

An essential part of the ESD program is grounding personnel and their apparel when they handle ESDS material.

**Smocks**

Personnel handling ESDS items should wear long-sleeve ESD-protective smocks, short-sleeve shirts or blouses, and ESD-protective gauntlets banded to the bare wrist and extending toward the elbow. If these items are not available, use other anti-static material (such as cotton) that will cover sections of the body that could contact an ESDS item during handling.

**Personnel Ground Straps**

Personnel ground straps should have a minimum resistance of 250,000 ohms. The wrist, leg, or ankle bracelet end of the ground strap should have some

**Table 5-7.—Typical Charge Generators**

WORK SURFACES	<ul style="list-style-type: none"> <li>• FORMICA (WAXED OR HIGHLY RESISTIVE)</li> <li>• FINISHED WOOD</li> <li>• SYNTHETIC MATS</li> </ul>
FLOORS	<ul style="list-style-type: none"> <li>• WAX FINISHED</li> <li>• VINYL</li> </ul>
CLOTHES	<ul style="list-style-type: none"> <li>• COMMON CLEAN ROOM SMOCKS</li> <li>• PERSONNEL GARMENTS (ALL TEXTILES EXCEPT VIRGIN COTTON)</li> <li>• NON CONDUCTIVE SHOES</li> </ul>
CHAIRS	<ul style="list-style-type: none"> <li>• FINISHED WOOD</li> <li>• VINYL</li> <li>• FIBERGLASS</li> </ul>
PACKAGING AND HANDLING	<ul style="list-style-type: none"> <li>• COMMON POLYETHYLENE—BAGS, WRAPS, ENVELOPES</li> <li>• COMMON BUBBLE PACK, FOAM</li> <li>• COMMON PLASTIC TRAYS, PLASTIC TOTE</li> <li>• BOXES, VIALS</li> </ul>
ASSEMBLY, CLEANING, TEST AND REPAIR AREAS	<ul style="list-style-type: none"> <li>• SPRAY CLEANERS</li> <li>• COMMON SOLDER SUCKERS</li> <li>• COMMON SOLDER IRONS</li> <li>• SOLVENT BRUSHING (SYNTHETIC BRISTLES)</li> <li>• CLEANING, DRYING</li> <li>• TEMPERATURE CHAMBERS</li> </ul>

metal contact with the skin. Bracelets made completely of carbon-impregnated plastic may burnish around the area in contact with the skin, resulting in too high an impedance to ground.

To ensure personnel grounding straps are safe, periodic maintenance and preoperational checks of ESD work areas should be performed per the following publications:

- NAVAIR 17-600-141-6-1
- NAVAIR 17-600-141-6-2
- NAVAIR 17-600-193-6-2

### **ESD-protective Materials**

There are two basic types of ESD-protective materials—conductive and anti-static. Conductive materials protect ESD devices from static discharges and electromagnetic fields. Anti-static material is a nonstatic-generating material. Other than not generating static, anti-static material offers no other protection to an ESD device.

**CONDUCTIVE ESD-PROTECTIVE MATERIALS.**—Conductive ESD-protective materials consist of metal, metal-coated, and metal-impregnated materials (such as carbon particle impregnated, conductive mesh or wire encased in plastic). The most common conductive materials used for ESD protection are steel, aluminum, and carbon-impregnated polyethylene and nylon. The latter two are opaque, black, flexible, heat sealable, electrically conductive plastics. These plastics are composed of carbon particles, impregnated in the plastic, which provides volume conductivity throughout the material.

**ANTI-STATIC ESD PROTECTIVE MATERIALS.**—Anti-static materials are normally plastic materials (such as polyethylene, polyolefin, polyurethane, nylon) that are impregnated with an anti-static substance. This anti-static substance migrates to the surface and combines with the humidity in the air to form a conductive sweat layer on the surface. This layer is invisible and, although highly resistive, is conductive enough to prevent the buildup of electrostatic charges by triboelectric (or rubbing) methods in normal handling. Simply stated, the primary asset of an anti-static material is that it will not generate a charge on its surface. However, this material won't protect an enclosed ESD device if it comes into contact with a charged surface.

Anti-static material is tinted pink, a symbol of its being anti-static. Anti-static materials are used for inner-wrap packaging. However, anti-static trays, vials, carriers, boxes, etc., are not used unless components and/or assemblies are wrapped in conductive packaging.

**HYBRID ESD-PROTECTIVE BAGS.**—Hybrid ESD-protective bags are a laminate of different ESD-protective materials. They are made from conductive and anti-static materials. The hybrid ESD-protective bag provides the advantages of both types of materials in a single bag.

### **ESDS Device Handling and Packaging**

The following are general guidelines that you should follow when handling ESDS devices:

- Ground all containers, tools, test equipment, and fixtures used in ESD-protective areas before and/or during use, either directly or by contact with a grounded surface.
- Avoid physical activities around ESDS items that are friction-producing; for example, removing or putting on smocks, wiping feet, sliding objects over surfaces, etc.
- Wear cotton smocks and/or other anti-static treated clothing.
- Avoid the use or presence of plastics, synthetic textiles, rubber, finished wood, vinyls, and other static-generating materials, especially when handling ESDS out of their ESD-protective packaging.
- Place the ESD protective material containing the ESD item on a grounded work bench surface to remove any charge before opening the packaging material.
- Attach personnel grounding strap before removing ESDS items from their protective packaging.
- Remove ESDS items from ESD-protective packaging only after grounding, and place on the ESD-grounded work bench surface.
- Make periodic electrostatic measurements at all ESD-protected areas. This assures the ESD-protective properties of the work station and all equipment contained there have not degraded.

- Perform periodic continuity checks of personnel ground straps (between skin contact and ground connection), ESD-grounded work station surfaces, conductive floor mats, and other connections to ground. Perform this check with a megohmmeter to make sure grounding resistivity requirements are met.

Before an ESDS item leaves an ESD-protected area, ensure shorting bars, clips, or noncorrective conductive materials are inserted correctly in or on all terminals or connectors. A list of approved ESD

anti-static protective materials for packaging can be found in OPNAVINST 4790.2 series, Vol. 5, chapter 22.

*Q5-39. ESD-sensitive devices can be damaged by electrostatic voltages as low as \_\_\_\_\_?*

*Q5-40. When handling ESDS devices, personnel and their apparel should be connected to \_\_\_\_\_?*

*Q5-41. What is the minimum resistance for personnel ground straps?*

*Q5-42. What color is material that is antistatic?*



## CHAPTER 5

# ANSWERS TO REVIEW QUESTIONS

- A5-1. *All hands*
- A5-2. *De-energize the circuit*
- A5-3. *Certified CPR training*
- A5-4. *MIM*
- A5-5. *Someone qualified to render first aid*
- A5-6. *Current*
- A5-7. *Beryllium-copper tools*
- A5-8. *CO<sub>2</sub>*
- A5-9. *30*
- A5-10. *Scheduled and unscheduled*
- A5-11. *Visual checks, cleaning, lubricating, and periodic checks*
- A5-12. *NAVAIR 16-1-540*
- A5-13. *Scheduled and unscheduled maintenance*
- A5-14. *Maintenance performed to reduce the likelihood of future troubles or malfunctions*
- A5-15. *Determine if the equipment in question is actually faulty*
- A5-16. *To check for opens or to see if a circuit is complete or continuous*
- A5-17. *The major method for testing these components is to take resistance measurements and compare them with schematics, MIMs, or identical operational equipment*
- A5-18. *Signal tracing*
- A5-19. *Distorted waveshape of the observed signal*
- A5-20. *Ensure no voltages are present*
- A5-21. *Operational check*
- A5-22. *Ohmic value, wattage rating, tolerance, physical dimensions, and type of construction*
- A5-23. *1<sup>st</sup> band: Brown; 2<sup>nd</sup> band: Black; 3<sup>rd</sup> band: Brown; 4<sup>th</sup> band: Silver (see fig. 5-4)*
- A5-24. *Aircraft's MIM (maintenance instructions manual)*
- A5-25. *Mil-W-22759*
- A5-26. *15 inches maximum*
- A5-27. *Wire or cable that completes the circuit to ground*
- A5-28. *1 inch*
- A5-29. *Prevent damage to cable insulation*
- A5-30. *Insulates and relieves strain on a wire*
- A5-31. *Aircraft Structural Hardware for Aircraft Repair; NAVAIR 01-1A-8*
- A5-32. *Corrosion, strength, size, length, magnetic properties, special features, and lubrication or coating of the substitution part*
- A5-33. *To separate the wire bundle from the plumbing line*
- A5-34. *TB*
- A5-35. *To prevent accidental loosening of aircraft equipment and connectors due to vibration*
- A5-36. *Weapons Replaceable Assembly*
- A5-37. *Certified 2M technicians*
- A5-38. *S, M, & R code*
- A5-39. *20 volts*
- A5-40. *Ground*
- A5-41. *250,000 ohms*
- A5-42. *Pink*



## CHAPTER 6

# COMMON TEST EQUIPMENT

The list of weapons systems in modern day aircraft is very long, as is the list of test equipment required in maintaining these systems. It's very difficult for an individual to know all the various types of electronic systems in use in today's naval aircraft along with the equipment used to test these complex systems. However, with a general background in electronic principles and circuit theory, and a little study, Aviation Electricians and Aviation Electronics Technicians at the intermediate and organizational maintenance levels can rapidly become familiar with any specific system or test equipment they encounter. In this chapter, you will learn about the care and handling of test equipment, some common types of general-purpose electronic test equipment (GPETE), and automatic test equipment (ATE).

### CARE AND HANDLING OF TEST EQUIPMENT

**LEARNING OBJECTIVE:** Identify the proper care and handling of avionics test equipment to include calibration, repair, and handling precautions.

Aviation electronic and electrical maintenance shops require many pieces of test equipment to maintain electronic and electrical systems. There are few spare pieces of test equipment. So when test equipment becomes inoperative, shop maintenance suffers.

### CALIBRATION

Most test equipment requires calibration. To calibrate test equipment, a calibration technician compares the equipment to calibration standards of higher accuracy and adjusts or repairs the test equipment to ensure that the equipment is operating within established tolerances. Calibration standards in turn are calibrated by standards of even higher accuracy. These standards are traceable back to the National Institute of Standards and Technology or the U.S. Naval Observatory.

All test equipment and calibration standards used for quantitative measurements must be calibrated. In the Navy, the equipment to be calibrated is forwarded to

the lowest level facility that is capable of doing the calibration. This means that maintenance activities forward all their test equipment through work center 670 at the intermediate maintenance activity (IMA). In turn, work center 670 calibrates or repairs the equipment within its capability. If calibration or repair is beyond its capability, it forwards the equipment on to a depot-level maintenance activity. Calibration intervals and individual calibration procedures for test equipment can be found in *Metrology Requirements List (METRL)*, NAVAIR 17-35MTL-1, which is retained by work center 670.

### REPAIR

The end user of test equipment normally makes only minor repairs to equipment, which do not effect the calibration. Repairs are usually limited to the replacement of test leads, power cables, and fuses, which will not break "calibration void" seals. See figure 6-1. Before you make any repair, consult with work center 670. Personnel assigned to 670 repair test equipment on a much wider scale. Repair can vary from the replacement of circuit components to replacement of modules, depending on the depth of the repair.

### HANDLING PRECAUTIONS

Some test equipment requires special handling; however, several precautions apply to test equipment in general. Rough handling, moisture, and dust all affect the service life of test equipment. For example, bumping or dropping a test instrument can destroy the calibration of an analog meter or short circuit the elements of an electronic tube within the equipment. Creasing or denting coaxial cables and connectors can

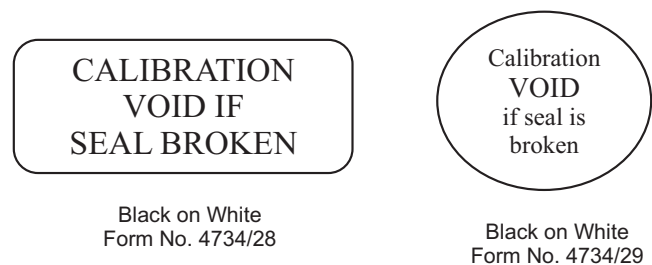

AEI06001

Figure 6-1.—Calibration void seals.

alter their attenuation value. This attenuation difference can be either an increase or decrease in the amplitude of a signal during its transmission from one point to another by affecting the electrical current, voltage, or power quantities of the signal. Excessive dust and grime inside test equipment affect its accuracy along with its cooling capabilities. Be sure all assembly screws that hold the case of the test equipment in place are tight and secure. As an added precaution, place a dust cover on test equipment when it is not in use. Each technician should always abide by the following general rules when handling test equipment:

- Use test equipment properly for its designed purpose.
- Select the proper range for the measured quantity.
- Protect the equipment from physical harm that may result from dropping, falling, or other misuse.
- Store test equipment in a clean, dry place with dust covers attached. (This reduces the chances of corrosion and water intrusion).
- Use the test equipment instruction manual.

The instruction manual that comes with the test equipment contains procedures for the proper handling and stowing of the equipment and accessories. Read this manual carefully and follow the equipment instructions. Improper storage of equipment and accessories can cause unreliable test equipment indications and intermittent shorts in cables and leads.

- Q6-1. The process of comparing test equipment to a standard of higher accuracy is known by what term?*
- Q6-2. Test equipment requiring calibration or repair should be forwarded to what IMA work center?*
- Q6-3. What are the general rules for the handling of test equipment?*

## MEASURING EQUIPMENT

**LEARNING OBJECTIVE:** Identify the types and uses of measuring equipment to include digital multimeters, AC voltmeters and thermocouple ammeters, megohmmeters, electronic counters, power meters, oscilloscopes, and spectrum analyzers.

The term measuring equipment includes the class of test equipment that measures basic parameters of electronic equipment that you will use while maintaining a wide variety of weapons systems. The basic parameters that will be measured are voltage (V), current (A), resistance ( $\Omega$ ), power (W), and frequency (Hz). Measuring equipment includes digital multimeters, ac voltmeters, thermocouple ammeters, megohmmeters, electronic counters, power meters, oscilloscopes, and spectrum analyzers.

## DIGITAL MULTIMETERS

Today's naval aircraft have sophisticated on-board computers and communication systems, electronic motors controlled by electronic drives, and electronic circuits in everything from coffee makers to spacecraft. Servicing, repairing, and installing this equipment requires diagnostic tools that give accurate information, such as a digital multimeter (DMM). DMMs are the most common voltmeters used in the Navy today. The DMM displays readings numerically, reducing human error and increasing the speed at which the measurement is read. Automatic range and polarity changing features also reduce human error. Many DMMs have outputs to computers, printers, and magnetic tape equipment.

Many analog multimeters still remain in the fleet today. An analog meter displays readings by the use of a pointer and scale, increasing human error and decreasing the speed at which the measurement can be read. Automatic range and polarity changing features are not available on analog type meters. Therefore, consult the manufacturers publication that comes supplied with the meter for proper operating instructions.

## Measuring Voltage

One of the most basic tasks of a DMM is measuring voltage. A typical direct current voltage (dc) source is a battery like the one used in your car. A generator usually creates alternating current (ac) voltage. The wall outlets in your home are common sources of ac voltage. Some devices convert ac to dc. For example, electronic equipment such as TVs, stereos, VCRs and computers that you plug into an ac wall outlet use devices called rectifiers to convert the ac voltage to a dc voltage. This dc voltage is what powers the electronic circuits in these devices. Checking for proper supply voltage is the first thing that you should check when troubleshooting a circuit. If there is no voltage present,

Table 6-1.—Steps for Making Voltage Measurements

STEP	ACTION
1	Select Volts AC (V~) or Volts DC (V ---), as desired.
2	Plug the black test lead into the COM input jack. Plug the red test lead into the V input jack.
3	Touch the probe tips to the circuit across a load or power source (in parallel with the circuit).
4	View the reading, being sure to note the unit of measurement.

or if it is too high or too low, you should correct the voltage problem first. The waveforms associated with ac voltages are either sinusoidal (sine waves), or nonsinusoidal (sawtooth, square, ripple, and so forth). Quality DMMs display the root-mean-square (rms) value of these voltage waveforms. The rms value is the effective or equivalent dc value of the ac voltage. Most meters, called *average responding*, give accurate rms readings if the ac voltage signal is a pure sine wave. Average-responding meters are not capable of measuring non-sinusoidal signals accurately. Nonsinusoidal signals are accurately measured by using DMMs designated as *true-rms*. A DMM's ability to measure ac voltage can be limited by the frequency of the signal being measured. Most DMMs can accurately measure ac voltages with frequencies from 50 Hz to 500 Hz, but when high frequency signals are measured, it becomes more complicated. The sensitivity of the meter determines the lowest voltage that a meter can measure accurately and the shunt capacitance of the meter input determines the high frequency response of the meter. You should know the frequency response of a DMM when measuring high frequency signals because the accuracy of the meter will vary greatly from one manufacturer to another.

Table 6-1 lists the steps you should take when making voltage measurements. Refer to figure 6-2 when reviewing table 6-1.

For dc readings you must determine the correct polarity of the circuit. Touch the red test probe to the positive side of the circuit and the black probe to the negative side or to the circuit ground. If you reverse the connections, a DMM with auto-polarity will merely display a minus sign indicating negative polarity.

An accessory used with the DMMs is the high voltage probe. It is used when potentials in a circuit to be measured exceed the input rating of the DMM. Generally they are used when voltages exceed 600 volts. The use of these probes is mandatory when maintaining cathode ray tube (CRT) deflection circuits, high-voltage rectifier circuits, televisions, radio, and

radar equipment, where voltages can reach up to 40 kilovolts (kV).

### CAUTION

High-voltage probes are not intended for electrical utility applications in which high voltage also is accompanied by high energy. Rather, they are intended for use **only** in low-energy applications.



Figure 6-2.—Fluke model 27 multimeter.

Table 6-2.—Steps for Making Resistance Measurements

STEP	ACTION
1	Disconnect power to the circuit.
2	Select resistance ( $\Omega$ ).
3	Plug the black test lead into the COM input jack. Plug the red test lead into the $\Omega$ input jack.
4	Connect test leads across the component or portion of the circuit for which resistance is to be determined.
5	View the reading, being sure to note the unit of measurement.

### Measuring Resistance

Resistance is measured in ohms ( $\Omega$ ). Resistance values can vary greatly, from a few milliohms ( $m\Omega$ ) for contact resistance to billions of ohms ( $G\Omega$ ) for insulators. Most DMMs measure down to  $0.1\Omega$ , and some measure as high as 300 megohms ( $M\Omega$ ) (300,000,000 ohms). When “OL” appears on the Fluke meter display, it means the resistance is greater than the meter can measure.

#### NOTE

Resistance measurements **must be made with the circuit power off**—otherwise, the meter or circuit could be damaged.

Some DMMs provide protection in the ohms mode in case of accidental contact with voltages. The level of protection varies greatly among different DMM models. For accurate low-resistance measurements, resistance in the test leads must be subtracted from the total resistance measured. Typical test lead resistance is between  $0.2\ \Omega$  and  $0.5\ \Omega$ . If the resistance in the test

leads is greater than  $1\ \Omega$ , the test leads should be replaced. If the DMM supplies less than 0.6 Vdc test voltage for measuring resistance, it will be able to measure the values of resistors that are isolated in a circuit by diodes or semiconductor junctions. This often allows you to test resistors on a circuit board without unsoldering them. Table 6-2 lists the steps you should take when making resistance measurements. Refer to figure 6-2 when reviewing table 6-2.

### Measuring Current

Current measurements are different from other measurements made with a DMM. Current measurements are taken directly by placing the meter in series with the circuit being measured, thus allowing all the circuit current to flow through the meter circuitry. Table 6-3 lists the steps you should take when making current measurements. Refer to figure 6-2 when reviewing table 6-3.

An indirect method of measuring current can be used that does not require the circuit to be opened and the meter placed in series. This indirect method is accomplished by the use of a current probe.

Table 6-3.—Steps for Making Current Measurements

STEP	ACTION
1	Disconnect power to the circuit.
2	Cut, disconnect, or desolder the circuit, creating a place where the meter leads can be connected.
3	Select Amps AC ( $A\sim$ ) or Amps DC ( $A\text{---}$ ) as desired.
4	Plug the black test lead into the COM input jack. Plug the red test lead into the 10 Amp (10 A) or 300 milliamp (300 mA) input jack, depending on the expected value of the reading.
5	Reconnect power to the circuit.
6	View the reading, being sure to note the unit of measurement.

**NOTE:** If the test leads are reversed, a minus sign (–) will appear in the display.

## Continuity

Continuity is a quick go/no-go resistance test that distinguishes between an open and a closed circuit. A DMM with a continuity beeper allows you to complete many continuity tests easily and quickly. The meter beeps when it detects a closed circuit, so you don't have to look at the meter as you test. The level of resistance required to trigger the beeper varies from model to model of DMM.

## Diode Test

A diode is like an electronic switch. It can be turned on if the voltage is over a certain level, generally about 0.6 Vdc for a silicon diode, and it allows current to flow in one direction. Most DMMs have a diode test mode. This mode measures and displays the actual voltage drop across a junction. A silicon junction should have a voltage drop less than 0.7 volts when applied in the forward direction and an open circuit when applied in the reverse direction.

## Measuring Dc Power

The formula for calculating dc power is straightforward—the unit of power (P), the watt, is the product of the potential in volts (E) and the current (I) in amperes or  $P = IE$ . To determine dc power, you use Ohm's law, make the basic circuit measurements, and compute dc power by using the power formula.

## MODEL 27 AND 8840A DIGITAL MULTIMETERS

The model 27 and 8840A multimeters, shown in figures 6-2 and 6-3, are examples of two digital multimeters currently used in the fleet. Table 6-4 shows a comparison of the features of the Model 27 and 8840A DMMs. The chart also gives general operating parameters of the two models.

- Q6-4. *True-rms meters are used to measure what types of signals?*
- Q6-5. *What factor must you take into account when measuring high frequency ac signals?*
- Q6-6. *When measuring voltage with a DMM, how should the test leads be placed with regard to the circuit?*
- Q6-7. *A test lead should be replaced when the resistance measured is greater than what value?*
- Q6-8. *When taking resistance readings of a circuit the technician should ensure the circuit is in what condition prior to taking any measurements?*
- Q6-9. *When current measurements are made with a multimeter, the test leads should be placed in what configuration in regards to the circuit being tested?*



Figure 6-3.—Fluke model 8840A multimeter.

**Table 6-4.—Fluke 27 and Fluke 8840A Comparison**

<b>DIGITAL MULTIMETER FEATURES</b>	<b>FLUKE 27</b>	<b>FLUKE 8840A</b>
DC Voltage Ranges and Resolution	320.0 mV, 3.200 V, 32.00 V, 320.0V, and 1000 V	199.999 mV, 1.99999 V, 19.9999 V, 199.999 V, and 1000.00 V
AC Voltage Ranges and Resolution	320.0 mV, 3.200 V, 32.00 V, and 320.0V	199.999 mV, 1.99999V, 19.9999V, 199.999 V, and 700.00 V
ADC Ranges and Resolution	320 0 $\mu$ A, 3200 $\mu$ A, 32.00 mA, 320.0 mA, and 10.0 A	1999.99 mA
AAC Ranges and Resolution	320 0 $\mu$ A, 3200 $\mu$ A, 32.00 mA, 320.0 mA, and 10.00 A	1999.99 mA
Resistance Ranges and Resolution	320 $\Omega$ , 3.200 k $\Omega$ , 32.00 k $\Omega$ , 320.0 k $\Omega$ , 3.200 M $\Omega$ , and 32.00 M $\Omega$	199.999 $\Omega$ , 1.99999 k $\Omega$ , 19.9999 k $\Omega$ , 199.999k $\Omega$ , 1999.99 k $\Omega$ , and 19.9999 M $\Omega$
Power Requirements	Alkaline battery	Line power 90 to 132 Vac, or 198 to 250 Vac
Application	General purpose, hand held	General purpose bench or rack system applications
Special Features	<p>Analog bar graph for use when making nulling adjustments</p> <p>Auto and manual ranging</p> <p>Shock resistant, and waterproof to a depth of 3ft</p> <p>Audible beep continuity checker/Diode test</p> <p>Automatic measurement hold feature</p>	<p>Large display for viewing ease</p> <p>Built-in diagnostic self-test functions</p> <p>Auto and manual ranging</p> <p>Computer interface capability allows complete control and data output capability</p> <p>Offset function that allows storage of a reference value</p> <p>2-wire and 4-wire resistance capabilities for accurate readings</p>

*Q6-10. When a multimeter makes a beeping sound when the continuity across the contacts of a switch is checked, the switch is in what position?*

**AC VOLTMETERS AND THERMOCOUPLE AMMETERS TO MEASURE AC POWER**

It is often necessary to check the power consumption and the input and output signal power levels of electronic equipment. To make ac power measurements, you must consider the phase angle of the voltage and current. Measurements are further complicated by the frequency limitations of power

meters. If there is no phase difference, computing ac power is accomplished in the same manner as dc power—by determining the average value of the product of voltage and current.

Many ac voltmeters have scales calibrated in decibels (dB) or decibels referenced to 1 milliwatt (dBm). Such meters are used to make measurements where direct indication in decibels is desired. Remember that these are voltmeters and that power measurements are not meaningful unless the circuit impedance is known.

At radio frequencies (RF) below the ultrahigh frequency (UHF) range, voltage, current, and



impedance measurements usually can be used to determine power. One common method used to determine the output power of RF oscillators and radio transmitters consists of connecting a known resistance (R) to the equipment output terminals. After measuring the current flow through the resistance, you then calculate the power as the product of  $I^2R$ . Since the power is proportional to the current squared, the meter scale can indicate power units directly. A thermocouple ammeter is used to measure RF current. The resistor used to replace the normal load is of special design. It has to have low reactance (to limit the effect of conductance and inductance on R) and the ability to dissipate the required amount of power. Resistors used for this purpose are called dummy loads or dummy antennas.

## MEGOHMMETER (MEGGER)

The megohmmeter, commonly called the *megger*, is an instrument that applies the high voltage that is needed to measure the current leakage of a component such as a capacitor or an insulated electrical cable. This lets you check for leakage under much higher voltages than an ohmmeter supplies. The common megger consists of a hand-driven voltage generator and an indicating meter. Other meggers have similar circuitry with a battery-driven voltage generator.

### Megger Ratings

There are various resistance ratings of meggers with full-scale values that measure resistance as low as 5 megohms to as high as 10,000 megohms. Megger voltage ratings vary with the model. Common megger insulation testing voltages are 100 V, 250 V, 500 V, and 1,000 V. Voltage rating refers to the output voltage of the megger. The voltage rating is important. If you apply too high a voltage, it will cause even a good component to break down. For example, you should not use a 500-V megger to test a capacitor rated at 100 V.

### Megger Use

To test for current leakage, you apply the voltage produced by the megger between the conductor and the outside of the insulation. You read the value of the resistance you are measuring on the indicating meter. You can use a megger to test the insulation resistance of a conductor that may be shorting or breaking down under high voltage. In some situations, you can use a megger to prevent an unnecessary breakdown by maintaining records of insulation resistance of power

and high-voltage cables, motor and generator windings, and transmission lines. These records would reflect fluctuations in resistance and help determine when to replace the cable, windings, or transmission line to prevent a breakdown.

Meggers are used to test capacitors whose peak voltages are not below the output of the megger. They also are used to test for high-resistance grounds or leakage on devices such as antennas and insulators.

### Precautions when Using a Megger

Use the following precautions when taking measurements with a megger:

- Use a megger for the measurements it is rated for only.
- When you are making a megger test, do not energize the equipment. Disconnect the equipment entirely from the system before testing.
- Observe all safety rules in preparing equipment for test and in testing, especially when testing an installed high-voltage apparatus.
- Use well-insulated test leads, especially when using high-range meggers. Check the leads after connecting them to the megger and before connecting them to the component under test. Operate the megger and make sure there is no leak between the leads. The reading should be infinity. Check the leads by touching the test ends of the leads together while turning the crank slowly. The reading should be about zero. If the indication reads differently, you may have a faulty lead or a loose connection.
- When using a high-range megger, take proper precautions against electric shock. There is enough capacitance in most electrical equipment to store up energy from the megger generator to give a very disagreeable and even dangerous electric shock. Because there is a high protective resistance in the megger, its open circuit voltage is not as dangerous as it would otherwise be, but still be careful.
- Discharge equipment having considerable capacitance before and after megger tests. This should help you avoid receiving a dangerous shock. You can do this by grounding or short-circuiting the terminals of the equipment under test.

## MJ10 megger and BM12 Megger

The MJ10 and BM12 meggers, shown in figure 6-4, are two common meggers used throughout the fleet. Both of these meggers are convenient and easy to use when they are used to test, service, or maintain electrical equipment. Table 6-5 shows a comparison of the features of the MJ10 and BM12 meggers and their general operating parameters.

- Q6-11. *What is the purpose of a megger?*
- Q6-12. *Identify at least two components that can be tested with a megger.*
- Q6-13. *A megger consists of what two major elements?*
- Q6-14. *With the test leads connected to the megger and shorted together, what should be the resistance of the leads?*
- Q6-15. *What action must be performed following completion of a megger test on equipment having considerable capacitance to avoid dangerous shock?*
- Q6-16. *What is the major difference between the MJ10 megger and the BM12 megger?*

## ELECTRONIC COUNTERS

Frequency measurements are an essential part of preventive and corrective maintenance in communication and electronic work centers. Radio transmitters must be accurately tuned to the assigned frequencies to provide reliable communications and to avoid interfering with radio circuits operating on other frequencies. Radar sets must be properly tuned to obtain satisfactory performance.

Electronic counters, which combine accuracy and speed, are now the most widely used method of measuring frequency and other timed events. A frequency counter is referred to as an electronic counter because it actually counts electrical events. Electronic counters can accurately measure frequencies to 46 GHz. In addition to direct frequency measurements, electronic counters can do the following:

- Measure the period of a signal, which is the inverse of frequency.
- Calculate the ratio that compares one frequency against another.
- Measure the time interval between two events or the time between two functions of an event. Time interval capability is employed in measuring the interval between two pulses or between two sets of pulses.



Figure 6-4.—MJ10 and BM12 meggers.

**Table 6-5.—MJ10 and BM12 Comparison**

<b>MEGOHMMETER</b>	<b>MJ10</b>	<b>BM12</b>
DC Test Voltage Ranges	100 Vdc, 250 VDC, 500 Vdc, and 1,000 Vdc	100 Vdc, 250 Vdc, 500 Vdc, and 1,000 Vdc
Insulation Resistance Range	0-2,000 MΩ and Infinity on all ranges	0-2,000 MΩ and Infinity on all ranges
Continuity Range	0-4 Ω range	0-4 Ω range
Power Source	Hand driven	Six 1.5-Vdc batteries
Terminal Voltage on Open Circuit	8 V ± 5%	5 V ± 5%
Terminal Current on Short Circuit	240 mA ± 10%	230 mA ± 10%
Circuit Discharge	Auto discharge of capacitive circuits when TEST button is released following an insulation test	Auto discharge of capacitive circuits when TEST button is released following an insulation test

- Totalize event indications. This is similar to measuring the frequency except that a manual or electronic start-stop gate controls the time over which the measurement is taken.
- Provide scaling in the form of a digital output signal from the electronic counter that represents a frequency-related division of the input frequency. Scaling is used for triggering other test equipment that is used in conjunction with the electronic counter.

Depending on the manufacturer and options, certain electronic counters also can measure the following characteristics of a signal:

- voltage measurement,
- pulse width,
- rise/fall time, and
- peak voltage levels of a signal.

Because of the wide variety of electronic counters in use in the fleet, the technical manual for a specific electronic counter should be consulted to determine the actual capabilities of the instrument.

### **Time Bases**

One of the first considerations in any measuring device is the standard it uses for comparison. This

standard must be accurate and it must maintain accuracy over time. When measuring frequency, a standard frequency source is needed for comparison. The standard for frequency used in electronic counters is an internal crystal oscillator that generates a standard frequency of 1, 5, or 10 MHz. Most electronic counters employ an oven oscillator feature whereby the oscillator is powered whenever the power line is connected even if the counter is not turned on. Keeping the counter connected to power when it is not being used avoids the need for a warm-up phase prior to using. This helps to ensure that the oscillator frequency remains stable. Most electronic counters have rear connection for the use of an external oscillator signal when a more accurate time base is desired or if the internal oscillator has failed.

### **Types of Electronic Counters**

The Navy uses two types of electronic counters—the conventional counter and the reciprocal counter. Both operate basically the same, however minor differences do exist.

**CONVENTIONAL COUNTER.**—The conventional counter is a digital electronic device, which measures the frequency of an input signal by counting the number of cycles (n) and dividing it by the time interval (t). The basic block diagram of the

conventional counter in its frequency measurement mode is shown in figure 6-5.

The input signal is initially conditioned to a format that is compatible with the internal circuitry of the counter. The conditioned signal that appears at the main gate is a pulse train where each pulse corresponds to one cycle or event of the input signal. When the main gate is open, pulses can pass through to be totalized by the counting register. The time base controls the opening and closing of the main gate, and the time base divider takes the time base signal as the input and provides as an output a pulse train whose frequency is variable in decade steps made selectable by the counter's gate time selector switch. The number of pulses totaled by the counting register for the selected gate time yields the frequency of the input signal. The frequency counted is then displayed on a digital readout.

**RECIPROCAL COUNTER.**—The block diagram of a reciprocal counter, shown in figure 6-6, is very similar to the block diagram of the conventional counter except that the reciprocal counter has separate registers for time and event counts and has an additional arithmetic circuit. The reciprocal counter always makes a period measurement of the input signal, and the counter computes and displays the frequency of the input signal by taking the reciprocal of the period measurement if a frequency measurement is required. The event register accumulates counts from the input signal, while, at the same time, the time register accumulates counts from the time base for as long as the main gate remains open. During a single-period measurement the main gate stays open for one period of

the input signal. During this time interval, the event register would have accumulated one count while the time register would have accumulated a number of clock pulses from the time base oscillator. The number of accumulated clock pulses is then multiplied by the clock period to give the period of the input signal. The reciprocal of this measurement is the frequency of the input signal. These mathematical computations are performed in the arithmetic circuit and the resultant is displayed on a digital readout.

### Model 5334A/B Electronic Counter Characteristics

The 5334A/B electronic counter, shown in figure 6-7, is of the reciprocal type configuration. Basic functions of the 5334A/B electronic counter include frequency, period, time interval, time interval delay, time interval averaging, ratio, and totalize. It has the following measurement capabilities:

- 100-MHz frequency range on input channels A and B.
- 2-nanosecond, single-shot time interval resolution.
- Frequency and period resolution of nine digits per second of gate time.
- Continuously adjustable gate time from 1 millisecond to 99.999 seconds in millisecond increments.
- With the addition of optional input channel C, a 1.3-GHz frequency range.

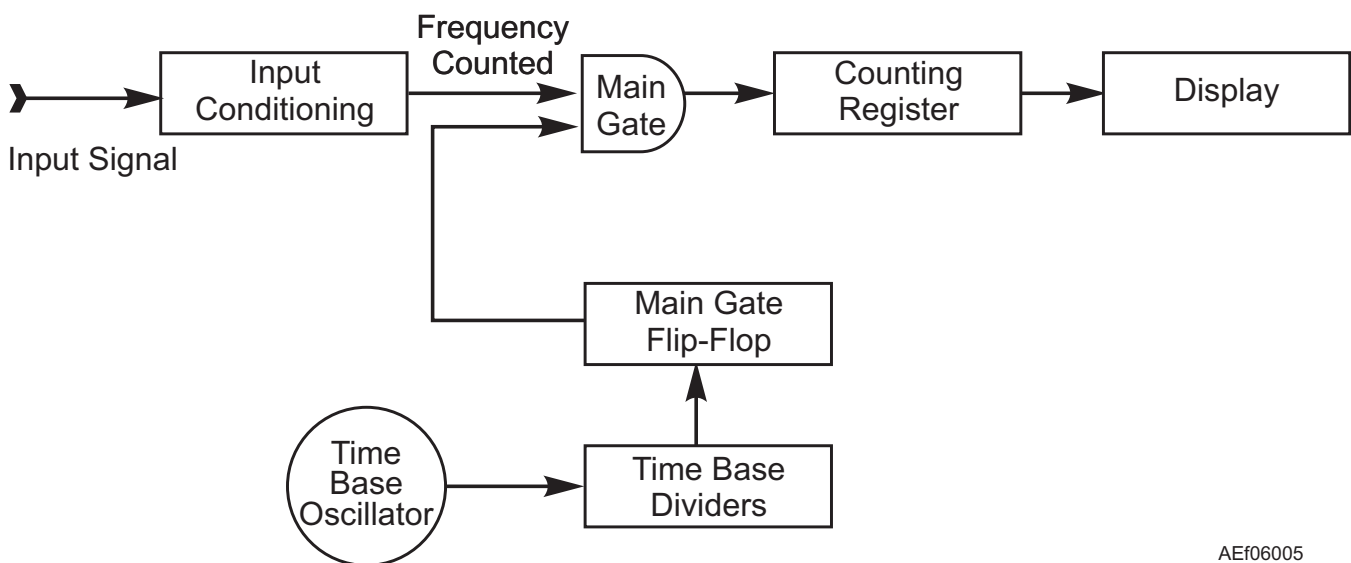
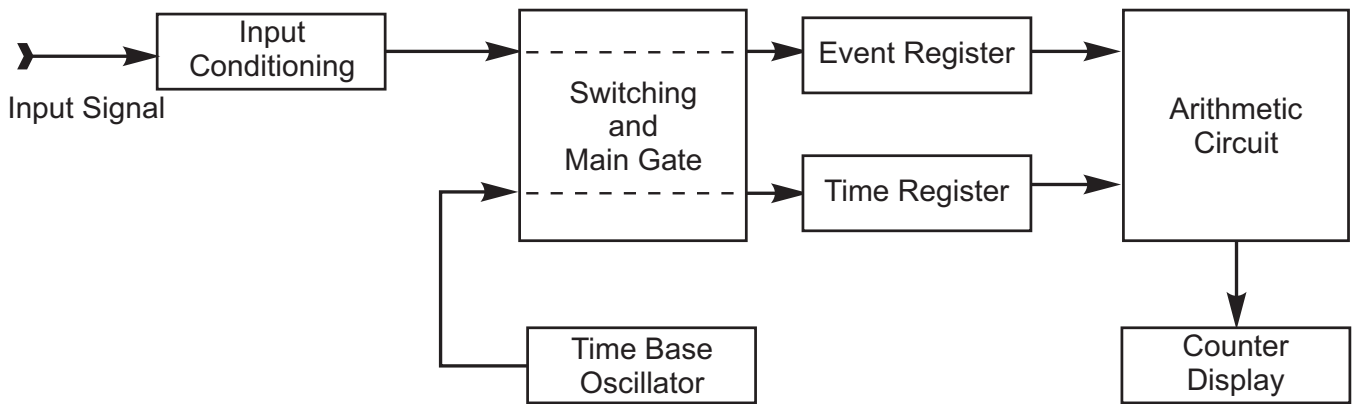

Figure 6-5.—Block diagram of conventional counter.



AEf06006

Figure 6-6.—Block diagram of reciprocal counter.

- An internal microcomputer that calculates the rms of all measurements and mathematical calculations, automatically taking into account the selected gate time. If the frequency of the input signal is desired, the counter computes and displays the frequency by taking the reciprocal of the period measurement.
- A counter that can save and recall up to nine different front panel setups by using nonvolatile memory.

The counter is fully programmable. Front panel features including gate time, trigger levels, and sensitivity can be selected through the instrument interface bus. This interface bus permits remotely programmed measurement results to be outputted to additional test equipment or computers.

**FREQUENCY FUNCTION.**—The frequency function is the most common measurement performed



Figure 6-7.—5334A/B electronic counter.

**Table 6-6.—Steps for Measuring Signals from 1mHz to 100 MHz**

STEP	ACTION
1	Press power switch to ON position.
2	Press COM A key to (separate) position (LED off) for separate inputs; COMMON position (LED on) for common inputs.
3	Connect signal to be measured to INPUT A or B connector.
4	Press corresponding function key (FREQ A or B).
5	Press AC/DC, 50 $\Omega$ or 1M $\Omega$ Impedance, and SLOPE keys to appropriate positions.
6	Press SENS key to SENSITIVITY position (LED on); rotate TRIGGER LEVEL/SENS control fully counterclockwise. This sets the trigger level to 0 volts and sensitivity to minimum.
7	Adjust TRIGGER LEVEL/SENS control in clockwise direction until a stable measurement is displayed.

by electronic counters. Tables 6-6 and 6-7 list the basic steps for measuring frequencies up to 100 MHz and 1.3 GHz, respectively. Refer to figure 6-7 when reviewing tables 6-6 and 6-7.

**NOTE:** Make sure the amplitude of the signal being measured does not exceed 1V rms dynamic range or damage will result to the electronic counter.

**PERIOD FUNCTION.**—The period function has high-resolution and low-frequency measurement capabilities. The period of a signal is the time required for one complete cycle of a regular, repeating series of events. Table 6-8 lists the steps for making period measurements. Refer to figure 6-7 when reviewing table 6-8.

**TIME INTERVAL FUNCTION.**—The time interval function measures the time difference from the START to STOP channel. In the time interval mode the

counter will measure the time from the first event in either channel to the first event in the other channel. Table 6-9 lists the steps for taking time interval measurements. Refer to figure 6-7 when reviewing table 6-9.

**TIME INTERVAL DELAY FUNCTION.**—Time interval delay function measurements are made in the same manner as time interval measurements except that in Step 3 (see table 6-9) the T.I. A→B (DELAY) function key is pressed instead of the T.I. A→B function key.

**TIME INTERVAL AVERAGING FUNCTION.**—Time interval averaging measurements are made in the same manner as time interval measurements except that after Step 6 (see table 6-9) the 100-GATE Average key is pressed, which only displays the measurement after the gate has cycled 100 times and is completely dependent on the gate time setting.

**Table 6-7.—Steps for Measuring Signals from 90 MHz to 1.3 GHz**

STEP	ACTION
1	Press power switch to ON position.
2	Connect signal to be measured to INPUT C connector.
3	Press function key FREQ C.
4	Set INPUT C SENSITIVITY control to minimum, fully counterclockwise. Slowly rotate the control in a clockwise direction until the GATE light turns on.
5	Adjust GATE TIME setting for preferred resolution and view display.

**Table 6-8.—Steps for Making Period Measurements**

STEP	ACTION
1	Press power switch to ON position.
2	Press COM A key to (separate) position (LED off).
3	Connect signal to be measured to INPUT A connector.
4	Press PERIOD A function key.
5	Set AC/DC, 50 $\Omega$ or 1M $\Omega$ Impedance, and SLOPE keys to appropriate positions.
6	Press SENS key to SENSITIVITY position (LED on); rotate TRIGGER LEVEL/SENS control fully counter clockwise. This sets the trigger level to 0 volts and sensitivity to minimum.
7	Adjust TRIGGER LEVEL/SENS control in clockwise direction until a stable measurement is displayed.

**Table 6-9.—Steps for Making Time Interval Measurements**

STEP	ACTION
1	Press power switch to ON position.
2	Connect START signal to INPUT A connector and STOP signal to INPUT B connector and press COM A key to (separate) position (LED off) for separate inputs; COMMON position (LED on) for common inputs.
3	Press T.I. A→B function key, and press AUTO TRIG off.
4	Press AC/DC, 50 $\Omega$ or 1M $\Omega$ Impedance, and SLOPE, and X10 ATTN keys to appropriate positions.
5	Press SENS key to (TRIGGER LEVEL) position (LED off). This sets the sensitivity to maximum, and allows variable selection of trigger levels.
6	Adjust TRIGGER LEVEL/SENS for optimum triggering, usually midrange and view display.

**RATIO A/B FUNCTION.**—The ratio mode of operation measures the ratio between the two frequencies. The counter displays the frequency ratio of the signal on Channel A in relation to the signal on Channel

B. For ratio displays greater than one, the higher frequency should be connected to Channel A. The major application for ratio function is the measurement of harmonically related signals. Table 6-10 lists the

**Table 6-10.—Steps for Making Ratio Measurements**

STEP	ACTION
1	Press power switch to ON position.
2	Press COM A key to (separate) position (LED off).
3	Connect signals to INPUT A and B connectors.
4	Press RATIO A/B function key, and press AUTO TRIG off.
5	Set AC/DC, 50 $\Omega$ or 1M $\Omega$ Impedance, and SLOPE, and X10/(X1) ATTN keys to appropriate positions.
6	Press SENS key to SENSITIVITY position (LED on); rotate TRIGGER LEVEL/SENS control fully counterclockwise. This sets the trigger level to 0 volts and sensitivity to minimum.
7	Adjust TRIGGER LEVEL/SENS control in clockwise direction until a stable measurement is displayed.

steps required for making ratio measurements. Refer to figure 6-7 when reviewing table 6-10.

**TOTALIZE FUNCTION.**—The totalize mode of operation displays the number of counts or events received through INPUT A while the gate is open. The count is continuously displayed and accumulated from input cycle to cycle. Table 6-11 lists the required steps for making totalize measurements. Refer to figure 6-7 when reviewing table 6-11.

For detailed operating instructions and additional measurement capabilities of this instrument, refer to the manufacturer’s operating manual.

- Q6-17. *Electronic counter can measure frequency up to what maximum value?*
- Q6-18. *What are at least three measurement functions an electronic counter can perform in addition to frequency measurements?*
- Q6-19. *What is the heart of an electronic counter?*
- Q6-20. *By what means is the crystal oscillator frequency kept stable when the electronic counter is not being used?*
- Q6-21. *What are two types of counters used by the Navy?*
- Q6-22. *What is the major difference between the two types of counters?*

Q6-23. *With channel C option on the 5334A the electronic counter is capable of measuring up to what frequency?*

Q6-24. *What is the major application for ratio A/B function?*

**POWER METERS**

Power meters are used to monitor transmitter power levels, level power sources, and calibrate signal generators. For example, at microwave frequencies, power is the best measure of signal amplitude because, unlike voltage and current, power remains constant along a transmission line that has no losses. For this reason the power meter is the preferred instrument for making microwave measurements. Power meters use thermocouples, diodes, or thermistors as their power-sensing elements.

**Thermocouple Power Sensors**

Thermocouple power sensors are generally preferred because they offer lower standing wave ratio (SWR) and wider dynamic range than thermistor sensing elements. Low SWR and improved stability account for more accurate measurements because mismatch error is reduced. Thermocouple sensors are available for frequencies from 100 kHz to 110.0 GHz, depending on the model of sensor used.

**Table 6-11.—Steps for Making Totalize Measurements**

<b>STEP</b>	<b>ACTION</b>
1	Press power switch to ON position.
2	Press COM A key to (separate) position (LED off).
3	Connect signal to INPUT A connector.
4	Press TOT START A function key, AUTO TRIG will turn off automatically.
5	Set AC/DC, 50 Ω or 1MΩ Impedance, and SLOPE, and X10/(X1) ATTN keys to appropriate positions.
6	Press SENS key to SENSITIVITY position (LED on); rotate TRIGGER LEVEL/SENS control fully counter clockwise. This sets the trigger level to 0 volts and sensitivity to minimum.
7	Adjust TRIGGER LEVEL/SENS control in clockwise direction until Channel A trigger light begins to flash.
8	Press RESET to clear display.
9	Press TOT START A to start a totalize measurement; press TOT STOP A to stop totalizing. Press RESET to clear display and begin a new measurement.



## Diode Power Sensors

Diode power sensors are usually interchangeable with power meters that use thermocouple power sensors. This type of sensor can extend the power meter's input level down to -70 dBm (100 picowatts [Pw]). Sensors of this type use a Low-Barrier Schottky Diode to achieve sensitivity and to achieve low-noise and drift characteristics. This diode is operated in its square law region for best results. This type of sensor can be used to measure the true power of complex or continuous wave (CW) waveforms. Diode sensors are available for frequencies from 100 kHz to 110.0 GHz, depending on the model of sensor used.

## Thermistor Power Sensors

Older type power meters use thermistor power sensors. These power meters are based on balanced bridge principles; they are used whenever a direct substitution method is required. Thermistor power sensors are temperature compensated for low drift and permit the measurement of microwave power as low as one microwatt. The frequency ranges of these sensors are from 10 MHz to 40.0 GHz, depending on the model of sensor used.

## 436A Power Meter

The 436A power meter, shown in figure 6-8, is a general-purpose digital power meter capable of

automatic and manual measurement RF and microwave power levels. It operates in conjunction with Hewlett Packard (HP) 8480 power sensor series. The specific power sensor selected for use determines the frequency and power range of the instrument. Depending on which power sensor is used, the 436A has the capability of measuring power from -70 dBm (100 pW to +44 dBm (25 W) at frequencies from 100 kHz to 110 GHz. For proper power meter operation, the power sensor must be connected to the power meter with the power sensor cable supplied with the test instrument or another power sensor cable made by the same manufacturer. These special power sensor cables make use of a sensitivity line to enable the power meter to determine the operating range of the power sensor and therefore the true value of the input signal being measured.

The 436A power meter uses push-button front panel controls and a large four-digit digital display with an analog peaking meter to show fast changes in power levels for working with variable power devices. Readings can be made in absolute power, which will be displayed in either watts or dBm. A technician can use the decibel reference switch to measure relative power. Pressing this switch zeros the display for any applied input power and any deviation from this reference is shown in dB  $\pm$  0.01dB. A rear interface bus allows full remote control operation of all power meter functions and permits measurement results to be outputted to compatible test equipment and or computers.



Figure 6-8.—Model 436A power meter.

Table 6-12 lists the proper steps to take to make power measurements. Refer to figure 6-8 when reviewing table 6-12.

- Q6-25. *What is the preferred instrument to be used to make microwave power measurements?*
- Q6-26. *Name the three types of power sensing elements used in conjunction with power meters.*
- Q6-27. *The diode type power sensor is operated in its square law region for what purpose?*
- Q6-28. *What is the frequency range of thermocouple and diode power sensors?*

## OSCILLOSCOPES

The primary use of an oscilloscope is in troubleshooting and aligning electronic equipment. You do this by observing and analyzing waveform shape, amplitude, and duration. The maintenance instruction manual (MIM) for the particular equipment being tested specifies the waveforms that you should observe when you check the test points throughout the equipment. Waveforms at a test point may differ from

the one shown in the MIM, depending on whether the operation of the equipment being tested is normal or abnormal.

The oscilloscope is a graph-displaying device that shows a graph of an electronic signal. In most applications, the graph shows how signals change over time; the horizontal X-axis represents time and the vertical Y-axis represents amplitude. The intensity or brightness of the display is usually called the *Z-axis*. See figure 6-9. This simple graph can tell you many things about a signal. For example, you can:

- determine the time and voltage of a signal,
- calculate the frequency of an oscillating signal,
- see the “moving parts” of a circuit represented by the signal,
- tell how often a particular portion of the signal is occurring relative to other portions,
- tell if a malfunctioning component is distorting the signal,
- find out how much of a signal is made up of direct current dc and/or ac, and

**Table 6-12.—Steps for Making Power Measurements**

STEP	ACTION
1	Connect the power sensor and power sensor cable to the power meter.
2	Connect the power sensor to the Power Reference output connector.
3	Connect the power cable to the power meter and power outlet, and set the line switch to ON (depressed).
4	Set the remaining power meter switches to as follows: Calibration Factor % = 100; Power Reference = OFF (out); Mode = WATT; Range Hold = OFF (out).
5	Press and hold the Sensor Zero switch and wait for the digital display to stabilize. Then verify that the Zero lamp is lit and that the digital display indicates $0.00 \pm 0.02$ .
6	Release the Sensor Zero switch and wait for the Zero lamp to go out.
7	Connect the power sensor to the Power Reference Output connector and set the Power Reference switch to ON (in). Then adjust the Cal Adjust control so that the digital readout indicates 1.000 mW.
8	Set Power Reference switch to OFF (out) and disconnect the power sensor from the Power Reference Output connector.
9	Locate the calibration curve on the outside of the power sensor and determine the Calibration Factor for the frequency to be measured; set the power meter Calibration Factor % switch accordingly.
10	Set the Mode and Range Hold switches for desired measurement and connect the power sensor to the RF source to be measured.

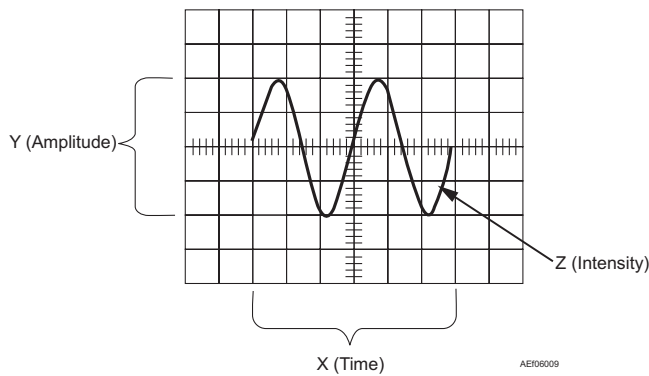

Figure 6-9.—X, Y, Z components of a displayed waveform.

- tell how much of the signal is made up of noise and whether the noise is changing with time.

An oscilloscope’s front panel includes a display screen and the knobs, buttons, switches, and indicators used to control signal acquisition and display. The panel has controls that are divided into three major sections—vertical, horizontal, and trigger—with associated display controls. The panel also has input connectors to connect to the signals to be measured.

### Types Of Oscilloscopes

Electronic equipment can be divided into two types: analog and digital. Analog equipment works with continuously variable voltages, while digital equipment works with discrete binary numbers that may represent voltage samples. For example, a watch with hour, minute, and second hands is an analog device while a watch with light-emitting diodes that display discrete hour, minute, and second numerals is a digital device. Oscilloscopes also come in analog and digital types. Further, there are three kinds of oscilloscopes, one is analog and two are digital—the conventional analog oscilloscope, the digitizing storage oscilloscope (DSO), and the digital phosphor oscilloscope (DPO). For many applications, either an

analog or digital oscilloscope will do. However, each type has unique characteristics that may make it more or less suitable for specific tasks. A conventional analog oscilloscope, a DSO, and a DPO have some identical internal circuitry even though each works somewhat differently.

**ANALOG OSCILLOSCOPE.**—An analog oscilloscope works by applying the measured signal voltage directly to an electron beam moving across the oscilloscope screen (usually a CRT). The backside of the screen is treated with a coating of phosphor (a layer of luminescent material) that, when bombarded by electrons, fluoresces (emits light when excited by electrons), and after the bombardment it phosphoresces (glows) whenever the electron beam hits it. The signal voltage deflects the beam up and down proportionally, tracing the waveform on the screen. The more frequently the beam hits a particular screen location, the more brightly it glows. This in turn gives an immediate picture of the waveform.

Technicians often prefer an analog oscilloscope when it is important to display rapidly varying signals in “real time” (as they occur). An analog scope’s chemical phosphor-based display has a characteristic known as *intensity grading* that makes the trace brighter wherever the signal features occur most often. This makes it easy to distinguish signal details just by looking at the trace intensity levels.

The CRT limits the range of frequencies an analog scope can display. At very low frequencies, the signal appears as a bright, slow-moving dot that’s difficult to distinguish as a waveform. At high frequencies, the CRT writing speed defines the limit. When the signal frequency exceeds the CRT writing speed, the display becomes very dim and hard to see. The fastest analog scopes can display frequencies up to about 1 GHz.

When you connect an oscilloscope probe to a circuit, the voltage signal travels through the probe to the vertical system of the oscilloscope. Figure 6-10 is a

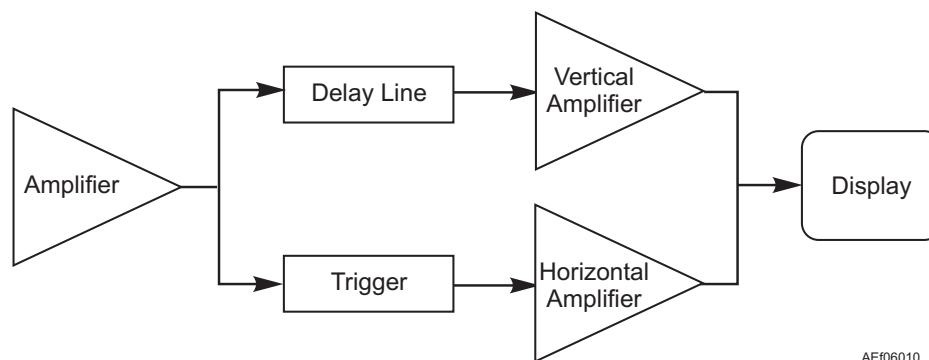

Figure 6-10.—Analog oscilloscope block diagram.

simplified block diagram that shows how an analog oscilloscope displays a measured signal.

Depending on how you set the vertical scale (VOLTS/DIV control), an attenuator reduces the signal voltage or an amplifier increases the signal voltage. Next, the signal travels directly to the vertical deflection plates of the CRT. Voltage applied to these deflection plates causes a glowing dot to move. (An electron beam hitting the phosphor inside the CRT creates the glowing dot.) A positive voltage causes the dot to move up while a negative voltage causes the dot to move down.

The signal also travels to the trigger system to start or trigger a horizontal sweep. *Horizontal sweep* is a term referring to the action of the horizontal system causing the glowing dot to move across the screen. Triggering the horizontal system causes the horizontal time base to move the glowing dot across the screen from left to right within a specific time interval. Many sweeps in rapid sequence cause the movement of the glowing dot to blend into a solid line. At higher speeds, the dot may sweep across the screen up to 500,000 times each second.

Together, the horizontal sweeping action and the vertical deflection action traces a graph of the signal on the screen. The trigger is used to stabilize a repeating signal. It ensures that the sweep begins at the same point of a repeating signal, resulting in a clear picture.

When using an analog oscilloscope, you need to adjust three basic settings to accommodate an incoming signal when the scope is not capable of making the settings automatically:

1. The attenuation or amplification of the signal. Use the VOLTS/DIV control to adjust the amplitude of the signal to the desired measurement range.
2. The time base. Use the SEC/DIV control to set the amount of time per division represented horizontally across the screen.
3. The triggering of the oscilloscope. Use the trigger level to stabilize a repeating signal or to trigger on a single event.

In addition, adjust focus and intensity controls to create a sharp, legible display.

### DIGITIZING STORAGE OSCILLOSCOPE

**(DSO).**—The conventional digitizing scope is known as a DSO. DSOs allow you to capture and view events that may happen only once. Because the waveform information is in digital form (a series of stored binary values), it can be analyzed, archived, printed, and otherwise processed, within the scope itself or by the use of an external computer. The waveform doesn't need to be continuous; even when the signal disappears, it still can be displayed. However, DSOs have no real-time intensity grading, therefore they cannot express varying levels of intensity in a live signal.

A DSO uses an analog-to-digital converter (ADC) to convert the voltage being measured into digital information. The scope can display any frequency within its range with equal stability, brightness, and clarity. The digitizing oscilloscope frequency range is determined by its sample rate, assuming that its probes and vertical sections are adequate for the task. The scope acquires the waveform as a series of samples. It stores these samples until it accumulates enough samples to describe a waveform, and then reassembles the waveform for viewing on the screen. Its display doesn't rely on luminous phosphor; instead, it uses a raster-type screen. Some of the systems that make up DSOs are the same as those in analog oscilloscopes; however, DSOs contain additional data processing systems. See figure 6-11. With these added systems, the DSO collects data for the entire waveform and then displays it all at once.

The first (input) stage of a DSO is a vertical amplifier, just like the analog scope. Vertical attenuation controls allow you to adjust the amplitude range of this stage. The ADC in the acquisition system samples the signal at discrete points in time and converts the signal voltage at these points to digital values called sample points. The horizontal system's sample clock determines how often the ADC takes a sample. The rate at which the clock "ticks" is called the sample rate and is expressed in samples per second. The sample points from the ADC are stored in memory as waveform points. More than one sample point may

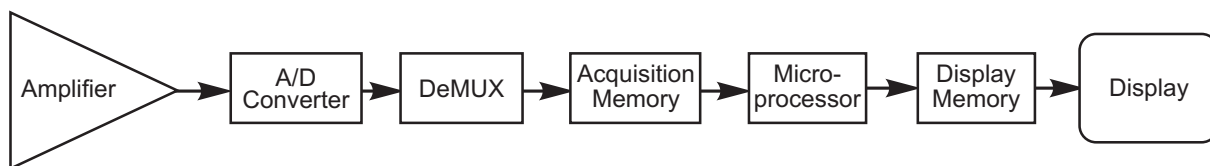

Figure 6-11.—Digitizing storage oscilloscope block diagram.

AEF06011

make up one waveform point. Together, the waveform points make up one waveform record. The number of waveform points used to make a waveform record is called the record length. The trigger system determines the start and stop points of the record. The display receives these record points after being stored in memory.

Depending on the capabilities of the oscilloscope, additional processing of the sample points may take place, enhancing the display. Pretriggering may be available, allowing you to see events before the trigger point.

Note that the DSO signal path includes a microprocessor. The measured signal passes through this device on its way to the display. In addition to processing the signal, the microprocessor coordinates display activities, manages the front panel controls, and more. This is known as a *serial processing* architecture.

**DIGITAL PHOSPHOR OSCILLOSCOPE (DPO).**—The DPO (see fig. 6-12) has another oscilloscope architecture. Like the analog scope, its first stage is a vertical amplifier; like the DSO, its second stage is an ADC. But after the analog-to-digital conversion, the DPO looks quite different from the DSO. It has special features designed to recreate the intensity grading of an analog CRT.

The scope can display any frequency within its range with equal stability, brightness, and clarity. The scope's frequency range is determined by its sample rate, assuming that its probes and vertical sections are adequate for the task. The DPO emulates the best display attributes of the analog scope and provides the benefits of digital acquisition and processing as well. Like the DSO, the DPO uses a raster screen. But instead of a phosphor, it employs special parallel processing circuitry to deliver a crisp, intensity-graded trace.

The DPO breaks down the barrier between analog and digitizing scope technologies. It is equally suitable for viewing high frequencies or low, repetitive waveforms, transients, and signal variations in real time. The DPO provides the Z-axis (intensity) that's missing from DSOs.

Rather than relying on a chemical phosphor as an analog scope does, the DPO has a purely electronic digital phosphor that's actually a continuously updated database. This database has a separate *cell* of information for every single pixel in the scope's display. Each time a waveform is captured (in other words, every time the scope triggers), it is mapped into the digital phosphor database's cells. Each cell representing a screen location that is touched by the waveform gets reinforced with intensity information. Others do not. Thus, intensity information builds up in cells where the waveform passes most often.

When the digital phosphor database is fed to the oscilloscope display, the display reveals intensified waveform areas, in proportion to the signal's frequency of occurrence at each point, much like the intensity grading characteristics of an analog oscilloscope. Unlike an analog scope, the DPO allows the varying levels to be expressed in contrasting colors, if desired. With a DPO, it's easy to see the difference between a waveform that occurs on almost every trigger and a waveform that occurs only every 100th trigger.

The DPO uses a parallel processing architecture to achieve this manipulation without slowing down the whole acquisition process. Like the DSO, the DPO uses a microprocessor for display management, measurement automation, and analysis. But the DPO microprocessor is outside the acquisition and display signal path where it doesn't affect the acquisition speed.

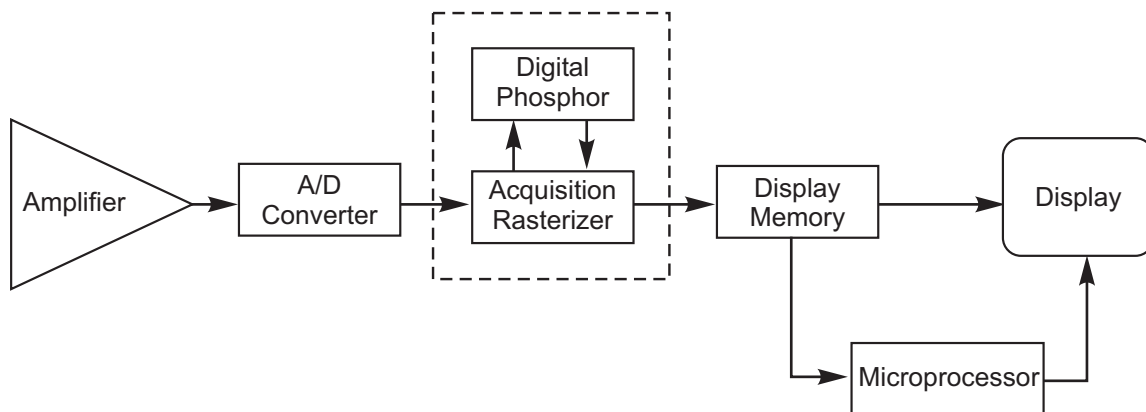

Figure 6-12.—Digital phosphor oscilloscope block diagram.

AE06012

## Model 2246 Portable Oscilloscope

The Model 2246 (see fig. 6-13) is a 100-MHz, four-channel, portable analog oscilloscope for general-purpose use.

**MODEL 2246 DESCRIPTION.**—A microprocessor-based operating system controls most of the functions of the Model 2246 oscilloscope including a fully integrated menu-driven display system along with on-screen vertical and horizontal cursors which provide accurate voltage, time, frequency, and phase measurements. This oscilloscope also has a menu-driven service model for internal calibration and diagnostic testing.

The vertical deflection system has four input channels. Channels 1 and 2 have 11 basic deflection factors from 2 mV to 5 V per division, and channels 3 and 4 have 2 basic deflection factors of 0.1 V and 0.5 V per division. Basic deflection factors can be extended with the use of attenuator probes when necessary. VOLTS/DIV readouts are switched to display the correct vertical scale factors when compatible probes

recommended by the manufacturer are connected to the vertical input connectors.

The horizontal deflection system provides single, dual, or delayed sweeps from 0.05 seconds to 20 nanoseconds per division (delayed sweep 5 milliseconds to 20 nanoseconds per division). The trigger system provides stable triggering over the entire bandwidth of the vertical deflection system.

**OSCILLOSCOPE MEASURING TECHNIQUES.**—The two most basic measurements you can make with an oscilloscope are amplitude and time. Almost every other measurement is based on one of these two fundamental techniques. Since the oscilloscope is a voltage-measuring device, voltage is shown as amplitude on your screen. Amplitude is best measured when the signal covers most of the screen vertically. Time measurement is more accurate when the signal covers a large area of the screen horizontally. The more screen area that is used, the better the measurement resolution is achieved. Tables 6-13 and 6-14 list the general steps you should take when making amplitude and time measurements, respectively, with



Figure 6-13.—Model 2246 portable oscilloscope.

**Table 6-13.—Steps for Making Amplitude Measurements**

<b>STEP</b>	<b>ACTION</b>
1	Connect probe or cable (depending on the measurement) to Channel 1 connector. If using a probe make sure that it is compensated, and ensure all variable (CAL) controls are in their detent positions.
2	Set VERTICAL MODE switch to Channel 1 and the Channel 1 input-coupling switch to AC. The TRIGGER MODE switch should be set to NORM for normal triggering, and the TRIGGER SOURCE switch set to Channel 1.
3	Connect the signal to be measured via the probe or cable and adjust the TRIGGER LEVEL control to obtain a stable trace while adjusting the Channel 1 VOLTS/DIV switch until the signal is about 5 divisions high. Now adjust the SEC/DIV switch until about one cycle of the waveform is displayed on the screen.
4	Use the Channel 1 POSITION control to move the waveform so that its bottom is aligned with a convenient horizontal graticule line that allows you to approximately center the waveform vertically. Use the HORIZONTAL COARSE POSITION control to move the signal so that either the top or the bottom of the cycle intersects the center graticule line.
5	Now count the major and minor divisions up the center vertical graticule line and multiply by VOLTS/DIV setting. The result is the amplitude of the signal.

the Model 2246 oscilloscope. Refer to figure 6-13 when reviewing tables 6-13 and 6-14.

- Q6-29. What is the primary function of an oscilloscope?*
- Q6-30. Name the three axes of a typical oscilloscope?*
- Q6-31. What do the three axes of an oscilloscope represent?*
- Q6-32. Identify at least four items of information that an oscilloscope can tell you about a signal?*
- Q6-33. All electronic equipment can be classified into one of what two information categories?*
- Q6-34. On an analog oscilloscope, what happens when the signal being analyzed exceeds the frequency range of the oscilloscope?*
- Q6-35. What are the three kinds of oscilloscopes?*

**Table 6-14.—Steps for Making Time and Frequency Measurements**

<b>STEP</b>	<b>ACTION</b>
1	Connect probe or cable (depending on the measurement) to Channel 1 connector. If using a probe make sure that it is compensated, and ensure all variable (CAL) controls are in their detent positions.
2	Set VERTICAL MODE switch to Channel 1 and the Channel 1 input-coupling switch to AC. The TRIGGER MODE switch should be set to NORM for normal triggering, and the TRIGGER SOURCE switch set to Channel 1.
3	Connect the signal to be measured via the probe or cable and adjust the TRIGGER LEVEL control to obtain a stable trace while adjusting the Channel 1 VOLTS/DIV switch until the signal is about 5 divisions high. Now adjust the SEC/DIV switch until about one cycle of the waveform is displayed on the screen.
4	Use the Channel 1 POSITION control to move the waveform so that its bottom is aligned with a convenient horizontal graticule line that allows you to approximately center the waveform vertically.
5	Now with the HORIZONTAL COURSE and FINE POSITION controls, position a rising edge of the signal being measured with the second graticule line from the left side of the screen. Use the HORIZONTAL COARSE POSITION control to move the signal so that either the top or the bottom of the cycle intersects the center graticule line.

- Q6-36. What determines the frequency range of a digitizing oscilloscope?
- Q6-37. What advantage does a digitizing storage oscilloscope have over other kinds of oscilloscopes?
- Q6-38. When an electrical signal is measured with an analog oscilloscope, what section of the oscilloscope controls the attenuation or amplification of the signal being analyzed?
- Q6-39. What section of an analog oscilloscope is used to stabilize a repeating signal?
- Q6-40. What type of oscilloscope uses serial processing?
- Q6-41. (True or false) The amplitude of a signal is best measured when the signal covers most of the oscilloscope screen horizontally.
- Q6-42. (True or false) Time measurements of a signal are best measured when the signal covers most of the oscilloscope screen horizontally.

## SPECTRUM ANALYZER

When a wave (called a carrier) is modulated by varying the amplitude, frequency, or phase so it varies in step with another wave (called a modulating wave), the resulting wave contains many frequencies. The original carrier is present together with two groups of new frequencies (sideband components). One group of sidebands is displaced in frequency below the carrier. The other group is displaced above the carrier. The distribution of these frequencies can be shown on a graph of amplitude plotted on the vertical or (X-axis) against frequency plotted on the horizontal or (Y-axis) as shown below in figure 6-14. The overall pattern of this display indicates the proportion of power present in the various frequencies within the spectrum of the wave (fundamental frequency with sideband frequencies).

A spectrum analyzer is a device used to display the spectrum of modulated waves in the radio frequency range and the microwave region. Communications and radar technicians are very interested in the harmonic make-up of signal. Proper interpretation of the displayed frequency spectrum enables you to determine if equipment is operating properly and the degree of the efficiency of the equipment being tested. For example, radio systems must be checked for harmonics of the carrier signal that might interfere with other systems operating at the same frequencies of the harmonics. Technicians also are interested in distortion of the message modulated onto the carrier. Third-order

intermodulation (two tones of a complex signal modulating each other) can be especially troublesome because the distortion components can fall within the band of interest and not be filtered away properly. Examination of spectral occupancy is another important reason to use a spectrum analyzer. Modulation on a signal spreads its spectrum, and to prevent interference with adjacent signals, regulatory agencies restrict the spectral bandwidth of various transmissions.

Figure 6-15 is a simplified block diagram of a superheterodyne spectrum analyzer. *Heterodyne* means to mix or translate the frequency, and *super* refers to super-audio frequencies, or frequencies above the audio range. In the block diagram, the input signal passes through a low pass filter to a mixer, where it mixes with a signal from the local oscillator (LO). Because the mixer is a nonlinear device, its output includes not only the two original signals, but also their harmonics and the sums and differences of the original frequencies and their harmonics. If any of the mixed signals falls within the bandpass of the intermediate frequency (IF) filter, it is further processed, amplified, and then rectified by the detector. Following the detector, it is then applied to the vertical plates of the CRT to produce the vertical deflection on the CRT screen. The sawtooth generator deflects the CRT beam horizontally across the screen from left to right. The generator also tunes the LO so that its frequency changes in proportion to the ramp voltage of the sawtooth.

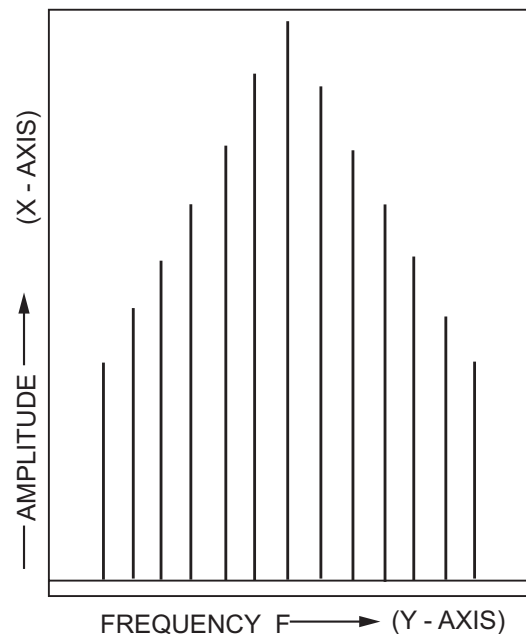

AEI06014

Figure 6-14.—Spectrum analyzer pattern.



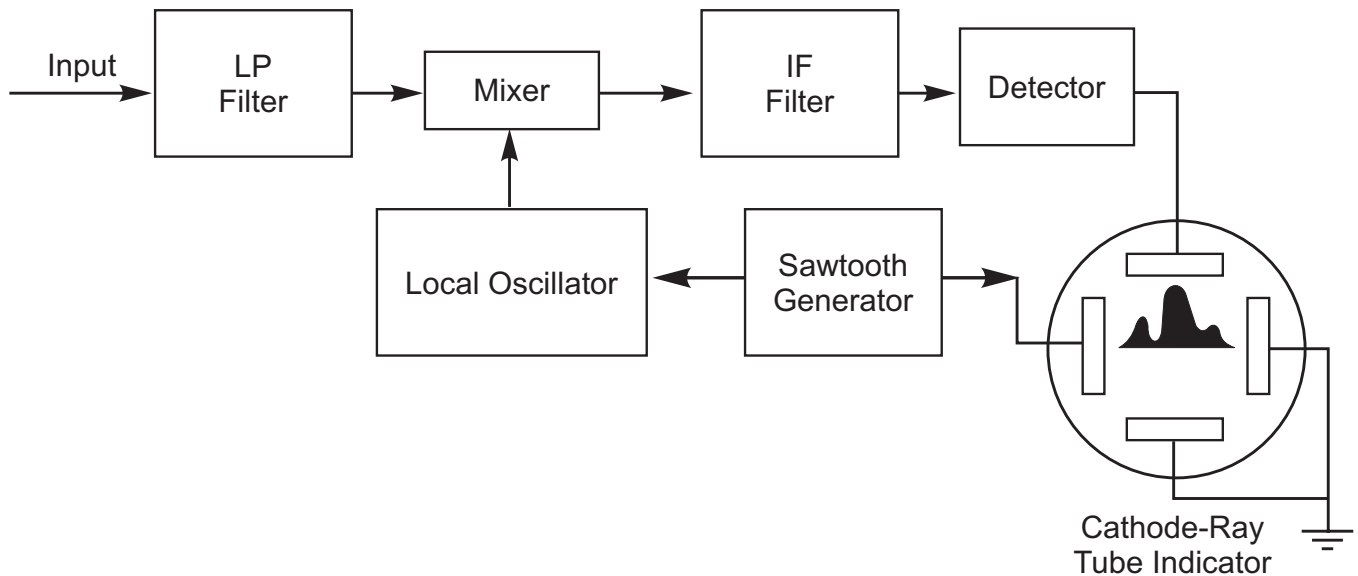

AEF06015

Figure 6-15.—Typical spectrum analyzer block diagram.

### Model 8562A/B Portable Spectrum Analyzer

The 8562A/B (fig. 6-16) portable spectrum analyzer is a small, lightweight, self-contained instrument that needs only an external ac power source for operation. The instrument is very easy to use and makes quick and accurate measurements of signals from -119.9 dBm to + 30 dBm over a frequency range of 1 kHz to 22 GHz. The frequency range of the

analyzer can be extended to 110 GHz by using HP 11970 series external harmonic mixers and to 325 GHz by using mixers from alternate manufacturers.

Basic functions of the unit include frequency, span, and amplitude. A menu-driven interface system makes the analyzer very easy to use. All measurements and settings are read directly from the CRT display with one-point measurement capability for quick results.



Figure 6-16.—Model 8562A/B spectrum analyzer.

Marker functions are available to determine frequencies and amplitudes along the spectrum analyzer trace that are used for making comparative measurements, automatically locate the highest amplitude signal on a trace, and automatically track a signal. A rear interface bus IEEE-488 allows full remote control operation of all analyzer functions and permits measurement results to be outputted to compatible test equipment and or computers.

### Spectrum Analyzer Measuring Techniques

Most transmitting devices and signal sources contain harmonics. Measuring the harmonic content of such sources is frequently required. In fact, measuring harmonic distortion is one of the most common uses of a spectrum analyzer. Harmonic distortion can be checked quickly using the measurement routine described in table 6-15, which measures harmonic amplitudes relative to the source frequency. The harmonic distortion measurement uses many of the skills required to use a spectrum analyzer: setting the frequency, setting span by using start and stop frequencies, setting the video bandwidth, and making measurements by using the markers, to name a few. The next steps will pertain to measuring a 300 MHz fundamental frequency and its first two harmonics.

Another way of determining percent of distortion is by using the spectrum analyzer instead of the chart. This can be accomplished by changing the measured units to VOLTS by pressing AMPLITUDE and then from the menu selecting MORE, UNITS, and VOLTS. The marker readout will automatically switch to voltage units. Then by using the ratio given by the marker, move the decimal place two positions to the right.

For more information about spectrum analyzers and proper measuring techniques, refer to the manufacturer's publication supplied with the instrument being used.

- Q6-43. *What are the two axes of a typical spectrum analyzer?*
- Q6-44. *What do the two axes represent?*
- Q6-45. *What information does a spectrum analyzer exhibit?*
- Q6-46. *What does the term heterodyne mean?*
- Q6-47. *The signal being measured by a typical spectrum analyzer is applied to what plates of a CRT?*
- Q6-48. *What is the power and frequency range of the 8562A/B spectrum analyzer?*

**Table 6-15.—Steps for Making Distortion Measurements**

STEP	ACTION
1	Connect the unit to an ac power source and depress the line switch to turn on the spectrum analyzer. Then connect the signal source to the spectrum analyzer's INPUT 50 Ω connector and depress the PRESET button.
2	Set the start frequency to 270 MHz and stop frequency to 1000 MHz. This will allow the display of the 300 MHz fundamental frequency and the second and third harmonics. To improve the visibility, depress the BW switch which will access a menu of bandwidth functions, depress the VIDEO BW then select the STEP ↓ key as desired. (See fig. 6-17).
3	For improved measurement accuracy raise the peak of the fundamental to the reference level by pressing PEAK SEARCH, MKR→, and then MKR→REF LVL from the menu. (See fig. 6-18).
4	To measure the difference between the fundamental and the second harmonic, activate a second marker by pressing PEAK SEARCH, and then from the menu, depress MARKER DELTA and NEXT PEAK. This will place the second marker on the peak of the second harmonic, as shown in figure 6-18. The difference between the fundamental and second harmonic shown in the figure is approximately – 45 dB, or 0.56 % harmonic distortion by using the chart in figure 6-19.
5	To measure the third harmonic, press NEXT PEAK again from the menu. The marker should read approximately – 50 dB, or .32 % distortion by using the chart in figure 6-19.

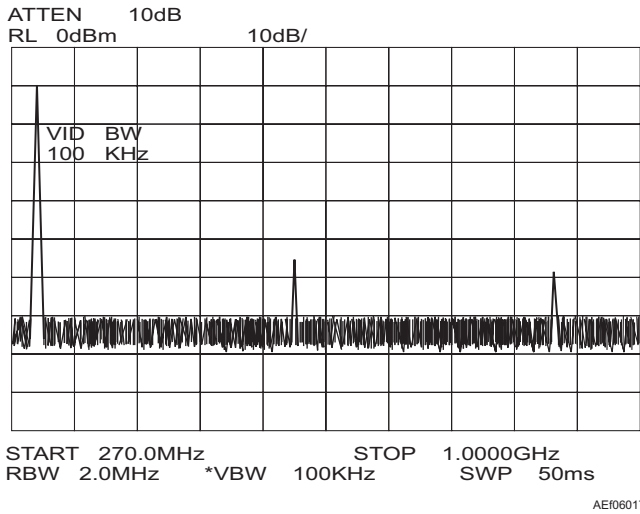

Figure 6-17.—300-MHz fundamental frequency and harmonics.

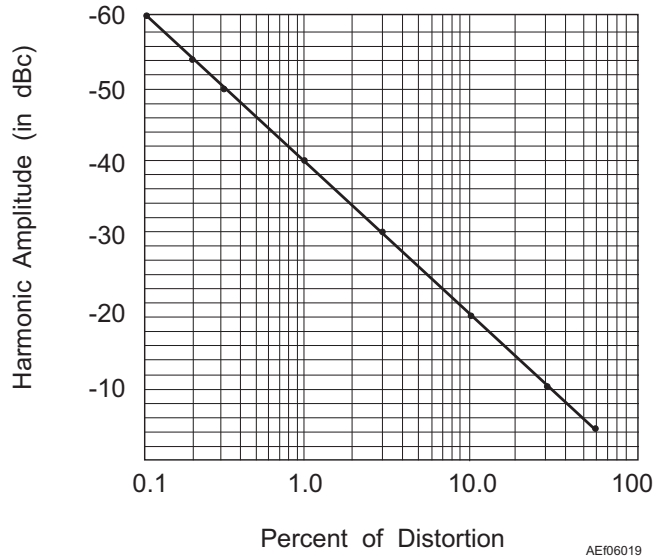

Figure 6-19.—Percent of distortion versus harmonic amplitude chart.

### CONSOLIDATED AUTOMATED SUPPORT SYSTEM (CASS)

**LEARNING OBJECTIVE:** Identify general features and basic configurations of a typical Consolidated Automated Support System (CASS).

Automatic test equipment (ATE), such as the AN/USM-636A(V)1 Consolidated Automated Support System (CASS), the AN/USM-484 Hybrid Test System (HTS), the AN/USM-467 Radar Communications Tester (RADCOM), and the AN/USM-470 Tailored Mini Vast (TMV) are test equipment used aboard aircraft carriers and at shore installations. The use of computerized ATE or automatic test system (ATS)

significantly reduces the space needed for special and manual support test equipment. As such computerized equipment, CASS will replace many different types of computerized ATE with one modern, cost-effective family of test equipment that increases repair capability and readiness. After ATE test benches from carriers and shore-based intermediate-level maintenance facilities are replaced, CASS will support a workload from the current and planned naval aviation inventory of aircraft to include the F/A-18 (all models), the EA-6B, the F-14 (all models), the H-60, the H-3, the E-2C, and the V-22.

### GENERAL DESCRIPTION

The CASS test station can test avionics systems whose technology encompasses frequency stimulus, frequency measurement, and digital functions. CASS capabilities include power conditioning, interface control, calibration, self-maintenance, instrumentation, and software to perform end-to-end tests, fault isolation tests, and alignment or adjustment of units under test (UUT). UUTs are interfaced to the test stations by test program sets (TPS), interface devices (ID), and accessories.

### CASS CONFIGURATIONS

Since one test station capable of meeting all needs would be too large, CASS is modular. CASS test station modules are grouped in distinct configurations that are based upon the needs of the weapons system or systems that the test station supports.

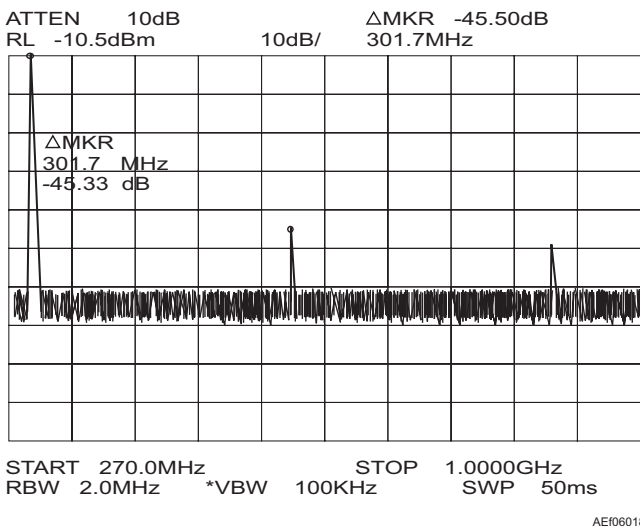

Figure 6-18.—Harmonic distortion of second harmonic measured in dB.

There are four standard configurations of Navy CASS for intermediate- and depot-level testing. The CASS hybrid station, shown in figure 6-20, is the common core for the other three bench configurations—radio frequency, communication/navigation/identification friend or foe (CNI), and electro-optics (EO). The following descriptions summarize these configurations:

- **Hybrid Station.** The hybrid station is the general-purpose station for testing electrical/electronic equipment as well as computers, instruments, and flight control systems. Furthermore, the hybrid station can be used for testing pneumatics, displays, and inertial navigation systems.
- **Radio Frequency Station.** In addition to the capabilities of the hybrid station, the RF station has the capability to test electronic countermeasures (ECM), electronic counter countermeasures (ECCM), electronic warfare (EW), fire control radar, navigation radar, tracking radar, surveillance radar, and radar altimeters.
- **Communication/Navigation/Identification Friend or Foe Station.** In addition to the

capabilities of the RF station, which includes the capabilities of the hybrid station, the CNI station can test communications, navigation, and spread spectrum systems.

- **Electro-Optics Station.** The CASS EO station has the basic test capabilities of the hybrid station plus the capability to test forward-looking infrared radar (FLIR), lasers/designators, laser range finders, and laser visual systems.

*Q6-49. What does the acronym CASS stand for?*

*Q6-50. List three benefits of CASS.*

*Q6-51. What device connects a unit under test (UUT) to the CASS bench?*

*Q6-52. List the standard configurations of CASS benches.*

*Q6-53. What is the purpose of the CASS hybrid test station?*

*Q6-54. The CASS electro-optics station has the test capabilities of the hybrid station along with capabilities to test what additional equipment?*



**Figure 6-20.—CASS hybrid station.**

## CHAPTER 6

# ANSWERS TO REVIEW QUESTIONS

A6-1. Calibration

A6-2. Work center 670

A6-3. The general rules for handling test equipment include:

1. Use test equipment properly and only for its designed purpose.
2. Select the proper range for the measured quantity.
3. Protect the equipment from physical harm that may result from dropping, falling, or other misuse.
4. Store test equipment in a clean, dry place with dust covers attached. (This reduces the chances of corrosion and water intrusion).
5. Use the test equipment instruction manual.

A6-4. Nonsinusoidal signals

A6-5. The frequency response of the meter being used

A6-6. Across the load or power source (in parallel with the circuit)

A6-7. Greater than  $1\Omega$

A6-8. Off

A6-9. In series with circuit being measured thus allowing all the circuit current to flow through the meter circuitry

A6-10. The closed position

A6-11. To measure the current leakage of the insulation by providing a high voltage to a component under test

A6-12. Capacitors, insulated cables, antennas, insulators, and high-resistance ground components

A6-13. A generator and an indicating meter

A6-14. About 0 ohms

A6-15. The equipment should be grounded or shorted

A6-16. The MJ10 generates voltage with a hand-driven generator and the BM12 uses a generator driven by six 1.5-Vdc batteries

A6-17. 46 GHz

A6-18. Period, ratio, time interval, time interval delay, interval average, and totalize

A6-19. The internal crystal oscillator (oven oscillator) or time base

A6-20. By keeping the counter connected to power

A6-21. The conventional counter and reciprocal counter

A6-22. The reciprocal type counter always makes period measurements of the input signal and then takes the reciprocal of that measurement if a frequency

*measurement is required whereas the conventional type counter measures the input signal by counting the number of cycles and dividing it by the time interval.*

*A6-23. 1.3 GHz*

*A6-24. Measurement of harmonically related signals*

*A6-25. The power meter*

*A6-26. Thermocouples, diodes, and thermistors*

*A6-27. For sensitivity as well as low-noise and drift characteristics*

*A6-28. 100 kHz to 110 GHz, depending on the model of sensor used*

*A6-29. To let a technician analyze electrical and electronic signals when the technician troubleshoots or aligns electrical and electronic equipment*

*A6-30. The X-, Y-, and Z-axes*

*A6-31. X-axis represents time, Y-axis represents amplitude, and the Z-axis represents the intensity or brightness of the signal*

*A6-32. An oscilloscope can provide the following items of information:*

- The time of a signal*
- The voltage of a signal*
- The frequency of a signal*
- How often a particular portion of a signal is occurring relative to other portions*
- If a malfunctioning component is distorting a signal*
- How much of a signal is made of noise*
- If noise is changing with time*
- How much the signal is made up of ac*
- How much the signal is made up of dc*

*A6-33. Analog and digital*

*A6-34. The display on the CRT becomes dim and very hard to see.*

*A6-35. Analog, digitizing, and digital phosphor*

*A6-36. The sample rate*

*A6-37. The scope can display electrical events that may happen only once.*

*A6-38. VOLT/DIV control*

*A6-39. Trigger level control*

*A6-40. Digitizing storage oscilloscope*

*A6-41. False. The signal should cover the screen vertically.*

*A6-42. True*

*A6-43. The X- and Y-axis*

*A6-44. X-axis represents amplitude, and Y-axis represents frequency*

A6-45. *The spectrum of modulated waves in the radio frequency range and microwave region*

A6-46. *To mix or translate a frequency*

A6-47. *The vertical plates of the CRT*

A6-48. *-119.9 dBm to + 30 dBm and 1 kHz to 22 GHz, respectively*

A6-49. *Consolidated Automated Support System*

A6-50. *Benefits of CASS include the following:*

- *Increases repair capabilities*
- *Increases material readiness*
- *Reduces the physical space required for electronic testing equipment*

A6-51. *A test program set (TPS), an interface device, or an accessory*

A6-52. *Standard configurations are the following:*

- *Hybrid*
- *Radio frequency (RF)*
- *Communication/navigation/identification friend or foe (CNI)*
- *Electro-optics (EO)*

A6-53. *To be a general-purpose test station for the testing of electrical and electronic equipment as well as computers, instruments, and flight control systems*

A6-54. *Forward-looking infrared radar (FLIR), lasers/designators, laser range finders, and laser visual systems*





## APPENDIX I

# GLOSSARY

- 2M**—Miniature/Microminiature.
- AESR**—Aeronautical equipment service record.
- AIMD**—Aircraft intermediate maintenance department.
- AMPERE**—The basic unit of electrical current.
- AMPLIFIER**—The device that provides amplification (the increase in current, voltage, or power of a signal) without appreciably altering the original signal.
- AMPLITUDE**—The size of a signal as measured from a reference line to a maximum value above or below the line. Generally used to describe voltage, current, or power.
- ANTENNA**—A conductor or set of conductors used to radiate RF energy into space or to collect RF energy from space or to do both.
- ASR**—Assembly service record.
- ATE**—Automatic test equipment.
- ATTENUATOR**—A network of resistors used to reduce voltage, current, or power delivered to a load.
- AXIS**—A straight line, either real or imaginary, passing through a body around which the body revolves.
- BANDWIDTH**—The difference between the highest usable frequency of a device (upper frequency limit) and the lowest usable frequency of the device (lower frequency limit) - measured at the half-power points.
- BATTERY**—A device for converting chemical energy into electrical energy.
- BLOCK DIAGRAM**—A diagram in which the major components of an equipment or a system are represented by squares, rectangles, or other geometric figures, and the normal order of progression of a signal or current flow is represented by lines.
- CAPACITOR**—An electrical device capable of storing electrical energy in an electrostatic field.
- CASS**—Consolidated Automated Support System.
- CATHODE-RAY TUBE (CRT)**—An electron tube that has an electron gun, a deflection system, and a screen. This tube is used to display visual electronic signals.
- CONDUCTOR**—(1) A material with a large number of free electrons. (2) A material that easily permits electric current to flow.
- CURRENT**—The movement of electrons past a reference point. The passage of electrons through a conductor. Measured in amperes.
- CYCLE**—(1) One complete positive and one complete negative alternation of a current or voltage. (2) A 360-degree rotation of a vector generating a sine wave.
- DIODE**—An electron tube containing two electrodes: a cathode and a plate. (2) A two element, solid-state device made of either germanium or silicon; it is primarily used as a switching device.
- DIRECT CURRENT (DC)**—An electric current that flows in one direction only.
- DOPPLER EFFECT**—(1) The apparent change in frequency or pitch when a sound source moves either toward or away from a listener. (2) In radar, the change in frequency of a received signal caused by the relative motion between the radar and the target.
- ECM**—Electronic countermeasures.
- EFFICIENCY**—The ratio of output-signal power compared to the total input power, generally expressed as a percentage.
- EHR**—Equipment history record.
- ELECTRON**—The elementary negative charge that revolves around the nucleus of an atom.
- ELECTRON SHELL**—A group of electrons that have a common energy level that forms part of the outer structure (shell) of an atom.
- ENERGY**—The ability or capacity to do work.
- ESD**—Electrostatic discharge.

- ESDS**—Electrostatic discharge sensitive.
- FIELD**—The electromagnet that furnishes the magnetic field that interacts with the armature in motors and generators.
- FLIR**—Forward Looking InfraRed system.
- FREQUENCY (f)**—(1) The number of complete cycles per second existing in any form of wave motion, such as the number of cycles per second of an alternating current. (2) The rate at which the vector that generates a sine wave rotates.
- GPETE**—General purpose electronic test equipment.
- HERTZ (Hz)**—A unit of frequency equal to one cycle per second.
- HETERODYNE**—To mix two alternating currents of different frequencies in the same circuit; they are alternately additive and subtractive, thus producing two beat frequencies, which are the sum of, and difference between, the two original frequencies.
- I-LEVEL**—Intermediate level.
- IMA**—Intermediate maintenance activity.
- IMPEDANCE**—The total opposition offered to the flow of an alternating current. It may consist of any combination of resistance, inductive reactance, and capacitive reactance. The symbol for impedance is Z.
- INDUCTANCE**—The property of a circuit that tends to oppose a change in the existing current flow. The symbol for inductance is L.
- INERTIA**—The physical tendency of a body in motion to remain in motion and a body at rest to remain at rest unless acted upon by an outside force (Newton's first law of motion).
- IPB**—Illustrated parts breakdown.
- JOULE**—A unit of energy or work. A joule of energy is liberated by 1 ampere flowing for 1 second through a resistance of 1 ohm.
- JUNCTION**—(1) The connection between two or more conductors. (2) The contact between two dissimilar metals or materials, as in a thermocouple.
- KINETIC ENERGY**—Energy that a body possesses by virtue of its motion.
- LOAD**—(1) A device through which an electric current flows and which changes electrical energy into another form. (2) Power consumed by a device or circuit in performing its function.
- MATTER**—Any physical entity that possesses mass.
- MICRO**—A prefix meaning one-millionth.
- MICROMETER**—A unit of length equal to  $10^{-6}$  meter. Formerly a micron.
- MICRON**—See **MICROMETER**.
- MIL**—The diameter of a conductor equal to 1/1000 (.001) inch.
- MILLI**—A prefix meaning one-thousandth.
- MILLIAMMETER**—An ammeter that measures current in thousandths of an ampere.
- MIM**—Maintenance instructions manual.
- MODULATION**—The process of impressing intelligence upon a transmission medium, such as radio waves.
- MODULE**—A circuit or portion of a circuit packaged as a removable unit. A separable unit in a packaging scheme displaying regularity of dimensions.
- MOTOR**—A machine that converts electrical energy to mechanical energy. It is activated by ac or dc voltage, depending on the design.
- MRC**—Maintenance Requirements Card.
- MULTIMETER**—A single meter combining the functions of an ammeter, a voltmeter, and an ohmmeter.
- NANOMETER**—A unit of length equal to  $10^{-9}$  meter. Formerly millimicron.
- NOISE**—(1) In reference to sound, an unwanted disturbance caused by spurious waves that originate from man-made or natural sources. (2) In radar, erratic or random deflection or intensity of the indicator sweep that tends to mask small echo signals.
- NUCLEUS**—The central part of an atom that is mainly made up of protons and neutrons. It is the part of the atom that has the most mass.
- NULL**—On a polar-coordinate graph, the area that represents minimum or 0 radiation.
- O-LEVEL**—Organizational level.
- OHM**—The unit of electrical resistance. That value of electrical resistance through which a constant

potential difference of 1 volt across the resistance will maintain a current flow of 1 ampere through the resistance.

**OMA**—Organizational maintenance activity.

**PHASE**—The angular relationship between two alternating currents or voltages when the voltage or current is plotted as a function of time. When the two are in phase, the angle is zero; both reach their peak simultaneously. When out of phase, one will lead or lag the other; that is, at the instant when one is at its peak, the other will not be at peak value and (depending on the phase angle) may differ in polarity as well as magnitude.

**PMIC**—Periodic maintenance information card.

**PMS**—Planned Maintenance System or periodic maintenance services.

**POTENTIAL**—The amount of charge held by a body as compared to another point or body. Usually measured in volts.

**POTENTIAL ENERGY**—Energy caused by the position of one body with respect to another body or to the relative parts of the same body.

**POWER**—The rate of doing work or the rate of expending energy. The unit of electrical power is the watt.

**PPE**—Personal protective equipment.

**PROTON**—A positively charged particle in the nucleus.

**PULSE**—Signal characterized by a steep rise from and decay toward an initial level.

**RADAR**—An acronym for **RA**dio **D**etecting **A**nd **R**anging.

**RADCOM**—Radar/communications.

**RADIAN**—In a circle, the angle included within an arc equal to the radius of the circle. A complete circle contains  $2\pi$  radians. One radian equals 57.3 degrees and 1 degree equals 0.01745 radian.

**RANGE**—The length of a straight line between a radar set and a target.

**RATIO**—The value obtained by dividing one number by another, indicating their relative proportions.

**REACTANCE**—The opposition offered to the flow of an alternating current by the inductance, capacitance, or both, in any circuit.

**RECTIFIER**—A device used to convert ac to pulsating dc.

**RESISTANCE**—(1) The opposition a device or material offers to the flow of current. The effect of resistance is to raise the temperature of the material or device carrying the current. (2) A circuit element designed to offer a predetermined resistance to current flow. A resistance of 1 ohm will allow a current of 1 ampere to flow through it when a potential of 1 volt is applied.

**RESONANT CAVITY**—A space, normally enclosed by an electrically conductive surface, in which oscillatory electromagnetic energy is stored, and whose resonant frequency is determined primarily by the geometry of the enclosure.

**RIGIDITY**—The tendency of the spin axis of a gyro wheel to remain in a fixed direction in space if no force is applied to it.

**SCC**—Sequence control card.

**SM&R**—Source, maintenance, and recoverability.

**SONAR**—Acronym for **SO**und **NA**avigation and **R**anging. Apparatus or technique of obtaining information regarding objects or events under water.

**SONIC**—Pertaining to sounds capable of being heard by the human ear.

**SOURCE**—(1) The object that produces the waves or disturbance. (2) The name given to the end of a two-wire transmission line that is connected to a source. (3) The device that furnishes the electrical energy used by a load.

**SRA**—Shop replaceable assembly.

**SRC**—Scheduled removal component.

**TORQUE**—A measure of how much load a machine can turn. This measurement is expressed either in ounce-inches for torque synchro systems or in pound-feet for heavy machinery.

**TPS**—Test program set.

**TRIGGER**—A short pulse, either positive or negative, that can be used to cause an electronic function to take place.

**UNIT**—(1) An assembly or any combination of parts, subassemblies, and assemblies mounted together. Normally capable of independent operation. (2) A single object or thing.

**VALENCE**—The measure of the extent to which an atom is able to combine directly with other atoms. It generally depends on the number and arrangement of the electrons in the outermost shell of the atom.

**VECTOR**—A line used to represent both direction and magnitude.

**VELOCITY**—The rate at which a disturbance travels through a medium.

**VOLT**—The unit of electromotive force or electrical pressure. One volt is the pressure required to send 1 ampere of current through a resistance of 1 ohm.

**VOLTAGE**—(1) The term used to signify electrical pressure. Voltage is a force that causes current to flow through an electrical conductor. (2) The

voltage of a circuit is the greatest effective difference of potential between any two conductors of the circuit.

**WATT**—The unit of electrical power that is the product of voltage and current.

**WAVE PROPAGATION**—The radiation, as from an antenna, of RF energy into space, or of sound energy into a conducting medium.

**WAVELENGTH**—The distance, usually expressed in meters, traveled by a wave during the time interval of one complete cycle. It is equal to the velocity divided by the frequency.

**WORK**—The product of force and motion.

**WRA**—Weapons replaceable assembly.

## APPENDIX II

### REFERENCE LIST

- 27 Multimeter*, service manual, Fluke Corporation, Everett, WA, 1998.
- 436A Power Meter*, service manual, Hewlett Packard Company, Palo Alto, CA, 1988.
- 2246 Mod A Portable Oscilloscope*, service manual, Tektronix, Inc., Beaverton, OR, 1988.
- 5334A/B Universal Counter*, service manual, Hewlett Packard Company, Palo Alto, CA.
- 8562A/B Portable Spectrum Analyzer*, installation manual, Hewlett Packard Company, Rohnert Park, CA, 1986.
- 8840A Digital Multimeter*, instruction manual, Fluke Corporation, Everett, WA, 1985.
- ABCs of DMMs*, Fluke Corporation, Everett, WA, 1999.
- Aviation Electrician's Mate 3&2*, NAVEDTRA 14009, Naval Education and Training Professional Development and Technology Center, Pensacola, FL, 1991.
- Aviation Electronics Technician 3*, NAVEDTRA 14028, Naval Education and Training Professional Development and Technology Center, Pensacola, FL, 1991.
- Aviation Electronics Technician 2*, NAVEDTRA 14029, Naval Education and Training Professional Development and Technology Center, Pensacola, FL, 1992.
- Cass Implementation Plan (CIP)*, Naval Air Warfare Center (NAWC) Aircraft Division, Lakehurst, NJ, 2000.
- Fundamentals of Physics*, John Wiley & Sons Inc., NY, 1974.
- Fundamentals of the Electronic Counters*, 200 electronic counter series, Agilent Technologies, Test and Measurements, Englewood, CO.
- Insulation and Continuity Testers*, MJ10 and BM12 meggers, AVO International, Dallas, TX.
- Mathematics, Part I*, NAVEDTRA 10069-D1, Naval Education and Training Professional Development and Technology Center, Pensacola, FL, 1985.
- Modern Physics*, Holt, Rinehart, and Winston, NY, 1976.
- The Naval Aviation Maintenance Program (NAMP)* OPNAVINST 4790.2, Office of the Chief of Naval Operations, Washington, DC, 1998.
- Navy Electricity and Electronics Training Series (NEETS), Module 16, *Introduction to Test Equipment*, NAVEDTRA 14188, Naval Education and Training Professional Development and Technology Center, Pensacola, FL, 1996.
- Physics for Technicians*, McGraw-Hill Book Company, NY, 1974.
- Spectrum Analysis Basics*, Agilent Technologies, Test and Measurements, Englewood, CO, 2001.

*Standard Maintenance Practices Miniature/Microminiature (2M) Electronic Assembly Repair*, NAVAIR 01-1A-23, Naval Air Systems Command, Washington, DC, 1999.

*XYZs of Oscilloscopes*, Tektronix, Inc., Beaverton, OR, 1986.

## APPENDIX III

# SQUARES, CUBES, SQUARE ROOTS, CUBE ROOTS, LOGARITHMS, AND RECIPROCAL OF NUMBERS

No.	Square	Cube	Square Root	Cube Root	Log.	1000 x Recip.	No. = Dia.	
							Circum.	Area
1	1	1	1.0000	1.0000	0.00000	1000.000	3.142	0.7854
2	4	8	1.4142	1.2599	0.30103	500.000	6.283	3.1416
3	9	27	1.7321	1.4422	0.47712	333.333	9.425	7.0686
4	16	64	2.0000	1.5874	0.60206	250.000	12.566	12.5664
5	25	125	2.2361	1.7100	0.69897	200.000	15.708	19.6350
6	36	216	2.4495	1.8171	0.77815	166.667	18.850	28.2743
7	49	343	2.6458	1.9129	0.84510	142.857	21.991	38.4845
8	64	512	2.8284	2.0000	0.90308	125.000	25.133	50.2655
9	81	729	3.0000	2.0801	0.95424	111.111	28.274	63.6173
10	100	1000	3.1623	2.1544	1.00000	100.000	31.416	78.5398
11	121	1331	3.3166	2.2240	1.04139	90.9091	34.558	95.0332
12	144	1728	3.4641	2.2894	1.07918	83.3333	37.699	113.097
13	169	2197	3.6056	2.3513	1.11394	76.9231	40.841	132.732
14	196	2744	3.7417	2.4101	1.14613	71.4286	43.982	153.938
15	225	3375	3.8730	2.4662	1.17609	66.6667	47.124	176.715
16	256	4096	4.0000	2.5198	1.20412	62.5000	50.265	201.062
17	289	4913	4.1231	2.5713	1.23045	58.8235	53.407	226.980
18	324	5832	4.2426	2.6207	1.25527	55.5556	56.549	254.469
19	361	6859	4.3589	2.6684	1.27875	52.6316	59.690	283.529
20	400	8000	4.4721	2.7144	1.30103	50.0000	62.832	314.159
21	441	9261	4.5826	2.7589	1.32222	47.6190	65.973	346.361
22	484	10648	4.6904	2.8020	1.34242	45.4545	69.115	380.133
23	529	12167	4.7958	2.8439	1.36173	43.4783	72.257	415.476
24	576	13824	4.8990	2.8845	1.38021	41.6667	75.398	452.389
25	625	15625	5.0000	2.9240	1.39794	40.0000	78.540	490.874
26	676	17576	5.0990	2.9625	1.41497	38.4615	81.681	530.929
27	729	19683	5.1962	3.0000	1.43136	37.0370	84.823	572.555
28	784	21952	5.2915	3.0366	1.44716	35.7143	87.965	615.752
29	841	24389	5.3852	3.0723	1.46240	34.4828	91.106	660.520
30	900	27000	5.4772	3.1072	1.47712	33.3333	94.248	706.858
31	961	29791	5.5678	3.1414	1.49136	32.2581	97.389	754.768
32	1024	32768	5.6569	3.1748	1.50515	31.2500	100.531	804.248
33	1089	35937	5.7446	3.2075	1.51851	30.3030	103.673	855.299
34	1156	39304	5.8310	3.2396	1.53148	29.4118	106.814	907.920
35	1225	42875	5.9161	3.2711	1.54407	28.5714	109.956	962.113
36	1296	46656	6.0000	3.3019	1.55630	27.7778	113.097	1017.88
37	1369	50653	6.0828	3.3322	1.56820	27.0270	116.239	1075.21
38	1444	54872	6.1644	3.3620	1.57978	26.3158	119.381	1134.11
39	1521	59319	6.2450	3.3912	1.59106	25.6410	122.522	1194.59
40	1600	64000	6.3246	3.4200	1.60206	25.0000	125.66	1256.64
41	1681	68921	6.4031	3.4482	1.61278	24.3902	128.81	1320.25
42	1764	74088	6.4807	3.4760	1.62325	23.8095	131.95	1385.44
43	1849	79507	6.5574	3.5034	1.63347	23.2558	135.09	1452.20
44	1936	85184	6.6332	3.5303	1.64345	22.7273	138.23	1520.53

No.	Square	Cube	Square Root	Cube Root	Log.	1000 x Recip.	No. = Dia.	
							Circum.	Area
45	2025	91125	6.7082	3.5569	1.65321	22.2222	141.37	1590.43
46	2116	97336	6.7823	3.5830	1.66276	21.7391	144.51	1661.90
47	2209	103823	6.8557	3.6088	1.67210	21.2766	147.65	1734.94
48	2304	110592	6.9282	3.6342	1.68124	20.8333	150.80	1809.56
49	2401	117649	7.0000	3.6593	1.69020	20.4082	153.94	1885.74
50	2500	125000	7.0711	3.6840	1.69897	20.0000	157.08	1963.50
51	2601	132651	7.1414	3.7084	1.70757	19.6078	160.22	2042.82
52	2704	140608	7.2111	3.7325	1.71600	19.2308	163.36	2123.72
53	2809	148877	7.2801	3.7563	1.72428	18.8679	166.50	2206.18
54	2916	157464	7.3485	3.7798	1.73239	18.5185	169.65	2290.22
55	3025	166375	7.4162	3.8030	1.74036	18.1818	172.79	2375.83
56	3136	175616	7.4833	3.8259	1.74819	17.8571	175.93	2463.01
57	3249	185193	7.5498	3.8485	1.75587	17.5439	179.07	2551.76
58	3364	195112	7.6158	3.8709	1.76343	17.2414	182.21	2642.08
59	3481	205379	7.6811	3.8930	1.77085	16.9492	185.35	2733.97
60	3600	216000	7.7460	3.9149	1.77815	16.6667	188.50	2827.43
61	3721	226981	7.8102	3.9365	1.78533	16.3934	191.64	2922.47
62	3844	238328	7.8740	3.9579	1.79239	16.1290	194.78	3019.07
63	3969	250047	7.9373	3.9791	1.79934	15.8730	197.92	3117.25
64	4096	262144	8.0000	4.0000	1.80618	15.6250	201.06	3216.99
65	4225	274625	8.0623	4.0207	1.81291	15.3846	204.20	3318.31
66	4356	287496	8.1240	4.0412	1.81954	15.1515	207.35	3421.19
67	4489	300763	8.1854	4.0615	1.82607	14.9254	210.49	3525.65
68	4624	314432	8.2462	4.0817	1.83251	14.7059	213.63	3631.68
69	4761	328509	8.3066	4.1016	1.83885	14.4928	216.77	3739.28
70	4900	343000	8.3666	4.1213	1.84510	14.2857	219.91	3848.45
71	5041	357911	8.4261	4.1408	1.85126	14.0845	223.05	3959.19
72	5184	373248	8.4853	4.1602	1.85733	13.8889	226.19	4071.50
73	5329	389017	8.5440	4.1793	1.86332	13.6986	229.34	4185.39
74	5476	405224	8.6023	4.1983	1.86923	13.5135	232.48	4300.84
75	5625	421875	8.6603	4.2172	1.87506	13.3333	235.62	4417.86
76	5776	438976	8.7178	4.2358	1.88081	13.1579	238.76	4536.46
77	5929	456533	8.7750	4.2543	1.88649	12.9870	241.90	4656.63
78	6084	474552	8.8318	4.2727	1.89209	12.8205	245.04	4778.36
79	6241	493039	8.8882	4.2908	1.89763	12.6582	248.19	4901.67
80	6400	512000	8.9443	4.3089	1.90309	12.5000	251.33	5026.55
81	6561	531441	9.0000	4.3267	1.90849	12.3457	254.47	5153.00
82	6724	551368	9.0554	4.3445	1.91381	12.1951	257.61	5281.02
83	6889	571787	9.1104	4.3621	1.91908	12.0482	260.75	5410.61
84	7056	592704	9.1652	4.3795	1.92428	11.9048	263.89	5541.77
85	7225	614125	9.2195	4.3968	1.92942	11.7647	267.04	5674.50
86	7396	636056	9.2736	4.4140	1.93450	11.6279	270.18	5808.80
87	7569	658503	9.3274	4.4310	1.93952	11.4943	273.32	5944.68
88	7744	681472	9.3808	4.4480	1.94448	11.3636	276.46	6082.12
89	7921	704969	9.4340	4.4647	1.94939	11.2360	279.60	6221.14



No.	Square	Cube	Square Root	Cube Root	Log.	1000 x Recip.	No. = Dia.	
							Circum.	Area
90	8100	729000	9.4868	4.4814	1.95424	11.1111	282.74	6361.73
91	8281	753571	9.5394	4.4979	1.95904	10.9890	285.88	6503.88
92	8464	778688	9.5917	4.5144	1.96379	10.8696	289.03	6647.61
93	8649	804357	9.6437	4.5307	1.96848	10.7527	292.17	6792.91
94	8836	830584	9.6954	4.5468	1.97313	10.6383	295.31	6939.78
95	9025	857375	9.7468	4.5629	1.97772	10.5263	298.45	7088.22
96	9216	884736	9.7980	4.5789	1.98227	10.4167	301.59	7238.23
97	9409	912673	9.8489	4.5947	1.98677	10.3093	304.73	7389.81
98	9604	941192	9.8995	4.6104	1.99123	10.2041	307.88	7542.96
99	9801	970299	9.9499	4.6261	1.99564	10.1010	311.02	7697.69
100	10000	1000000	10.0000	4.6416	2.00000	10.00000	314.16	7853.98
101	10201	1030301	10.0499	4.6570	2.00432	9.90099	317.30	8011.85
102	10404	1061208	10.0995	4.6723	2.00860	9.80392	320.44	8171.28
103	10609	1092727	10.1489	4.6875	2.01284	9.70874	323.58	8332.29
104	10816	1124864	10.1980	4.7027	2.01703	9.61538	326.73	8494.87
105	11025	1157625	10.2470	4.7177	2.02119	9.52381	329.87	8659.01
106	11236	1191016	10.2956	4.7326	2.02531	9.43396	333.01	8824.73
107	11449	1225043	10.3441	4.7475	2.02938	9.34579	336.15	8992.02
108	11664	1259712	10.3923	4.7622	2.03342	9.25926	339.29	9160.88
109	11881	1295029	10.4403	4.7769	2.03743	9.17431	342.43	9331.32
110	12100	1331000	10.4881	4.7914	2.04139	9.09091	345.58	9503.32
111	12321	1367631	10.5357	4.8059	2.04532	9.00901	348.72	9676.89
112	12544	1404928	10.5830	4.8203	2.04922	8.92857	351.86	9852.03
113	12769	1442897	10.6301	4.8346	2.05308	8.84956	355.00	10028.7
114	12996	1481544	10.6771	4.8488	2.05690	8.77193	358.14	10207.0
115	13225	1520875	10.7238	4.8629	2.06070	8.69565	361.28	10386.9
116	13456	1560896	10.7703	4.8770	2.06446	8.62069	364.42	10568.3
117	13689	1601613	10.8167	4.8910	2.06819	8.54701	367.57	10751.3
118	13924	1643032	10.8628	4.9049	2.07188	8.47458	370.71	10935.9
119	14161	1685159	10.9087	4.9187	2.07555	8.40336	373.85	11122.0
120	14400	1728000	10.9545	4.9324	2.07918	8.33333	376.99	11309.7
121	14641	1771561	11.0000	4.9461	2.08279	8.26446	380.13	11499.0
122	14884	1815848	11.0454	4.9597	2.08636	8.19672	383.27	11689.9
123	15129	1860867	11.0905	4.9732	2.08991	8.13008	386.42	11882.3
124	15376	1906624	11.1355	4.9866	2.09342	8.06452	389.56	12076.3
125	15625	1953125	11.1803	5.0000	2.09691	8.00000	392.70	12271.8
126	15876	2000376	11.2250	5.0133	2.10037	7.93651	395.84	12469.0
127	16129	2048383	11.2694	5.0265	2.10380	7.87402	398.98	12667.7
128	16384	2097152	11.3137	5.0397	2.10721	7.81250	402.12	12868.0
129	16641	2146689	11.3578	5.0528	2.11059	7.75194	405.27	13069.8
130	16900	2197000	11.4018	5.0653	2.11394	7.69231	408.41	13273.2
131	17161	2248091	11.4455	5.0788	2.11727	7.63359	411.55	13478.2
132	17424	2299968	11.4891	5.0916	2.12057	7.57576	414.69	13684.8
133	17689	2352637	11.5326	5.1045	2.12385	7.51880	417.83	13892.9
134	17956	2406104	11.5758	5.1172	2.12710	7.46269	420.97	14102.6



# APPENDIX IV

## NATURAL SINES, COSINES, AND TANGENTS OF ANGLES FROM 0° to 90°

0°-14.9°

Degs.	Function	0.0°	0.1°	0.2°	0.3°	0.4°	0.5°	0.6°	0.7°	0.8°	0.9°
0	sin	0.0000	0.0017	0.0035	0.0052	0.0070	0.0087	0.0105	0.0122	0.0140	0.0157
	cos	1.0000	0.9998	0.9996	0.9993	0.9990	0.9987	0.9984	0.9981	0.9978	0.9975
	tan	0.0000	0.0017	0.0035	0.0052	0.0070	0.0087	0.0105	0.0122	0.0140	0.0157
1	sin	0.0175	0.0192	0.0209	0.0227	0.0244	0.0262	0.0279	0.0297	0.0314	0.0332
	cos	0.9998	0.9998	0.9998	0.9997	0.9997	0.9997	0.9996	0.9996	0.9995	0.9995
	tan	0.0175	0.0192	0.0209	0.0227	0.0244	0.0262	0.0279	0.0297	0.0314	0.0332
2	sin	0.0349	0.0366	0.0384	0.0401	0.0419	0.0436	0.0454	0.0471	0.0488	0.0506
	cos	0.9994	0.9993	0.9993	0.9992	0.9991	0.9990	0.9990	0.9989	0.9988	0.9987
	tan	0.0349	0.0367	0.0384	0.0402	0.0419	0.0437	0.0454	0.0472	0.0489	0.0507
3	sin	0.0523	0.0541	0.0558	0.0576	0.0593	0.0610	0.0628	0.0645	0.0663	0.0680
	cos	0.9986	0.9985	0.9984	0.9983	0.9982	0.9981	0.9980	0.9979	0.9978	0.9977
	tan	0.0524	0.0542	0.0559	0.0577	0.0594	0.0612	0.0629	0.0647	0.0664	0.0682
4	sin	0.0698	0.0715	0.0732	0.0750	0.0767	0.0785	0.0802	0.0819	0.0837	0.0854
	cos	0.9976	0.9974	0.9973	0.9972	0.9971	0.9969	0.9968	0.9966	0.9965	0.9963
	tan	0.0699	0.0717	0.0734	0.0752	0.0769	0.0787	0.0805	0.0822	0.0840	0.0857
5	sin	0.0872	0.0889	0.0906	0.0924	0.0941	0.0958	0.0976	0.0993	0.1011	0.1028
	cos	0.9962	0.9960	0.9959	0.9957	0.9956	0.9954	0.9952	0.9951	0.9949	0.9947
	tan	0.0875	0.0892	0.0910	0.0928	0.0945	0.0963	0.0981	0.0998	0.1016	0.1033
6	sin	0.1045	0.1063	0.1080	0.1097	0.1115	0.1132	0.1149	0.1167	0.1184	0.1201
	cos	0.9945	0.9943	0.9942	0.9940	0.9938	0.9936	0.9934	0.9932	0.9930	0.9928
	tan	0.1051	0.1069	0.1086	0.1104	0.1122	0.1139	0.1157	0.1175	0.1192	0.1210
7	sin	0.1219	0.1236	0.1253	0.1271	0.1288	0.1305	0.1323	0.1340	0.1357	0.1374
	cos	0.9925	0.9923	0.9921	0.9919	0.9917	0.9914	0.9912	0.9910	0.9907	0.9905
	tan	0.1228	0.1246	0.1263	0.1281	0.1299	0.1317	0.1334	0.1352	0.1370	0.1388
8	sin	0.1392	0.1409	0.1426	0.1444	0.1461	0.1478	0.1495	0.1513	0.1530	0.1547
	cos	0.9903	0.9900	0.9898	0.9896	0.9893	0.9890	0.9888	0.9885	0.9882	0.9880
	tan	0.1405	0.1423	0.1441	0.1459	0.1477	0.1495	0.1512	0.1530	0.1548	0.1566
9	sin	0.1564	0.1582	0.1599	0.1616	0.1633	0.1650	0.1668	0.1685	0.1702	0.1719
	cos	0.9877	0.9874	0.9871	0.9869	0.9866	0.9863	0.9860	0.9857	0.9854	0.9851
	tan	0.1584	0.1602	0.1620	0.1638	0.1656	0.1673	0.1691	0.1709	0.1727	0.1745
10	sin	0.1736	0.1754	0.1771	0.1788	0.1806	0.1822	0.1840	0.1857	0.1874	0.1891
	cos	0.9848	0.9845	0.9842	0.9839	0.9836	0.9833	0.9829	0.9826	0.9823	0.9820
	tan	0.1763	0.1781	0.1799	0.1817	0.1835	0.1853	0.1871	0.1890	0.1908	0.1926
11	sin	0.1908	0.1925	0.1942	0.1959	0.1977	0.1994	0.2011	0.2028	0.2045	0.2062
	cos	0.9816	0.9813	0.9810	0.9806	0.9803	0.9799	0.9796	0.9792	0.9789	0.9785
	tan	0.1944	0.1962	0.1980	0.1998	0.2016	0.2035	0.2053	0.2071	0.2089	0.2107
12	sin	0.2079	0.2096	0.2113	0.2130	0.2147	0.2164	0.2181	0.2198	0.2215	0.2232
	cos	0.9781	0.9778	0.9774	0.9770	0.9767	0.9763	0.9759	0.9755	0.9751	0.9748
	tan	0.2126	0.2144	0.2162	0.2180	0.2199	0.2217	0.2235	0.2254	0.2272	0.2290
13	sin	0.2250	0.2267	0.2284	0.2300	0.2317	0.2334	0.2351	0.2368	0.2385	0.2402
	cos	0.9744	0.9740	0.9736	0.9732	0.9728	0.9724	0.9720	0.9715	0.9711	0.9707
	tan	0.2309	0.2327	0.2345	0.2364	0.2382	0.2401	0.2419	0.2438	0.2456	0.2475
14	sin	0.2419	0.2436	0.2453	0.2470	0.2487	0.2504	0.2521	0.2538	0.2554	0.2571
	cos	0.9703	0.9699	0.9694	0.9690	0.9686	0.9681	0.9677	0.9673	0.9668	0.9664
	tan	0.2493	0.2512	0.2530	0.2549	0.2568	0.2586	0.2605	0.2623	0.2642	0.2661
Degs.	Function	0'	6'	12'	18'	24'	30'	36'	42'	48'	54'

15°-29.9°

Degr.	Function	0.0°	0.1°	0.2°	0.3°	0.4°	0.5°	0.6°	0.7°	0.8°	0.9°
15	sin	0.2588	0.2606	0.2622	0.2639	0.2656	0.2672	0.2689	0.2706	0.2723	0.2740
	cos	0.9659	0.9655	0.9650	0.9646	0.9641	0.9636	0.9632	0.9627	0.9622	0.9617
	tan	0.2679	0.2698	0.2717	0.2736	0.2754	0.2773	0.2792	0.2811	0.2830	0.2849
16	sin	0.2756	0.2773	0.2790	0.2807	0.2823	0.2840	0.2857	0.2874	0.2890	0.2907
	cos	0.9613	0.9608	0.9603	0.9598	0.9593	0.9588	0.9583	0.9578	0.9573	0.9568
	tan	0.2867	0.2886	0.2906	0.2924	0.2943	0.2962	0.2981	0.3000	0.3019	0.3038
17	sin	0.2924	0.2940	0.2957	0.2974	0.2990	0.3007	0.3024	0.3040	0.3057	0.3074
	cos	0.9563	0.9558	0.9553	0.9548	0.9543	0.9537	0.9532	0.9527	0.9521	0.9516
	tan	0.3067	0.3076	0.3096	0.3115	0.3134	0.3153	0.3172	0.3191	0.3211	0.3230
18	sin	0.3090	0.3107	0.3123	0.3140	0.3156	0.3173	0.3190	0.3206	0.3223	0.3239
	cos	0.9511	0.9505	0.9500	0.9494	0.9489	0.9483	0.9478	0.9472	0.9466	0.9461
	tan	0.3249	0.3269	0.3288	0.3307	0.3327	0.3346	0.3365	0.3385	0.3404	0.3424
19	sin	0.3256	0.3272	0.3289	0.3305	0.3322	0.3338	0.3355	0.3371	0.3387	0.3404
	cos	0.9455	0.9449	0.9444	0.9438	0.9432	0.9426	0.9421	0.9415	0.9409	0.9403
	tan	0.3443	0.3463	0.3482	0.3502	0.3522	0.3541	0.3561	0.3581	0.3600	0.3620
20	sin	0.3420	0.3437	0.3453	0.3469	0.3486	0.3502	0.3518	0.3535	0.3551	0.3567
	cos	0.9397	0.9391	0.9385	0.9379	0.9373	0.9367	0.9361	0.9354	0.9348	0.9342
	tan	0.3640	0.3659	0.3679	0.3699	0.3719	0.3739	0.3759	0.3779	0.3799	0.3819
21	sin	0.3584	0.3600	0.3616	0.3633	0.3649	0.3665	0.3681	0.3697	0.3714	0.3730
	cos	0.9336	0.9330	0.9323	0.9317	0.9311	0.9304	0.9298	0.9291	0.9285	0.9278
	tan	0.3839	0.3859	0.3879	0.3899	0.3919	0.3939	0.3959	0.3979	0.4000	0.4020
22	sin	0.3746	0.3762	0.3778	0.3795	0.3811	0.3827	0.3843	0.3860	0.3875	0.3891
	cos	0.9272	0.9265	0.9259	0.9252	0.9245	0.9239	0.9232	0.9225	0.9219	0.9212
	tan	0.4040	0.4061	0.4081	0.4101	0.4122	0.4142	0.4163	0.4183	0.4204	0.4224
23	sin	0.3907	0.3923	0.3939	0.3955	0.3971	0.3987	0.4003	0.4019	0.4035	0.4051
	cos	0.9206	0.9198	0.9191	0.9184	0.9178	0.9171	0.9164	0.9157	0.9150	0.9143
	tan	0.4245	0.4265	0.4286	0.4307	0.4327	0.4348	0.4369	0.4390	0.4411	0.4431
24	sin	0.4067	0.4083	0.4099	0.4115	0.4131	0.4147	0.4163	0.4179	0.4196	0.4212
	cos	0.9135	0.9128	0.9121	0.9114	0.9107	0.9100	0.9092	0.9085	0.9078	0.9070
	tan	0.4452	0.4473	0.4494	0.4515	0.4536	0.4557	0.4578	0.4599	0.4621	0.4642
25	sin	0.4226	0.4242	0.4258	0.4274	0.4289	0.4305	0.4321	0.4337	0.4353	0.4369
	cos	0.9063	0.9056	0.9048	0.9041	0.9033	0.9026	0.9018	0.9011	0.9003	0.8996
	tan	0.4663	0.4684	0.4706	0.4727	0.4748	0.4770	0.4791	0.4813	0.4834	0.4856
26	sin	0.4334	0.4350	0.4365	0.4381	0.4396	0.4412	0.4428	0.4443	0.4459	0.4474
	cos	0.8988	0.8980	0.8973	0.8965	0.8957	0.8949	0.8942	0.8934	0.8926	0.8918
	tan	0.4877	0.4899	0.4921	0.4942	0.4964	0.4986	0.5008	0.5030	0.5051	0.5072
27	sin	0.4540	0.4555	0.4571	0.4586	0.4602	0.4617	0.4632	0.4648	0.4664	0.4679
	cos	0.8910	0.8902	0.8894	0.8886	0.8878	0.8870	0.8862	0.8854	0.8846	0.8838
	tan	0.5098	0.5117	0.5139	0.5161	0.5184	0.5206	0.5228	0.5250	0.5272	0.5294
28	sin	0.4666	0.4710	0.4726	0.4741	0.4756	0.4772	0.4787	0.4803	0.4818	0.4833
	cos	0.8829	0.8821	0.8813	0.8805	0.8796	0.8788	0.8780	0.8771	0.8763	0.8755
	tan	0.5317	0.5340	0.5362	0.5384	0.5407	0.5430	0.5452	0.5475	0.5498	0.5520
29	sin	0.4845	0.4863	0.4879	0.4894	0.4909	0.4924	0.4939	0.4955	0.4970	0.4985
	cos	0.8746	0.8738	0.8729	0.8721	0.8712	0.8704	0.8695	0.8686	0.8678	0.8669
	tan	0.5643	0.5566	0.5589	0.5612	0.5635	0.5658	0.5681	0.5704	0.5727	0.5750
Degr.	Function	0'	6'	12'	18'	24'	30'	36'	42'	48'	54'

30°-44.9°

Degr.	Function	0.0°	0.1°	0.2°	0.3°	0.4°	0.5°	0.6°	0.7°	0.8°	0.9°
30	sin	0.5000	0.5015	0.5030	0.5045	0.5060	0.5075	0.5090	0.5105	0.5120	0.5135
	cos	0.8660	0.8632	0.8603	0.8574	0.8545	0.8516	0.8487	0.8458	0.8429	0.8400
	tan	0.5774	0.5797	0.5820	0.5844	0.5867	0.5890	0.5914	0.5938	0.5961	0.5985
31	sin	0.5150	0.5165	0.5180	0.5195	0.5210	0.5225	0.5240	0.5255	0.5270	0.5284
	cos	0.8572	0.8563	0.8554	0.8545	0.8536	0.8526	0.8517	0.8508	0.8499	0.8490
	tan	0.6009	0.6032	0.6056	0.6080	0.6104	0.6128	0.6152	0.6176	0.6200	0.6224
32	sin	0.5299	0.5314	0.5329	0.5344	0.5358	0.5373	0.5388	0.5402	0.5417	0.5432
	cos	0.8440	0.8471	0.8462	0.8453	0.8443	0.8434	0.8425	0.8415	0.8406	0.8396
	tan	0.6249	0.6273	0.6297	0.6322	0.6346	0.6371	0.6395	0.6420	0.6445	0.6469
33	sin	0.5446	0.5461	0.5476	0.5490	0.5505	0.5519	0.5534	0.5548	0.5563	0.5577
	cos	0.8387	0.8377	0.8368	0.8358	0.8348	0.8339	0.8329	0.8320	0.8310	0.8300
	tan	0.6494	0.6519	0.6544	0.6569	0.6594	0.6619	0.6644	0.6669	0.6694	0.6720
34	sin	0.5592	0.5606	0.5621	0.5635	0.5650	0.5664	0.5678	0.5693	0.5707	0.5721
	cos	0.8290	0.8281	0.8271	0.8261	0.8251	0.8241	0.8231	0.8221	0.8211	0.8202
	tan	0.6745	0.6771	0.6796	0.6822	0.6847	0.6873	0.6899	0.6924	0.6950	0.6976
35	sin	0.5736	0.5750	0.5764	0.5779	0.5793	0.5807	0.5821	0.5835	0.5850	0.5864
	cos	0.8182	0.8181	0.8171	0.8161	0.8151	0.8141	0.8131	0.8121	0.8111	0.8100
	tan	0.7002	0.7028	0.7054	0.7080	0.7107	0.7133	0.7159	0.7186	0.7212	0.7239
36	sin	0.5878	0.5892	0.5906	0.5920	0.5934	0.5948	0.5962	0.5976	0.5990	0.6004
	cos	0.8090	0.8080	0.8070	0.8059	0.8049	0.8039	0.8028	0.8018	0.8007	0.7997
	tan	0.7265	0.7292	0.7319	0.7346	0.7373	0.7400	0.7427	0.7454	0.7481	0.7508
37	sin	0.6018	0.6032	0.6046	0.6060	0.6074	0.6088	0.6101	0.6115	0.6129	0.6143
	cos	0.7986	0.7976	0.7965	0.7955	0.7944	0.7934	0.7923	0.7912	0.7902	0.7891
	tan	0.7536	0.7563	0.7590	0.7618	0.7646	0.7673	0.7701	0.7729	0.7757	0.7785
38	sin	0.6157	0.6170	0.6184	0.6198	0.6211	0.6225	0.6239	0.6252	0.6266	0.6280
	cos	0.7890	0.7889	0.7889	0.7888	0.7887	0.7886	0.7885	0.7884	0.7883	0.7882
	tan	0.7813	0.7841	0.7869	0.7898	0.7926	0.7954	0.7983	0.8012	0.8040	0.8069
39	sin	0.6293	0.6307	0.6320	0.6334	0.6347	0.6361	0.6374	0.6388	0.6401	0.6414
	cos	0.7771	0.7760	0.7749	0.7738	0.7727	0.7716	0.7705	0.7694	0.7683	0.7672
	tan	0.8098	0.8127	0.8156	0.8185	0.8214	0.8243	0.8273	0.8302	0.8332	0.8361
40	sin	0.6428	0.6441	0.6455	0.6468	0.6481	0.6494	0.6508	0.6521	0.6534	0.6547
	cos	0.7660	0.7649	0.7638	0.7627	0.7615	0.7604	0.7593	0.7581	0.7570	0.7559
	tan	0.8391	0.8421	0.8451	0.8481	0.8511	0.8541	0.8571	0.8601	0.8632	0.8662
41	sin	0.6561	0.6574	0.6587	0.6600	0.6613	0.6626	0.6639	0.6652	0.6665	0.6678
	cos	0.7547	0.7536	0.7524	0.7513	0.7501	0.7490	0.7478	0.7466	0.7455	0.7443
	tan	0.8693	0.8724	0.8754	0.8785	0.8816	0.8847	0.8878	0.8910	0.8941	0.8972
42	sin	0.6691	0.6704	0.6717	0.6730	0.6743	0.6756	0.6769	0.6782	0.6794	0.6807
	cos	0.7431	0.7420	0.7408	0.7396	0.7385	0.7373	0.7361	0.7349	0.7337	0.7325
	tan	0.9004	0.9036	0.9067	0.9099	0.9131	0.9163	0.9195	0.9228	0.9260	0.9293
43	sin	0.6820	0.6833	0.6845	0.6858	0.6871	0.6884	0.6896	0.6909	0.6921	0.6934
	cos	0.7314	0.7302	0.7290	0.7278	0.7266	0.7254	0.7242	0.7230	0.7218	0.7206
	tan	0.9325	0.9358	0.9391	0.9424	0.9457	0.9490	0.9523	0.9556	0.9590	0.9623
44	sin	0.6947	0.6959	0.6972	0.6984	0.6997	0.7009	0.7022	0.7034	0.7046	0.7059
	cos	0.7183	0.7181	0.7169	0.7157	0.7145	0.7133	0.7120	0.7108	0.7096	0.7083
	tan	0.9657	0.9691	0.9725	0.9759	0.9793	0.9827	0.9861	0.9896	0.9930	0.9965
Degr.	Function	0'	6'	12'	18'	24'	30'	36'	42'	48'	54'

45°-59.9°

Degr.	Function	0.0°	0.1°	0.2°	0.3°	0.4°	0.5°	0.6°	0.7°	0.8°	0.9°
45	sin	0.7071	0.7063	0.7056	0.7102	0.7120	0.7133	0.7145	0.7157	0.7169	0.7181
	cos	0.7071	0.7069	0.7066	0.7034	0.7022	0.7009	0.6997	0.6984	0.6972	0.6959
	tan	1.0000	1.0035	1.0070	1.0106	1.0141	1.0176	1.0212	1.0247	1.0283	1.0319
46	sin	0.7193	0.7206	0.7218	0.7230	0.7242	0.7254	0.7266	0.7278	0.7290	0.7302
	cos	0.6947	0.6934	0.6921	0.6909	0.6896	0.6884	0.6871	0.6858	0.6845	0.6833
	tan	1.0355	1.0392	1.0428	1.0464	1.0501	1.0538	1.0575	1.0612	1.0649	1.0686
47	sin	0.7314	0.7325	0.7337	0.7349	0.7361	0.7373	0.7385	0.7396	0.7408	0.7420
	cos	0.6820	0.6807	0.6794	0.6782	0.6769	0.6756	0.6743	0.6730	0.6717	0.6704
	tan	1.0724	1.0761	1.0799	1.0837	1.0875	1.0913	1.0951	1.0990	1.1028	1.1067
48	sin	0.7431	0.7443	0.7455	0.7466	0.7478	0.7490	0.7501	0.7513	0.7524	0.7536
	cos	0.6691	0.6678	0.6665	0.6653	0.6639	0.6626	0.6613	0.6600	0.6587	0.6574
	tan	1.1106	1.1145	1.1184	1.1224	1.1263	1.1303	1.1343	1.1383	1.1423	1.1463
49	sin	0.7547	0.7559	0.7570	0.7581	0.7593	0.7604	0.7615	0.7627	0.7638	0.7649
	cos	0.6561	0.6547	0.6534	0.6521	0.6508	0.6494	0.6481	0.6468	0.6455	0.6441
	tan	1.1504	1.1544	1.1583	1.1623	1.1667	1.1708	1.1750	1.1792	1.1833	1.1875
50	sin	0.7660	0.7672	0.7683	0.7694	0.7705	0.7716	0.7727	0.7738	0.7749	0.7760
	cos	0.6423	0.6414	0.6401	0.6389	0.6374	0.6361	0.6347	0.6334	0.6320	0.6307
	tan	1.1918	1.1960	1.2002	1.2045	1.2088	1.2131	1.2174	1.2218	1.2261	1.2306
51	sin	0.7771	0.7782	0.7793	0.7804	0.7815	0.7826	0.7837	0.7848	0.7859	0.7869
	cos	0.6293	0.6280	0.6266	0.6252	0.6239	0.6226	0.6211	0.6198	0.6184	0.6170
	tan	1.2349	1.2393	1.2437	1.2482	1.2527	1.2572	1.2617	1.2662	1.2708	1.2753
52	sin	0.7880	0.7891	0.7902	0.7912	0.7923	0.7934	0.7944	0.7955	0.7965	0.7976
	cos	0.6157	0.6143	0.6129	0.6115	0.6101	0.6088	0.6074	0.6060	0.6046	0.6032
	tan	1.2799	1.2846	1.2892	1.2938	1.2985	1.3032	1.3079	1.3127	1.3175	1.3222
53	sin	0.7986	0.7997	0.8007	0.8018	0.8028	0.8039	0.8049	0.8059	0.8070	0.8080
	cos	0.6018	0.6004	0.5990	0.5976	0.5962	0.5948	0.5934	0.5920	0.5906	0.5892
	tan	1.3370	1.3319	1.3267	1.3216	1.3165	1.3114	1.3064	1.3013	1.2963	1.2912
54	sin	0.8090	0.8100	0.8111	0.8121	0.8131	0.8141	0.8151	0.8161	0.8171	0.8181
	cos	0.5878	0.5864	0.5850	0.5835	0.5821	0.5807	0.5793	0.5779	0.5764	0.5750
	tan	1.3764	1.3614	1.3465	1.3316	1.3168	1.3021	1.2874	1.2728	1.2583	1.2438
55	sin	0.8192	0.8202	0.8211	0.8221	0.8231	0.8241	0.8251	0.8261	0.8271	0.8281
	cos	0.5736	0.5721	0.5707	0.5693	0.5678	0.5664	0.5650	0.5635	0.5621	0.5606
	tan	1.4281	1.4235	1.4188	1.4142	1.4096	1.4050	1.4006	1.3960	1.3915	1.3870
56	sin	0.8390	0.8399	0.8408	0.8417	0.8426	0.8435	0.8444	0.8453	0.8462	0.8471
	cos	0.5592	0.5577	0.5563	0.5548	0.5534	0.5519	0.5505	0.5490	0.5476	0.5461
	tan	1.4836	1.4822	1.4808	1.4794	1.4781	1.4767	1.4754	1.4740	1.4727	1.4714
57	sin	0.8587	0.8596	0.8605	0.8614	0.8623	0.8632	0.8641	0.8650	0.8659	0.8668
	cos	0.5446	0.5433	0.5419	0.5405	0.5391	0.5377	0.5363	0.5349	0.5335	0.5321
	tan	1.5399	1.5458	1.5517	1.5577	1.5637	1.5697	1.5757	1.5818	1.5879	1.5941
58	sin	0.8680	0.8690	0.8699	0.8708	0.8717	0.8726	0.8735	0.8744	0.8753	0.8762
	cos	0.5299	0.5284	0.5270	0.5255	0.5240	0.5226	0.5210	0.5195	0.5180	0.5165
	tan	1.6003	1.6066	1.6128	1.6191	1.6255	1.6319	1.6383	1.6447	1.6512	1.6577
59	sin	0.8872	0.8881	0.8890	0.8899	0.8907	0.8916	0.8925	0.8934	0.8943	0.8952
	cos	0.5150	0.5135	0.5120	0.5105	0.5090	0.5075	0.5060	0.5045	0.5030	0.5015
	tan	1.6643	1.6709	1.6775	1.6842	1.6909	1.6977	1.7045	1.7113	1.7182	1.7251
Degr.	Function	0'	6'	12'	18'	24'	30'	36'	42'	48'	54'

60°-74.9°

Degs.	Function	0.0°	0.1°	0.2°	0.3°	0.4°	0.5°	0.6°	0.7°	0.8°	0.9°
60	sin	0.8660	0.8669	0.8678	0.8686	0.8694	0.8704	0.8712	0.8721	0.8729	0.8738
	cos	0.5000	0.4985	0.4970	0.4955	0.4935	0.4924	0.4909	0.4894	0.4879	0.4863
	tan	1.7321	1.7391	1.7461	1.7532	1.7603	1.7675	1.7747	1.7820	1.7893	1.7966
61	sin	0.8746	0.8755	0.8763	0.8771	0.8780	0.8788	0.8796	0.8805	0.8813	0.8821
	cos	0.4848	0.4833	0.4818	0.4802	0.4787	0.4772	0.4756	0.4741	0.4726	0.4710
	tan	1.8040	1.8115	1.8190	1.8265	1.8341	1.8418	1.8495	1.8572	1.8650	1.8728
62	sin	0.8839	0.8838	0.8846	0.8854	0.8863	0.8870	0.8878	0.8886	0.8894	0.8902
	cos	0.4666	0.4679	0.4664	0.4648	0.4633	0.4617	0.4602	0.4586	0.4571	0.4555
	tan	1.8907	1.8987	1.8967	1.9047	1.9128	1.9210	1.9292	1.9375	1.9458	1.9542
63	sin	0.8910	0.8918	0.8926	0.8934	0.8942	0.8949	0.8957	0.8965	0.8973	0.8980
	cos	0.4540	0.4534	0.4528	0.4520	0.4512	0.4504	0.4496	0.4488	0.4481	0.4473
	tan	1.9626	1.9711	1.9797	1.9883	1.9970	2.0057	2.0145	2.0233	2.0323	2.0412
64	sin	0.8988	0.8996	0.9003	0.9011	0.9018	0.9026	0.9033	0.9041	0.9048	0.9056
	cos	0.4384	0.4368	0.4352	0.4337	0.4321	0.4305	0.4289	0.4274	0.4259	0.4243
	tan	2.0503	2.0594	2.0686	2.0778	2.0872	2.0965	2.1060	2.1155	2.1251	2.1348
65	sin	0.9063	0.9070	0.9078	0.9085	0.9092	0.9100	0.9107	0.9114	0.9121	0.9128
	cos	0.4226	0.4210	0.4195	0.4179	0.4163	0.4147	0.4131	0.4115	0.4099	0.4083
	tan	2.1445	2.1543	2.1642	2.1742	2.1842	2.1943	2.2045	2.2148	2.2251	2.2355
66	sin	0.9135	0.9143	0.9150	0.9157	0.9164	0.9171	0.9178	0.9184	0.9191	0.9198
	cos	0.4067	0.4051	0.4035	0.4019	0.4003	0.3987	0.3971	0.3955	0.3939	0.3923
	tan	2.2480	2.2586	2.2693	2.2781	2.2889	2.2998	2.3109	2.3220	2.3333	2.3445
67	sin	0.9206	0.9213	0.9219	0.9225	0.9232	0.9239	0.9245	0.9252	0.9259	0.9265
	cos	0.3907	0.3891	0.3875	0.3859	0.3843	0.3827	0.3811	0.3795	0.3779	0.3763
	tan	2.3559	2.3673	2.3789	2.3906	2.4023	2.4142	2.4262	2.4383	2.4504	2.4627
68	sin	0.9273	0.9278	0.9283	0.9289	0.9295	0.9301	0.9307	0.9313	0.9319	0.9325
	cos	0.3746	0.3730	0.3714	0.3697	0.3681	0.3665	0.3649	0.3633	0.3616	0.3600
	tan	2.4751	2.4876	2.5002	2.5129	2.5257	2.5385	2.5517	2.5649	2.5783	2.5916
69	sin	0.9336	0.9343	0.9348	0.9354	0.9361	0.9367	0.9373	0.9379	0.9385	0.9391
	cos	0.3584	0.3567	0.3551	0.3535	0.3518	0.3502	0.3486	0.3469	0.3453	0.3437
	tan	2.6051	2.6187	2.6325	2.6464	2.6604	2.6746	2.6889	2.7034	2.7179	2.7326
70	sin	0.9397	0.9403	0.9409	0.9415	0.9421	0.9426	0.9432	0.9438	0.9444	0.9449
	cos	0.3420	0.3404	0.3387	0.3371	0.3355	0.3338	0.3323	0.3306	0.3289	0.3273
	tan	2.7475	2.7635	2.7776	2.7929	2.8085	2.8249	2.8397	2.8556	2.8716	2.8878
71	sin	0.9455	0.9461	0.9466	0.9472	0.9478	0.9483	0.9489	0.9494	0.9500	0.9506
	cos	0.3256	0.3239	0.3223	0.3206	0.3190	0.3173	0.3156	0.3140	0.3123	0.3107
	tan	2.9042	2.9208	2.9375	2.9544	2.9714	2.9887	3.0061	3.0237	3.0416	3.0595
72	sin	0.9511	0.9516	0.9521	0.9527	0.9532	0.9537	0.9542	0.9548	0.9553	0.9558
	cos	0.3090	0.3074	0.3057	0.3040	0.3024	0.3007	0.2990	0.2974	0.2957	0.2940
	tan	3.0777	3.0961	3.1146	3.1334	3.1524	3.1716	3.1910	3.2106	3.2306	3.2506
73	sin	0.9563	0.9568	0.9573	0.9578	0.9583	0.9588	0.9593	0.9598	0.9603	0.9608
	cos	0.2924	0.2907	0.2890	0.2874	0.2857	0.2840	0.2823	0.2807	0.2790	0.2773
	tan	3.2709	3.2914	3.3122	3.3332	3.3544	3.3759	3.3977	3.4197	3.4420	3.4646
74	sin	0.9613	0.9617	0.9622	0.9627	0.9632	0.9636	0.9641	0.9646	0.9650	0.9655
	cos	0.2756	0.2740	0.2723	0.2706	0.2689	0.2672	0.2655	0.2639	0.2623	0.2606
	tan	3.4874	3.5105	3.5339	3.5576	3.5816	3.6059	3.6305	3.6554	3.6806	3.7053
Degs.	Function	0'	6'	12'	18'	24'	30'	36'	42'	48'	54'

75°-89°

Degr.	Function	0.0°	0.1°	0.2°	0.3°	0.4°	0.5°	0.6°	0.7°	0.8°	0.9°
75	sin	0.9659	0.9664	0.9668	0.9673	0.9677	0.9681	0.9685	0.9689	0.9694	0.9698
	cos	0.2588	0.2571	0.2554	0.2538	0.2521	0.2504	0.2487	0.2470	0.2453	0.2436
	tan	3.7321	3.7583	3.7848	3.8118	3.8391	3.8667	3.8947	3.9233	3.9520	3.9812
76	sin	0.9703	0.9707	0.9711	0.9715	0.9720	0.9724	0.9728	0.9733	0.9738	0.9743
	cos	0.2419	0.2402	0.2385	0.2368	0.2351	0.2334	0.2317	0.2300	0.2284	0.2267
	tan	4.0108	4.0408	4.0713	4.1022	4.1335	4.1653	4.1978	4.2308	4.2645	4.2978
77	sin	0.9744	0.9748	0.9751	0.9755	0.9759	0.9763	0.9767	0.9770	0.9774	0.9778
	cos	0.2250	0.2232	0.2215	0.2198	0.2181	0.2164	0.2147	0.2130	0.2113	0.2096
	tan	4.3315	4.3682	4.4015	4.4374	4.4737	4.5107	4.5483	4.5864	4.6252	4.6646
78	sin	0.9781	0.9785	0.9789	0.9792	0.9796	0.9799	0.9803	0.9806	0.9810	0.9813
	cos	0.2079	0.2062	0.2045	0.2028	0.2011	0.1994	0.1977	0.1960	0.1943	0.1926
	tan	4.7046	4.7453	4.7867	4.8288	4.8716	4.9152	4.9594	5.0045	5.0504	5.0970
79	sin	0.9816	0.9820	0.9823	0.9826	0.9829	0.9833	0.9836	0.9839	0.9842	0.9845
	cos	0.1908	0.1891	0.1874	0.1857	0.1840	0.1822	0.1805	0.1788	0.1771	0.1754
	tan	5.1446	5.1929	5.2422	5.2924	5.3435	5.3955	5.4486	5.5026	5.5578	5.6140
80	sin	0.9848	0.9851	0.9854	0.9857	0.9860	0.9863	0.9866	0.9869	0.9871	0.9874
	cos	0.1736	0.1719	0.1702	0.1685	0.1668	0.1650	0.1633	0.1616	0.1599	0.1582
	tan	5.6713	5.7297	5.7894	5.8502	5.9124	5.9758	6.0405	6.1066	6.1742	6.2432
81	sin	0.9877	0.9880	0.9882	0.9885	0.9888	0.9890	0.9893	0.9895	0.9898	0.9900
	cos	0.1564	0.1547	0.1530	0.1513	0.1495	0.1478	0.1461	0.1444	0.1426	0.1409
	tan	6.3138	6.3859	6.4596	6.5350	6.6122	6.6912	6.7720	6.8548	6.9396	7.0264
82	sin	0.9903	0.9905	0.9907	0.9910	0.9912	0.9914	0.9917	0.9919	0.9921	0.9923
	cos	0.1392	0.1374	0.1357	0.1340	0.1323	0.1305	0.1288	0.1271	0.1253	0.1236
	tan	7.1154	7.2066	7.3002	7.3962	7.4947	7.5958	7.6996	7.8062	7.9158	8.0285
83	sin	0.9925	0.9928	0.9930	0.9932	0.9934	0.9936	0.9938	0.9940	0.9942	0.9943
	cos	0.1219	0.1201	0.1184	0.1167	0.1149	0.1132	0.1115	0.1097	0.1080	0.1063
	tan	8.1443	8.2636	8.3863	8.5126	8.6427	8.7769	8.9152	9.0579	9.2052	9.3572
84	sin	0.9945	0.9947	0.9949	0.9951	0.9952	0.9954	0.9956	0.9957	0.9959	0.9960
	cos	0.1045	0.1028	0.1011	0.0993	0.0976	0.0958	0.0941	0.0924	0.0906	0.0889
	tan	9.5144	9.6768	9.8448	10.02	10.20	10.39	10.58	10.78	10.99	11.20
85	sin	0.9962	0.9963	0.9965	0.9966	0.9968	0.9969	0.9971	0.9972	0.9973	0.9974
	cos	0.0872	0.0854	0.0837	0.0819	0.0802	0.0785	0.0767	0.0750	0.0733	0.0715
	tan	11.43	11.66	11.91	12.16	12.43	12.71	13.00	13.30	13.62	13.95
86	sin	0.9976	0.9977	0.9978	0.9979	0.9980	0.9981	0.9982	0.9983	0.9984	0.9985
	cos	0.0698	0.0680	0.0663	0.0645	0.0628	0.0610	0.0593	0.0576	0.0558	0.0541
	tan	14.30	14.67	15.06	15.46	15.89	16.35	16.83	17.34	17.89	18.46
87	sin	0.9986	0.9987	0.9988	0.9989	0.9990	0.9990	0.9991	0.9992	0.9993	0.9993
	cos	0.0523	0.0506	0.0488	0.0471	0.0454	0.0436	0.0419	0.0401	0.0384	0.0366
	tan	19.08	19.74	20.45	21.20	22.02	22.90	23.86	24.90	26.03	27.27
88	sin	0.9994	0.9995	0.9995	0.9996	0.9996	0.9997	0.9997	0.9997	0.9998	0.9998
	cos	0.0349	0.0332	0.0314	0.0297	0.0279	0.0262	0.0244	0.0227	0.0209	0.0192
	tan	28.64	30.14	31.82	33.60	35.50	38.19	40.92	44.07	47.74	52.06
89	sin	0.9998	0.9999	0.9999	0.9999	0.9999	1.000	1.000	1.000	1.000	1.000
	cos	0.0175	0.0157	0.0140	0.0122	0.0105	0.0087	0.0070	0.0063	0.0055	0.0047
	tan	57.29	63.66	71.62	81.85	95.49	114.6	143.2	191.0	266.5	373.0
Degr.	Function	0'	6'	12'	18'	24'	30'	36'	42'	48'	54'



## APPENDIX V

### MATHEMATICAL SYMBOLS

SYMBOL	NAME OR MEANING	SYMBOL	NAME OR MEANING
+	Addition or positive value	$\sqrt{\quad}$	Square root symbol
-	Subtraction or negative value	$\sqrt{\hspace{1.5cm}}$	Square root symbol with vinculum. Vinculum is made long enough to cover all factors of the number whose square root is to be taken.
$\pm$	Positive or negative value	$\sqrt[n]{\quad}$	Radical symbol. Letter n represents a number indicating which root is to be taken.
.	Multiplication dot (Centered; not to be mistaken for decimal point.)	i or j	Imaginary unit; operator j for electronics; represents $\sqrt{-1}$ .
x	Multiplication symbol	$\infty$	Infinity symbol
( )	Parentheses	...	Ellipsis. Used in series of numbers in which successive numbers are predictable by their conformance to a pattern; meaning is approximated by "etc."
[ ]	Brackets	$\log_a N$	Logarithm of N to the base a.
{ }	Braces	$\log N$	Logarithm of N to the base 10. (understood)
—	Vinculum (overscore)	$\ln N$	Natural or Napierian logarithm of N. Base of the natural or Napierian logarithm system.
%	Percent	$ X $	Absolute value of X.
÷	Division symbol	$\pi$	Pi. The ratio of the circumference of any circle to its diameter. Approximate numerical value is 22/7.
:	Ratio symbol	$\therefore$	Therefore
::	Proportion symbol	$\sphericalangle$ or $\sphericalangle$	Angle
=	Equality symbol		
$\neq$	"Not equal" symbol		
<	Less than		
$\leq$	Less than or equal to		
>	Greater than		
$\geq$	Greater than or equal to		
$\propto$	"Varies directly as" or "is proportional to" (Not to be mistaken for Greek alpha ( $\alpha$ ).)		



## APPENDIX VI

### FORMULAS

#### Areas

$A = s^2$  The area of a square is equal to the square of a side.

$A = \frac{b}{2} h$  The area of a triangle is equal to one half the base times the height.

$A = \pi r^2$  The area of a circle is equal to the radius squared times pi.

$A = lw$  The area of a rectangle is equal to the length times the width.

$A = Ch$  The lateral area of a cylinder is equal to the circumference of the base times the height.

#### Areas

$A = 4\pi r^2$  The square area of a sphere is equal to 4 times pi times the radius squared.

#### Volumes

$V = e^3$  The volume of a cube equals the cube of an edge.

$V = Bh$  The volume of a rectangular solid or cylinder equals the area of the base times the height.

$V = \frac{4}{3} \pi r^3$  The volume of a sphere equals  $\frac{4}{3}$  pi times the radius cubed.



## APPENDIX VII

### WEIGHTS AND MEASURES

#### Dry Measure

2 cups = 1 pint (pt)  
2 pints = 1 quart (qt)  
4 quarts = 1 gallon (gal)  
8 quarts = 1 peck (pk)  
4 pecks = 1 bushel (bu)

#### Liquid Measure

3 teaspoons (tsp) = 1 tablespoon (tbsp)  
16 tablespoons = 1 cup  
2 cups = 1 pint  
16 fluid ounces (oz) = 1 pint  
2 pints = 1 quart  
4 quarts = 1 gallon  
31.5 gallons = 1 barrel (bbl)  
231 cubic inches = 1 gallon  
7.48 gallons = 1 cubic foot (cu ft)

#### Weight

16 ounces = 1 pound (lb)  
2,000 pounds = 1 short ton (T)  
2,240 pounds = 1 long ton

#### Distance

12 inches = 1 foot (ft)  
3 feet = 1 yard (yd)  
5-1/2 yards = 1 rod (rd)  
16-1/2 feet = 1 rod  
1,760 yards = 1 statute mile (mi)  
5,280 feet = 1 statute mile

#### Area

144 square inches = 1 square foot (sq ft)  
9 square feet = 1 square yd (sq yd)  
30-1/4 square yards = 1 square rod  
160 square rods = 1 acre (A)  
640 acres = 1 square mile (sq mi)

#### Volume

1,728 cubic inches = 1 cubic foot  
27 cubic feet = 1 cubic yard (cu yd)

#### Counting Units

12 units = 1 dozen (doz)  
12 dozens = 1 gross  
144 units = 1 gross  
24 sheets = 1 quire  
480 sheets = 1 ream

#### Equivalents

1 cubic foot of water weighs 62.5 pounds (approx) = 1,000 ounces  
1 gallon of water weighs 8-1/3 pounds (approx)  
1 cubic foot = 7.48 gallons  
1 inch = 2.54 centimeters  
1 foot = 30.4801 centimeters  
1 meter = 39.37 inches  
1 liter = 1.05668 quarts (liquid) = 0.90808 quart (dry)  
1 nautical mile = 6,080 feet (approx)  
1 fathom = 6 feet  
1 shot of chain = 15 fathoms



# INDEX

## A

Absorption of heat, 4-3  
Ac power measurement, 6-6  
Acoustics, 4-26  
Algebra, 1-12  
    coefficient, 1-14  
    distributive law of algebra, 1-13  
    exponent, 1-16  
    expression, 1-14  
    laws, 1-13  
    radical, 1-16  
    root, 1-16  
    sum, 1-14  
    term, 1-14  
Analog oscilloscope, 6-17  
Analog-to-digital converter (ADC), 6-18  
Anti-static material, 5-47  
Apparel, protective, 5-46  
Associative law of algebra, 1-13  
Atom, 3-8  
    electron shell, 3-9  
    number, 3-8  
    weight, 3-8  
Audibility, 4-25  
Automatic test equipment (ATE), 6-25  
Automatic test system (ATS), 6-25

## B

Bench procedures, troubleshooting, 5-12  
    resistance checks, 5-14  
    signal tracing, 5-13  
    test probe substitution, 5-13  
    voltage checks, 5-13  
Bonding, 5-40  
Boyle's gas law, 3-12

## C

Cable straps, 5-30  
Calibration, 6-1  
Candlepower, 4-17  
Cardiopulmonary resuscitation (CPR), 5-1  
Charles' gas law, 3-12  
Circuits, troubleshooting, 5-12  
Coefficient, 1-14  
Color, 4-21  
Color coding, 5-17  
Commutative law of algebra, 1-13  
Components, color codes, 5-17  
Components, defective, 5-15  
Compounds, 3-9  
Compressed air, hazards, 5-7  
Conduction of heat, 4-1  
Conduit, 5-34  
Connectors, electrical, 5-33, 5-38

Consolidated Automated Support System (CASS), 6-25  
Continuity test, 5-11, 6-5  
Convection of heat, 4-2  
Conventional counter, 6-9  
Coordinates, rectangular, 2-9  
Current measurement, 6-4

## D

Dc power measurement, 6-5  
Decibel, 4-25  
Density, 3-6  
Diffraction, 4-15  
Digital multimeters (DMM), 6-2  
Digitizing storage oscilloscope (DSO), 6-18  
Digitizing phosphor oscilloscope (DPO), 6-19  
Diode test, 6-5  
Distributive law of algebra, 1-13  
Doppler effect, 4-16

## E

Echo, 4-27  
Electric shock, 5-3  
Electronic counters, 6-8  
Electrostatic discharge (ESD), 5-44  
    apparel, protective, 5-46  
    component susceptibility, 5-45  
    control, 5-45  
    generators, 5-46  
    grounding, 5-46  
    handling and packaging, 5-47  
    triboelectric series, 5-44  
ESD-sensitive devices (ESDS), 5-45  
Elements, 3-8  
    atomic number, 3-8  
    atomic weight, 3-8  
Energy, 3-6  
    efficiency, 3-17  
    friction, 3-18  
    kinetic, 3-7, 3-17  
    law of conservation of matter and energy, 3-6  
    potential, 3-17  
Equations, 2-1  
    graphs, 2-10  
    linear, 2-1, 2-9  
    literal, 2-3  
    proportions, 2-5  
    ratios, 2-5  
    rectangular coordinates, 2-9  
    variations, 2-6  
Exponent, 1-16

## F

Fire, electrical, 5-6

Fluke multimeter, 6-3, 6-5  
 Force, 3-3, 3-7, 3-15  
   acceleration, 3-16  
   inertia, 3-16  
   mechanical advantage, 3-18  
   momentum, 3-16  
 Foreign object damage (FOD), 5-4  
 Formulas, 2-3  
 Fractions, 1-1  
   addition, 1-2  
   division, 1-5  
   improper, 1-1  
   like fractions, 1-2  
   lowest common denominator, 1-3  
   mixed number, 1-1  
   multiplication, 1-4  
   proper, 1-1  
   reciprocal, 1-5  
   reduction to lowest term, 1-2  
   subtraction, 1-2  
 Frequency counters, 6-8  
 Friction, 3-18  
 Fuel, safety, 5-7  
 Fusion, heat, 4-8

## G

Gases, 3-11  
   Boyle's law, 3-12  
   Charles' law, 3-12  
   general gas law, 3-13  
   pressure, 3-12  
 Gravity, 3-6, 3-14  
 Grounded circuit test, 5-12  
 Grounding, 5-5, 5-46

## H

Hardware, 5-32  
 Harmonic distortion, 6-24  
 Hazards, 5-1  
   compressed air, 5-7  
   fire, 5-6  
   fuel, 5-7  
   grounding, 5-5  
   precautions, 5-1  
   tools, 5-4  
   volatile liquid, 5-7  
 Heat, 4-1  
   conduction, 4-1  
   convection, 4-2  
   fusion, 4-8  
   measurement, 4-6  
   radiation, 4-2  
   specific heat, 4-7  
   temperature, 4-3  
   thermal expansion, 4-5  
   transfer, 4-1  
   vaporization, 4-8

## I

Illumination, 4-17  
 Inertia, 3-16  
 Inspections, 5-9  
 Interference, waves, 4-15, 4-27

## L

Lenses, 4-21  
 Light, 4-17  
   characteristics, 4-17  
   frequency and color, 4-21  
 Linear equations, 2-1, 2-9  
 Liquids, 3-11  
 Longitudinal waves, 4-11  
 Lowest common denominator (LCD), 1-3  
 Lumen, 4-18  
 Luminance, 4-18  
 Lux, 4-18

## M

Maintenance categories, 5-8  
   scheduled, 5-8  
   unscheduled, 5-9  
 Mass, measurement, 3-3  
 Mass, motion, 3-15, 3-19  
 Matter, 3-6  
   atoms, 3-8  
   compounds, 3-9  
   density, 3-6  
   gases, 3-11  
   gravity, 3-6  
   law of conservation of matter and energy, 3-6  
   liquids, 3-11  
   mixtures, 3-9  
   properties, 3-6  
   solids, 3-10  
   space, 3-6  
   states, 3-10  
   structure, 3-8  
 Measurement, 3-1  
   amplitude, 6-20  
   current, 6-4  
   derived units, 3-4  
   digital multimeters (DMM), 6-2  
   English units, 3-1  
   force, 3-3  
   frequency, 6-9, 6-11, 6-13, 6-21, 6-22  
   harmonics, 6-24  
   mass, 3-3  
   megohmmeter, 6-7  
   metric units, 3-1  
   period, 6-10  
   power, 3-5, 6-5, 6-6, 6-14  
   radio frequency, 6-6  
   resistance, 5-14, 6-4  
   signals, 5-13, 6-14  
   sound, 4-25  
   speed, 3-4  
   temperature, 4-6



Measurement—Continued  
test equipment, 6-2  
time, 3-4, 6-8, 6-10, 6-20  
velocity, 3-5  
voltage, 5-13, 6-2, 6-7, 6-20  
volume, 3-2  
weight, 3-3  
work, 3-5  
Megohmmeter (megger), 6-7  
Mixed numbers, 1-1  
Mixtures, 3-9  
Monomial operations, 1-16  
division, 1-17  
multiplication, 1-17  
Multimeters, digital, (DMM), 6-2

## O

Ohm's law, 6-5  
Ohmmeter, 5-10, 5-14  
Oscilloscopes, 6-16

## P

Phot, 4-18  
Pitch, sound, 4-24  
Polynomial operations, 1-16  
addition and subtraction, 1-17  
binomials, 1-20  
division, 1-18  
multiplication, 1-18  
Power measurement, 3-5, 6-5, 6-6, 6-14  
Powers of ten, 1-22  
Preventive maintenance, 5-8  
Preventive maintenance services (PMS), 5-9  
Prism, 4-20  
Proportions, 2-5

## R

Radiation of heat, 4-2  
Radical, 1-16  
Radio frequency (RF) measurement, 6-6  
Ratios, 2-5  
Reciprocal counter, 6-10  
Reduction of fractions, 1-2  
Reflection, 4-12, 4-19  
Reflectors, 4-19  
Refraction, 4-13, 4-19  
Replaceable assemblies, 5-42  
Resistance measurement, 5-14, 6-4  
Resonance, 4-28  
Reverberation, 4-27  
Revolving bodies, 3-19  
Root, 1-16

## S

Safety, 5-1  
compressed air, 5-7  
fire, 5-6

Safety—Continued  
general precautions, 5-1  
grounding, 5-5  
tools, 5-4  
volatile liquid, 5-7  
Scheduled maintenance, 5-8  
Scientific notation, 1-22  
Shock mounts, 5-39  
Shop replaceable assemblies (SRA), 5-42  
Signal measurement, 5-13, 6-16, 6-20  
Signed numbers, 1-7  
addition, 1-9  
division, 1-11  
multiplication, 1-10  
subtraction, 1-9

Solids, 3-10  
adhesion and cohesion, 3-10  
elasticity, 3-11  
tensile strength, 3-11

Sound, 4-23  
acoustics, 4-27  
characteristics, 4-24  
conduction, 4-23  
measurement, 4-25  
speed, 4-23  
transmission, 4-23  
Spectrum analyzer, 6-22  
Speed, measurement, 3-4  
Speed of sound, 4-23  
Standing waves, 4-12  
Static electricity, 5-44

## T

Temperature, 4-3  
Celsius, 4-3  
Fahrenheit, 4-3  
Kelvin, 4-3  
measurement, 4-6  
Rankine, 4-3  
Terminals, wiring, 5-36  
Test equipment, 6-1  
calibration, 6-1  
care and handling, 6-1  
Consolidated Automatic Support System  
(CASS), 6-25  
measurement, 6-2  
repair, 6-1  
test program sets (TPS), 6-25  
Test probe substitution, 5-13  
Thermal expansion, 4-5  
Thermometer, 4-6  
liquid, 4-6  
resistance, 4-7  
solid, 4-6  
thermocouple, 4-7  
Time measurement, 3-4, 6-8, 6-20  
Tone, 4-24  
Tools, safety, 5-4  
Transmission, sound, 4-23  
Transverse waves, 4-11  
Triboelectric effect, 5-44

Troubleshooting, 5-9  
  aircraft procedures, 5-10  
  bench procedures, 5-12  
  continuity test, 5-11  
  grounded circuit test, 5-12  
  short test, 5-12  
  voltage test, 5-12

## V

Valence bond, 3-10  
Vaporization, 4-8  
Variations, equations, 2-6  
  direct, 2-6  
  inverse, 2-7  
  joint, 2-8  
Velocity, measurement, 3-5  
Voltage measurement, 5-13, 6-2, 6-6, 6-20  
Voltmeters, 6-6  
Volume, 3-2, 3-6

## W

Waves, 4-9  
  diffraction, 4-15  
  Doppler effect, 4-16

Waves—Continued  
  front, 4-13  
  interference, 4-15  
  motion, 4-10  
  parameters, 4-10  
  reflection, 4-12  
  refraction, 4-13  
  sound, 4-23  
  spectrum analyzer, 6-22  
Weapons replaceable assemblies (WRA), 5-42  
Weight, 3-3  
Wiring, 5-22  
  conduit, 5-34  
  connectors, 5-33  
  grouping, 5-28  
  heat shrinkable tubing, 5-30  
  identification codes, 5-23  
  installation, 5-27  
  junction boxes, 5-37  
  lock wire, 5-38  
  marking, 5-23  
  replacement, 5-15  
  shear wire, 5-39  
  stripping, 5-32  
  support clamps, 5-35  
  terminals, 5-36  
Work, measurement, 3-5

---

---

# *Assignment Questions*

---

---

**Information:** The text pages that you are to study are provided at the beginning of the assignment questions.



# ASSIGNMENT 1

Textbook Assignment: "MATHEMATICS - BASICS," Pages 1-1 through 1-24.

---

- 1-1. An expression that represents a part, or several equal parts, of a unit is known as what?
1. Integer
  2. Fraction
  3. Whole number
  4. Negative number
- 1-2. In the fraction  $\frac{2}{3}$ , the number 2 is known as what?
1. Denominator
  2. Enumerator
  3. Numerator
  4. Enunciator
- 1-3. The number below or after the bar in a fraction is known by what term?
1. Denominator
  2. Enumerator
  3. Numerator
  4. Enunciator
- 1-4. Which of the following is an example of a proper fraction?
1.  $\frac{3}{2}$
  2.  $\frac{6}{5}$
  3.  $\frac{9}{4}$
  4.  $\frac{2}{7}$
- 1-5. Which of the following is an example of an improper fraction?
1.  $\frac{2}{3}$
  2.  $\frac{5}{8}$
  3.  $\frac{2}{1}$
  4.  $\frac{9}{16}$
- 1-6. Convert  $3\frac{2}{3}$  to an improper fraction.
1.  $\frac{6}{3}$
  2.  $\frac{6}{9}$
  3.  $\frac{11}{3}$
  4.  $\frac{5}{3}$
- 1-7. Convert  $6\frac{7}{8}$  to an improper fraction.
1.  $\frac{42}{8}$
  2.  $\frac{48}{8}$
  3.  $\frac{50}{8}$
  4.  $\frac{55}{8}$
- 1-8. Convert  $5\frac{5}{16}$  to an improper fraction.
1.  $\frac{25}{16}$
  2.  $\frac{85}{16}$
  3.  $\frac{80}{16}$
  4.  $\frac{26}{16}$
- 1-9. Convert  $\frac{33}{6}$  to a mixed number.
1.  $5\frac{1}{2}$
  2.  $5\frac{2}{3}$
  3.  $5\frac{1}{3}$
  4.  $5\frac{5}{6}$

1-10. Convert  $\frac{13}{3}$  to a mixed number.

1.  $4\frac{2}{3}$
2.  $4\frac{1}{3}$
3.  $3\frac{2}{3}$
4.  $5\frac{1}{3}$

1-11. Convert  $\frac{87}{23}$  to a mixed number.

1.  $2\frac{17}{23}$
2.  $3\frac{13}{23}$
3.  $3\frac{18}{23}$
4.  $4\frac{6}{23}$

1-12. Reduce  $\frac{6}{9}$  to the lowest term.

1.  $\frac{1}{3}$
2.  $\frac{2}{3}$
3.  $\frac{2}{6}$
4.  $\frac{3}{6}$

1-13. Reduce  $\frac{39}{104}$  to the lowest term.

1.  $\frac{13}{34}$
2.  $\frac{1}{3}$
3.  $\frac{6}{52}$
4.  $\frac{3}{8}$

1-14. The sum of  $\frac{2}{5}$  and  $\frac{1}{5}$  equals?

1.  $\frac{3}{5}$
2.  $\frac{3}{25}$
3.  $\frac{3}{10}$
4.  $\frac{2}{25}$

1-15. The sum of  $\frac{2}{3}$  and  $\frac{2}{3}$  equals?

1.  $\frac{4}{9}$
2.  $1\frac{1}{3}$
3.  $\frac{4}{6}$
4.  $2\frac{2}{3}$

1-16. The sum of  $3\frac{7}{8}$  and  $2\frac{5}{16}$  equals?

1.  $5\frac{12}{16}$
2.  $6\frac{2}{3}$
3.  $6\frac{3}{16}$
4.  $5\frac{1}{2}$

1-17. How much is  $\frac{2}{5}$  subtracted from  $\frac{3}{5}$ ?

1. 1
2.  $\frac{1}{5}$
3.  $\frac{1}{10}$
4.  $\frac{6}{25}$

1-18. How much is  $\frac{2}{6}$  subtracted from  $\frac{16}{24}$ ?

1.  $\frac{7}{9}$
2.  $\frac{18}{30}$
3.  $\frac{1}{3}$
4.  $\frac{1}{4}$

1-19. How much is  $1\frac{7}{8}$  subtracted from  $3\frac{2}{5}$ ?

1.  $1\frac{1}{4}$
2.  $1\frac{3}{8}$
3.  $1\frac{5}{40}$
4.  $1\frac{21}{40}$

1-20. What is the product of  $\frac{1}{5}$  and  $\frac{2}{5}$ ?

1.  $\frac{2}{25}$
2.  $\frac{2}{5}$
3.  $\frac{2}{10}$
4.  $\frac{3}{10}$

1-21. What is the product of  $\frac{2}{3}$  and  $\frac{3}{7}$ ?

1.  $\frac{1}{2}$
2.  $\frac{2}{7}$
3.  $\frac{5}{21}$
4.  $\frac{3}{5}$

1-22. What is the product of  $1\frac{2}{3}$  and  $2\frac{3}{5}$ ?

1.  $2\frac{3}{5}$
2.  $2\frac{1}{3}$
3.  $4\frac{1}{3}$
4.  $4\frac{3}{5}$

1-23. Solve for the following:  $\frac{2}{3} \times \frac{1}{4} \times \frac{3}{8} = ?$

1.  $\frac{3}{5}$
2.  $\frac{3}{16}$
3.  $\frac{5}{26}$
4.  $\frac{1}{16}$

1-24.  $\frac{1}{3} \div \frac{1}{4} = ?$

1.  $\frac{2}{7}$
2.  $\frac{1}{12}$
3.  $1\frac{1}{3}$
4.  $1\frac{2}{3}$

1-25. What is the reciprocal of  $\frac{5}{15}$ ?

1. 1
2.  $\frac{15}{5}$
3.  $\frac{1}{3}$
4.  $1\frac{1}{3}$

1-26. Solve for the following:  $2\frac{2}{3} \div 1\frac{3}{7}=?$

1.  $1\frac{13}{15}$
2.  $1\frac{3}{5}$
3.  $1\frac{3}{4}$
4.  $1\frac{1}{2}$

1-27. Refer to figure 1-3 view (B) of your text. What is the total resistance of the circuit?

1.  $\frac{7}{10}$  ohms
2.  $1\frac{1}{3}$  ohms
3.  $1\frac{1}{2}$  ohms
4.  $1\frac{1}{4}$  ohms

1-28. Which of the following is an example of a signed number?

1.  $\frac{2}{3}$
2.  $-\frac{3}{2}$
3.  $+1\frac{1}{3}$
4. Both 2 and 3

1-29. What is the sum of  $-4$  and  $+8$ ?

1. 8
2.  $-8$
3.  $-4$
4. 4

1-30. Solve for the following:  $-8+(-2)=?$

1. 10
2.  $-10$
3. 6
4.  $-6$

1-31. Solve for the following:  $-5-3=?$

1. 8
2.  $-8$
3. 2
4.  $-2$

1-32. Solve for the following:  $-3 - (-6) = ?$

1.  $-9$
2. 9
3. 3
4.  $-3$

1-33. Solve for the following;  $3(-5)=?$

1. 15
2.  $-15$
3. 8
4.  $-8$

1-34. Solve for the following:  $-3(4)=?$

1. 7
2.  $-7$
3. 12
4.  $-12$

1-35. Solve for the following:  $-4(-7)=?$

1. 11
2.  $-11$
3. 28
4.  $-28$

1-36. Solve for the following:  $-3(-2)=?$

1.  $-6$
2. 6
3.  $-8$
4. 8

1-37. Solve for the following:  $12 \div -2=?$

1.  $-6$
2. 6
3. 24
4.  $-24$

1-38. Solve for the following:  $-9 \div 3=?$

1. 27
2.  $-27$
3. 3
4.  $-3$

1-39. Solve for the following:  $-12 \div -4=?$

1.  $-3$
2. 3
3. 48
4.  $-48$

1-40.  $a+b=b+a$  is a form of what algebraic law?

1. Commutative
2. Distributive
3. Associative
4. Iterative



1-41. Which of the following is an example of the associative laws of algebra?

1.  $a+b+c=c+b+a=b+c+a$
2.  $a+b+c=ab+ac=bc+ba$
3.  $a+b+c=(a+b)+c=a+(b+c)$
4.  $a+b+c=a(ab+bc+cb)=b(ab+bb=bc)$

1-42. Given any mathematical problem with multiple signs of operation, which of the following is the proper order of operation?

1. Add, subtract, multiply, then divide
2. Multiply, divide, add, then subtract
3. Divide, multiply, subtract, then add
4. Subtract, add, divide, then multiply

1-43. Solve the following algebraic expression:

$$5x + 6y - c, \text{ when } c=4, x=3, \text{ and } y=2.$$

1. 23
2. 26
3. -23
4. -26

Solve the following equations:

1-44.  $4a^2b + 1a^2b = ?$

1.  $5a^4b^2$
2.  $5a^2b^2$
3.  $5a^2b$
4.  $5a^4b$

1-45.  $2b - [c + (c - 3a) - (9a - 5c)] = ?$

1.  $6a + 2b - 5c$
2.  $12a + 2b - 5c$
3.  $6a + 2b - 7c$
4.  $12a + 2b - 7c$

1-46.  $(4x + 6y) + (5x + 2y) = ?$

1.  $20x + 12y$
2.  $9x + 8y$
3.  $8x + 30y$
4.  $8x + 9y$

1-47.  $Cd(F + G - Y) = ?$

1.  $CdF + CdG + CdY$
2.  $CdF + CdG - CdY$
3.  $CDF + G + Y$
4.  $CDF + G - Y$

1-48.  $(3 + 2)(6 + 1) = ?$

1. 18
2. 27
3. 35
4. 41

1-49.  $(2x^2 - 1x - 9)(3x - 2) = ?$

1.  $6x^3 - 7x^2 - 25x + 18$
2.  $6x^2 - 7x - 7$
3.  $6x^3 - 7x - 25$
4.  $6x^2 + 7x + 25x - 18$

1-50.  $\frac{3ax + 2aBC + a}{a} = ?$

1.  $3x + 2BC$
2.  $3a^2x + 2a^2BC + a^2$
3.  $3X + 2BC + 1$
4.  $3a^2x + 2a^2BC + a^2 + 1$

## ASSIGNMENT 2

Textbook Assignment: "MATHEMATICS - APPLICATIONS," Pages 2-1 through 2-14.

---

- 2-1. An equation is an expression of equality.
1. True
  2. False
- 2-2. What is the fixed constant in the equation  $bx + 4y = c$
1.  $b$
  2.  $c$
  3.  $y$
  4. 4
- 2-3. Which of the following letters normally represents an arbitrary constant?
1.  $a$
  2.  $w$
  3.  $x$
  4.  $y$
- 2-4. What is the degree of the equation  $5x^2 - 3x + 1 = 0$ ?
1. First
  2. Second
  3. Third
  4. Fourth
- 2-5. What is the value of  $x$  in the equation  $x - 1 = 1$ ?
1. 0
  2. 1
  3. 2
  4. Not solvable
- 2-6. What is the value of  $y$  in the equation  $y/2 = 10$ ?
1. 10
  2. 20
  3. 5
  4. 2
- 2-7. What is the value of  $x$  in the equation  $2x + 6 = 18$ ?
1. 2
  2. 4
  3. 6
  4. 8
- 2-8. What is the value of  $y$  in the equation  $2y/2 + 4 = 10$ ?
1. 2
  2. 6
  3. 10
  4. 14
- 2-9. What is the value of  $x$  in the equation  $2x/6 + x = 12 - x$ ?
1.  $3^{6/7}$
  2.  $8/9$
  3. 12
  4. 24
- 2-10. In the equation  $x/c - a = b$ , what should you solve for?
1.  $a$
  2.  $b$
  3.  $c$
  4.  $x$
- 2-11. In a formula, the unknown quantity is in which of the following locations?
1. Right member
  2. Left member
  3. Both members
  4. Neither member
- 2-12. What is the subject in the formula  $E = IR$ ?
1.  $IR$
  2.  $I$
  3.  $R$
  4.  $E$
- 2-13. When two or more of the same letter are used, what is used to make distinction between them?
1. An asterisk
  2. A subscript
  3. A superscript
  4. A postscript
- 2-14. Manipulate the formula  $A = b/2h$  to solve for  $h$ .
1.  $h = 2A/b$
  2.  $h = 2b/A$
  3.  $h = A/2b$
  4.  $h = Ab/2$

- 2-15. The ratio 20 to 10 can be expressed as which of the following?
1. 20·10
  2. 20~10
  3. 20:10
  4. Both A and B
- 2-16. Which of the following quantities can be expressed as a ratio?
1. 6 ft:3 yd
  2. 2 yd:3 yd
  3. 3 yd:1 mile
  4. 4 oz:2 lb
- 2-17. Which of the following is the ratio of  $2\frac{1}{2}$  to 3 reduced to the lowest term?
1.  $\frac{2}{15}$
  2.  $\frac{15}{2}$
  3.  $\frac{5}{6}$
  4.  $\frac{6}{5}$
- 2-18. Which of the following refers to the second and third terms of a proportion?
1. Means
  2. Extremes
  3. Ratios
  4. Constants
- 2-19. In the proportion  $a/b = c/d$  the extremes are
1.  $a$  and  $c$
  2.  $a$  and  $d$
  3.  $c$  and  $b$
  4.  $d$  and  $c$
- 2-20. On a map having a scale of 1 in. to 50 mi., how many inches represent 540 mi.?
1. 8 in.
  2. 8.5 in.
  3. 10.8 in.
  4. 12 in.
- 2-21. The proportion  $x/2 = 9/16$  is equivalent to
1.  $9x = 8$
  2.  $9x = 32$
  3.  $16x = 9/2$
  4.  $16x = 18$
- 2-22. A change in one quantity which causes the same change in another quantity is what type of variation?
1. Joint
  2. Direct
  3. Inverse
  4. Constant
- 2-23. How many seconds does a chronometer lose in a week if it loses 9.0 seconds in 30 days?
1. 2.1 sec
  2. 2.4 sec
  3. 3.3 sec
  4. 3.8 sec
- 2-24. Which of the following is a situation in which  $x$  varies directly as  $y$ ?
1.  $x = 4/y$
  2.  $x = xy$
  3.  $xy = 6$
  4.  $x = 7y$
- 2-25. If  $x$  is directly proportional to  $y$  as in  $x = by$ , the expression  $b$  is called what?
1. Mean proportional
  2. Arbitrary proportional
  3. Third proportional
  4. Constant of proportionality
- 2-26. Which of the following expressions illustrates inverse variation?
1.  $x = ky$
  2.  $kx = y$
  3.  $x = k/y$
  4.  $x = k + y$
- 2-27. Which of the following is an example of joint variation?
1.  $A = LW$
  2.  $A = \pi r^2$
  3.  $C = 2\pi D$
  4.  $P = 4S$
- 2-28. In the Cartesian or rectangular coordinate system, the X and Y axes intersect at what angle?
1.  $0^\circ$
  2.  $45^\circ$
  3.  $60^\circ$
  4.  $90^\circ$

- 2-29. Which of the following is correct for describing a point with rectangular coordinates?
1.  $(X - Y)$
  2.  $(Y, X)$
  3.  $(X, Y)$
  4.  $(Y - X)$
- 2-30. What are the coordinates of the origin?
1.  $(1,1)$
  2.  $(0,0)$
  3.  $(1,0)$
  4.  $(0,1)$
- 2-31. What are the coordinates of a point located 3 units below the X axis and 7 units to the right of the Y axis in a Cartesian coordinate system?
1. Ordinate is 3, abscissa is 7.
  2. Ordinate is  $-3$ , abscissa is 7.
  3. Ordinate is 7, abscissa is  $-3$ .
  4. Ordinate is  $-7$ , abscissa is  $-3$ .
- 2-32. In a rectangular coordinate system, the point with coordinates  $(2, -1)$  is located in which quadrant?
1. First
  2. Second
  3. Third
  4. Fourth
- 2-33. In which quadrant are both the X and Y coordinates negative?
1. First
  2. Second
  3. Third
  4. Fourth
- 2-34. A linear equation with two variables has how many possible solutions?
1. One
  2. Two
  3. Four
  4. Infinite
- 2-35. The X coordinate of a point lying on the graph of the equation  $3x + y = 2$  is 9. What is the Y coordinate of the point?
1.  $-29$
  2.  $-25$
  3.  $-24$
  4.  $-21$
- 2-36. Which of the following pairs of coordinates are the coordinates of a point lying on the graph of the equation  $3y - 2x = -1$ ?
1.  $(-5, 2)$
  2.  $(1, -3)$
  3.  $(8, 6)$
  4.  $(11, 7)$
- 2-37. How many points do the graphs of the equations  $6x - 3y = 7$  and  $12x - 6y = 14$  have in common?
1. An infinite number
  2. 1
  3. 2
  4. None
- 2-38. Assume a line is drawn through the points with coordinates  $(-2, 10)$  and  $(5, -11)$ . Which of the following equations is the equation of that line?
1.  $x - 7 = -9$
  2.  $2x + 2y = 5$
  3.  $3x + y = 4$
  4.  $4x - 3y = 11$
- 2-39. What is the graph of the equation  $x = 0$ ?
1. The X axis
  2. The Y axis
  3. A horizontal line above the X axis
  4. A vertical line to the right of the Y axis
- 2-40. The graphical method of solving simultaneous equations is an exact method.
1. True
  2. False
- 2-41. In solving a pair of simultaneous linear equations by the addition method, you must first
1. add the two equations
  2. subtract one equation from the other
  3. make the coefficients of both variables the same in both equations
  4. make the coefficients of one of the variables the same, except for the sign, in both equations

2-42. One way to eliminate  $x$  from the equations  $3x + 2y = 6$  and  $5x + 7y = 43$  when solving by means of the addition method is to

1. multiply the first equation by 5 and the second equation by  $-3$
2. multiply the first equation by 3 and the second equation by 5
3. subtract the first equation from the second
4. subtract the second equation from the first

2-43. In eliminating  $y$  from the simultaneous equations  $2x + 7y = 3$  and  $3x - 5y = 31$  by the method of addition, the resulting equation is

1.  $5x = 34$
2.  $29x = 176$
3.  $31x = 232$
4.  $31x = 372$

2-44. The substitution method of solving simultaneous linear equations involves replacing one of the variables in one equation with

1. the variable's coefficient in the other equation
2. its value in terms of the other variable
3. the other equation
4. the constant from the other equation

2-45. In solving the equations  $2x - 3y = 4$  and  $x + 2y = 6$  by the substitution method, which of the following is a correct substitution of a variable from one equation into other?

1.  $x = 2y + 6$
2.  $x = 3y + 4$
3.  $y = \frac{4 - 2x}{-3}$
4.  $y = \frac{3 - x}{2}$

## ASSIGNMENT 3

Textbook Assignment: "PHYSICS - BASICS," Pages 3-1 through 3-20.

---

- 3-1. What unit of measurement is common to both the English and metric system?
1. Distance
  2. Force
  3. Mass
  4. Time
- 3-2. What is the metric basic unit of length (distance)?
1. Angstrom
  2. Micron
  3. Standard meter
  4. Kilometer
- 3-3. What is the English basic unit of length (distance) in the United States?
1. Yard (3600/3937 part of a standard meter)
  2. Foot
  3. Mile
  4. Inch
- 3-4. The mil is a measure of length equal to one-thousandth of what English system unit of measurement?
1. Inch
  2. Foot
  3. Yard
  4. Mile
- 3-5. When a body is compressed to a smaller volume, what quantity will always remain the same?
1. The mass of the body
  2. The energy of the body
  3. The temperature of the body
  4. The width of the body
- 3-6. A given object will weigh the most when the body is under which of the following conditions?
1. Compressed to a greater density and a smaller volume
  2. Expanded to a greater volume and a lesser density
  3. Located at one of the Earth's poles
  4. Located near the Earth's equator
- 3-7. What physical attribute is described by the metric units of dyne and newton?
1. Work
  2. Power
  3. Force
  4. Mass
- 3-8. What unit is combined with the unit of distance (nautical mile) to derive the knot?
1. Power
  2. Work
  3. Time
  4. Speed
- 3-9. Only if what condition exists may the term velocity be used in place of speed?
1. The motion of the body remains the same and is in a straight path in a given direction
  2. The unit of measurement is distance per hour for a given length of time
  3. The motion of the body is in a circular path following a given arc
  4. The unit of measurement is distance per second for a given length of time
- 3-10. The measurement of power involves what quantities?
1. Force and distance only
  2. Work and distance only
  3. Force, distance, and time
  4. Force, velocity, and time
- 3-11. Matter exists in three natural states. What are these three states?
1. Physical, chemical, and nuclear
  2. Electron, proton, and neutron
  3. Solid, liquid, and gas
  4. Fluid, porous, and vapor
- 3-12. What state or states of matter possess the property of porosity?
1. Liquid only
  2. Solid only
  3. Gas only
  4. Liquid, solid, and gas

- 3-13. Which of the following laws that help to predict physical phenomenon is reflected in the mathematical equation  $E=mc^2$ ?
1. Boyle's law
  2. Newton's law
  3. Charles' law
  4. Law of conservation of energy and matter
- 3-14. What mathematical calculation should you use to determine the specific gravity of a substance?
1. Divide the volume of the substance by its weight
  2. Divide the volume of the substance by an equal volume of water
  3. Take the reciprocal of the substance's density
  4. Divide the weight of the substance by the weight of an equal volume of water
- 3-15. To determine the kinetic energy of a moving body, what information must you know about the body in addition to the mass of the body?
1. Weight
  2. Velocity
  3. Friction
  4. Acceleration
- 3-16. A mass in motion is stopped. What happens to its kinetic energy?
1. It is converted into other forms of energy
  2. It is returned to the source that produced it
  3. It is increased by the amount necessary to stop the mass
  4. It is destroyed
- 3-17. An ion of an atom has which of the following properties?
1. No protons in its nucleus
  2. The ability not to attract other atoms
  3. A number of electrons not equal to the number of protons
  4. An overall neutral charge
- 3-18. What is an atom with an excess of electrons called?
1. A positive ion
  2. A negative ion
  3. An isotope
  4. A neutron
- 3-19. What is indicated by the atomic number of an element?
1. The total mass of one of its atoms
  2. The number of atoms that give the element its distinguishing characteristics
  3. The chronological order in which the element was discovered
  4. The number of protons in its nucleus
- 3-20. The mass, and consequently the weight, of an atom is contained almost entirely in what atomic structure or structures?
1. Nucleus
  2. Orbiting electrons
  3. Neutrons
  4. Electrons in the nucleus
- 3-21. Atoms of the same element that have different atomic weights are referred to by what term?
1. Compound
  2. Inert
  3. Isotope
  4. Element
- 3-22. When the outer shell of an atom is full, it is said to be what type of element?
1. Compound
  2. Isotope
  3. Solid
  4. Inert
- 3-23. What is the result of two elements that chemically combine with each other?
1. Compound
  2. Element
  3. Isotope
  4. Valence bond
- 3-24. Molecules are constantly in motion when they are in what physical state or states?
1. Gas only
  2. Liquid only
  3. Solid and liquid only
  4. Gas, solid, and liquid
- 3-25. Molecular attraction between like particles throughout a body (or the force that holds any substance or body together) is known by what term?
1. Malleability
  2. Adhesion
  3. Cohesion
  4. Ductility

- 3-26. Matter in what physical state exhibits tensile strength?
1. Gas only
  2. Solid only
  3. Liquid only
  4. Gas, solid, and liquid
- 3-27. Matter possesses the property of elasticity of compression when it is in what physical state or states?
1. Solid only
  2. Liquid only
  3. Gas only
  4. Solid, liquid, and gas
- 3-28. The condition when all molecular motion ceases and no additional heat can be extracted from the substance defines what physical condition?
1. Absolute zero
  2. Kelvin's zero
  3. Absolute temperature
  4. Temperature constant
- 3-29. Use Boyle's law. What would be the volume of a gas in a confined container if 30 cubic feet of the gas had its absolute pressure raised from 50 psi to 100 psi while a constant temperature was maintained?
1. 300 cubic feet
  2. 150 cubic feet
  3. 15 cubic feet
  4. 10 cubic feet
- 3-30. Use Charles' law. Approximately what would be the volume of gas in a confined container if 400 cubic feet of a gas at 10°C had its temperature raised to 60°C while a constant pressure was maintained?
1. 240 cubic feet
  2. 300 cubic feet
  3. 470 cubic feet
  4. 2,000 cubic feet
- 3-31. When a body is restricted so its rotation is about a point other than the center of gravity, the center of gravity revolves around what point?
1. The center of rotation
  2. A tangent
  3. The axis of revolution
- 3-32. Which of the following is a description of acceleration?
1. An act or process of a body changing its place or position
  2. A change in the body's speed or direction of travel
  3. A natural tendency of a body in motion to continue moving in a straight line
  4. An opposition of a body to changing its state of motion
- 3-33. The equations  $F = ma$  and  $a = F/m$  are mathematical forms of Newton's second law of motion. What relationship do they indicate?
1. The mass of a body depends upon the acceleration it is given
  2. The acceleration of a body depends upon the force acting on the body
  3. The force acting on a body depends upon the mass of that body
  4. The mass of a body depends upon the force acting on it
- 3-34. An automobile of a given mass traveling 40 mph has the same momentum as another automobile having twice the first automobile's mass traveling at what velocity?
1. 10 mph
  2. 20 mph
  3. 30 mph
  4. 40 mph
- 3-35. What name is given to the space through which action-at-a-distance forces are effective?
1. Force field
  2. Force space
  3. Vector force
  4. Contact force
- 3-36. The attractive force exerted on a body by the Earth is known by what term?
1. Weight
  2. Gravity
  3. Inertia
  4. Velocity
- 3-37. An object weighs exactly 1,000 kilograms (1,000 kg). What will the same object weigh 3,000 meters below sea level?
1. Exactly 1,000 kg
  2. More than 1,000 kg
  3. Less than 1,000 kg



A	Car A travels at 30 mph and turns a curve
B	Car B travels at 30 mph in one direction
C	Car C starts from a stop and reaches 40 mph
D	Car D slows from 60 mph to 15 mph

**Figure 3-A**

IN ANSWERING QUESTION 3-38, REFER TO FIGURE 3-A.

- 3-38. What car or cars experienced acceleration?
1. A only
  2. B only
  3. A, B, and C
  4. A, C, and D
- 3-39. What term is used to describe the reluctance of an object to change its speed, direction, or position of rest?
1. Acceleration
  2. Inertia
  3. Gravity
  4. Force
- 3-40. What is the quantitative measure of inertia?
1. Acceleration
  2. Density
  3. Mass
  4. Weight
- 3-41. A person lifts a 100-pound weight 3 feet and holds it for 5 seconds. What action or actions of the person constitute work?
1. Work is done by holding the weight steady for 5 seconds only
  2. Work is done by lifting the weight only
  3. Work is done in lifting the weight and holding it steady for 5 seconds
- 3-42. What amount of work is accomplished if a 50-pound weight is lifted 5 feet?
1. 10 foot-pounds
  2. 25 foot-pounds
  3. 250 foot-pounds
  4. 2,500 foot-pounds
- 3-43. For a body to possess kinetic energy, it must be in what condition?
1. Elevated from a position to which it can return
  2. Compressed from its natural condition
  3. At rest after work against a restoring force
  4. In motion

A	The contact of an airborne aircraft with the air
B	The use of brakes when an aircraft is landing
C	The action of rubbing two pieces of ice together

**Figure 3-B**

IN ANSWERING QUESTION 3-44, REFER TO FIGURE 3-B.

- 3-44. Friction is described in what instance or instances?
1. A only
  2. B only
  3. C only
  4. A, B, and C

A	Decreasing number of contact points
B	Using bearings whenever possible
C	Increasing number of contact points
D	Using lubricants

**Figure 3-C**

IN ANSWERING QUESTION 3-45, REFER TO FIGURE 3-C.

- 3-45. The effect of friction will be reduced by what action or actions?
1. A only
  2. A and B only
  3. A, B, and D only
  4. A, B, C, and D
- 3-46. When the mechanical advantage of a system is increased, what effect does the increase have upon the applied force?
1. Increases in proportion to the increase of mechanical advantage
  2. Acts over a greater distance to do the same work
  3. Requires less energy to do the same work
  4. Causes the load on the system to move a greater distance
- 3-47. With a revolving body, in what direction does (a) the centrifugal force and (b) the centripetal force act relative to the center of revolution?
1. (a) Away (b) toward
  2. (a) Toward (b) away
  3. (a) Away (b) away
  4. (a) Toward (b) toward

# ASSIGNMENT 4

Textbook Assignment: "PHYSICS - APPLICATION," Pages 4-1 through 4-28.

---

4-1. What theory(ies) are most commonly discussed regarding the nature of heat?

1. Radiation and convection
2. Convection and conduction
3. Conduction and kinetic
4. Kinetic and radiation

4-2. The theory of radiation of energy treats radio waves, heat, and light as the same general form of energy. What is the principle difference between these forms of energy?

1. Phase
2. Frequency
3. Polarity
4. Magnitude

4-3. Absorption is related to which of the following methods of heat transfer?

1. Convection
2. Radiation
3. Insulation
4. Conduction

4-4. The transfer of heat by the movement of hot fluid or gas is called what?

1. Kinetic
2. Radiation
3. Conduction
4. Convection

4-5. Emission of energy from the surface of a body is called what?

1. Radiation
2. Conduction
3. Convection
4. Polarization

4-6. Molecular energy passed by contact is called what?

1. Thermal radiation
2. Thermal conduction
3. Thermal kinetics
4. Thermal convection

- |   |
|---|
| <ol style="list-style-type: none"><li>A. It moves at the speed of light</li><li>B. It may pass through a medium without heating</li><li>C. It has the identical wavelength as radio waves and X-rays</li><li>D. It always travels in straight lines</li></ol> |
|---|

Figure 4-A

IN ANSWERING QUESTION 4-7, REFER TO FIGURE 4-A.

4-7. Transfer of heat by radiation has which of the following characteristics?

1. A only
2. B only
3. A, B, and C
4. A, B, and D

4-8. Which of the following attributes of a body make it a good absorber?

1. Highly polished
2. Light in color
3. Dark in color
4. Dense in concentration

4-9. What two temperature scales have their zero points corresponding to absolute zero?

1. Celsius and Fahrenheit
2. Kelvin and Rankine
3. Celsius and Kelvin
4. Fahrenheit and Rankine

4-10. When a thermometer reads 30°C, what is the temperature in Fahrenheit?

1. 0°F
2. 37°F
3. 86°F
4. 98.6°F

4-11. If a normal human body temperature is considered 98.6°F, what is the normal temperature on the Celsius scale?

1. 0°C
2. 37°C
3. 98.6°C
4. 100°C

- 4-12. What temperature scale is used for most scientific measurements?
1. Celsius
  2. Rankine
  3. Kelvin
  4. Fahrenheit
- 4-13. Adding 273 to a Celsius temperature reading converts the Celsius temperature to what temperature scale?
1. Rankine
  2. Fahrenheit
  3. Celsius
  4. Kelvin
- 4-14. Copper wires are not used for conductors through the glass envelopes of electron tubes for which of the following reasons?
1. Copper and glass have the same expansion rate
  2. Copper and glass have different expansion rates
  3. Copper has a positive coefficient of expansion and glass has a negative coefficient
  4. Copper has a negative coefficient of expansion and glass has a positive coefficient
- 4-15. The total increase in the size of an object when heated depends on the amount of temperature and which of the following factors?
1. Its original length only
  2. Its coefficient of expansion only
  3. Its length and coefficient of expansion
  4. Its average weight and coefficient of expansion
- 4-16. A steel plate 1 foot square has a 1 inch diameter hole through its center. What happens to the area of the hole when the plate is heated?
1. Decreases
  2. Increases
  3. Remains the same
- 4-17. What device uses the differences in coefficients of linear expansion of dissimilar metals to measure temperature?
1. Thermostat
  2. Thermograph
  3. Thermometer
  4. Thermocouple
- 4-18. What device operates on the principle that when two unlike metals are joined together they form a junction that produces an electromotive force, the temperature of which can then be measured with a galvanometer?
1. Thermostat
  2. Thermograph
  3. Thermometer
  4. Thermocouple
- 4-19. For each British thermal unit (Btu) of heat added to 1 pound of water, the temperature will increase by what amount?
1. 1°C
  2. 1°F
  3. 212°C
  4. 32°F
- 4-20. The action required to change a block of ice to water is known by the heat of what term?
1. Fusion
  2. Combustion
  3. Condensation
  4. Vaporization
- 4-21. The action to change water to gas is known as the heat of what term?
1. Fusion
  2. Combustion
  3. Condensation
  4. Vaporization

- |   |
|---|
| <p>A. Reflection</p> <p>B. Refraction</p> <p>C. Diffraction</p> <p>D. Compression</p> |
|---|

Figure 4-B

IN ANSWERING QUESTION 4-22, REFER TO FIGURE 4-B.

- 4-22. What are the common characteristics exhibited by all types of waves?
1. A and D only
  2. B and C only
  3. A, B, and C
  4. B, C, and D

- 4-23. The velocity of a wave depends on which of the following parameters?
1. Frequency of the wave
  2. Amplitude and disturbance within the wave
  3. Type of wave and the nature of the medium
  4. Distance of the crests between two adjacent waves
- 4-24. What term describes the distance along the direction of propagation of a wave between two successive points at precisely the same state of disturbance?
1. Velocity
  2. Frequency
  3. Intensity
  4. Wavelength
- 4-25. A single disturbance induced into a medium is known by what term?
1. Pulse train
  2. Wave train
  3. Wave pulse
  4. Wave
- 4-26. What term defines a wave when disturbance takes place at right angles to the direction of propagation?
1. Periodic
  2. Transverse
  3. Longitudinal
  4. Expansion
- A. Same type but different frequency traveling in the same direction

B. Same type but different frequency traveling in opposite directions

C. Same type and equal frequency traveling in the same direction

D. Same type and equal frequency traveling in opposite directions
- 4-27. A standing wave is produced by two wave trains and which other parameters?
1. A
  2. B
  3. C
  4. D
- 4-28. When a wave passes from one medium to another medium having a different velocity of propagation, the wave changes directions or bends and is referred to by what term?
1. Refraction
  2. Propagation
  3. Diffraction
  4. Compression
- 4-29. The size of the critical angle of refraction depends on the index of refraction of the two media, and the (a) the index of refraction, the (b) the critical angle of refraction becomes.
1. (a) Larger (b) larger
  2. (a) Larger (b) smaller
  3. (a) Smaller (b) larger
  4. (a) Smaller (b) smaller
- 4-30. What term refers to the bending of the path of waves around an obstruction?
1. Refraction
  2. Reflection
  3. Diffraction
  4. Compression
- 4-31. The most diffraction will usually occur at which frequency?
1. 100 Hz
  2. 1,000 Hz
  3. 10,000 Hz
  4. 100,000 Hz
- 4-32. Which of the following phenomena causes the Doppler effect?
1. Loss of energy within the wave due to absorption of the wave by the medium
  2. Interaction between two waves at the same frequency traveling in opposite directions in the same medium
  3. Relative motion between the wave source and the detector
  4. Interaction between two waves at the same frequency traveling in the same directions in a different medium
- 4-33. What is a substance that will transmit no light called?
1. Transparent
  2. Opaque
  3. Translucent
  4. Divergent

Figure 4-C

IN ANSWERING QUESTION 4-27, REFER TO FIGURE 4-C.

- 4-34. A flashlight is an example of what type of light waves?
1. Interference
  2. Reflection
  3. Refraction
  4. Diffraction
- 4-35. What unit of measurement is used to measure the intensity of incident light?
1. Watts
  2. Candela
  3. Foot-candle
  4. Candlepower
- 4-36. What unit of measurement is used to indicate the light a surface gives off in the direction of an observer?
1. Lambert
  2. Candela
  3. Lumen
  4. Foot-candle
- 4-37. What is a lens having a thicker center than edges called?
1. Positive or convergent lens
  2. Negative or divergent lens
  3. Positive or divergent lens
  4. Negative or convergent lens
- 4-38. The electromagnetic waves that produce light are located between infrared and ultraviolet radiation on the electromagnetic spectrum and have (a) frequencies and (b) wavelengths.
1. (a) High (b) short
  2. (a) High (b) long
  3. (a) Low (b) short
  4. (a) Low (b) long
- 4-39. In a given medium, which of the following factors determines the color of light?
1. The wavelength only
  2. The frequency only
  3. The speed of travel and the frequency
  4. The speed of travel and the wavelength
- 4-40. What colors are the primary frequencies of light?
1. Red, yellow, and green
  2. Blue, violet, and orange
  3. Red, green, and blue
  4. Yellow, violet, and orange
- 4-41. Which of the following factors have the greatest effect on sound velocity in a medium?
1. Temperature and altitude of the medium
  2. Frequency and amplitude of the sound waves
  3. Intensity and pitch of the sound waves
  4. Density and altitude of the medium
- 4-42. Sound waves travel faster in (a) than through (b).
1. (a) Air (b) water
  2. (a) Water (b) air
  3. (a) Air (b) hydrogen
  4. (a) Hydrogen (b) water
- 4-43. Which of the following are three characteristics of sound?
1. Tones, harmonics, and overtones
  2. Vibrations, compressions, and rarefactions
  3. Quality, intensity, and pitch
- 4-44. Sound waves above 20 kHz are referred to by which of the following terms?
1. Sonic
  2. Subsonic
  3. Audible
  4. Ultrasonic
- 4-45. Using the following formula:  $\text{dB} = 10 \times \log(P_2/P_1)$ , your result is a negative decibel value. What does the negative value indicate?
1. A loss in power
  2. A gain in power
  3.  $P_1$  is less than  $P_2$
  4. The values of  $P_2$  and  $P_1$  were transposed
- 4-46. The audio power output from a sound system would double if the sound intensity were increased by what amount?
1. 1 dB
  2. 3 dB
  3. 10 dB
  4. 30 dB

- A. Change the contours of the surface the sound is reflecting from
- B. Vary the amplitude or pitch of the stereo system
- C. Change the position of the stereo speakers
- D. Cover the surface with a material that reflects the sound

Figure 4-D

IN ANSWERING QUESTION 4-47, REFER TO FIGURE 4-D.

- 4-47. Which of the following changes would help decrease a considerable echo in a room with a stereo system and speakers?
- 1. A and C only
  - 2. B and D only
  - 3. A, B, and C
  - 4. A, C, and D

4-48. Sound is measured in what units?

- 1. Knots
- 2. Bels
- 3. Minutes
- 4. Meters

4-49. One milliwatt is equivalent to how many decibels?

- 1. 0 dBm
- 2. 1 dBm
- 3. 10 dBm
- 4. 11 dBm

4-50. Any disturbance, man-made or natural, that causes degradation to a wave is referred to by which of the following terms?

- 1. Resonance
- 2. Acoustics
- 3. Interference
- 4. Echo

# ASSIGNMENT 5

Textbook Assignment: "MAINTENANCE AND TROUBLESHOOTING," Pages 5-1 through 5-49.

---

- 5-1. Who is responsible for safety?
1. Commanding officer only
  2. Safety officer only
  3. Safety petty officer only
  4. All hands
- 5-2. Which publication contains an illustration of danger areas for an aircraft?
1. MIM
  2. MRC
  3. IPB
  4. PPB
- 5-3. When working with high voltage, you should
1. Work alone
  2. De-energize equipment
  3. Ground yourself
  4. Take measurements quickly
- 5-4. There is no danger when working with low voltage.
1. True
  2. False
- 5-5. Shock intensity is determined by which of the following?
1. Voltage
  2. Resistance
  3. Current
  4. Humidity
- 5-6. To remove a victim from electrical shock, which of the following should NOT be used?
1. Wooden cane
  2. Rope
  3. Circuit breaker
  4. Bare hands
- 5-7. What information, if any, should be etched on beryllium-copper tools?
1. Organization
  2. Work center
  3. Tool box
  4. None
- 5-8. At the local level, you may insulate tools for use on what types of circuits?
1. High-voltage
  2. Low-voltage
  3. Low-resistance
  4. High-resistance
- 5-9. When you find a damaged electrical tool cord, what action should you take?
1. Cover it with rubber tape
  2. Shorten the cord to remove the damaged part
  3. Repair the damage with insulating tape
  4. Replace the cord
- 5-10. While using an electric drill, you experience an electrical shock. Which of the following conditions is the most likely cause?
1. A voltage source that is too high
  2. A voltage source that is too low
  3. An incorrectly grounded drill
  4. An overloaded drill
- 5-11. What color is the safety ground wire for electrical tools?
1. Green
  2. White
  3. Black
  4. Red
- 5-12. When fighting an electrical fire, you should use which of the following fire-extinguishing agents?
1. Foam
  2. Water
  3. Soda and water
  4. Carbon dioxide
- 5-13. If you swallow gasoline, which of the following actions should you take?
1. Swallow three glasses of salt water to induce vomiting
  2. Drink large amounts of milk or water and take four tablespoons of vegetable oil if available
  3. Take two aspirins and two glasses of water
  4. Swallow a solution of bicarbonate of soda and water

- 5-14. Which of the following statements does NOT describe the hazards of compressed air?
1. It can inject minute foreign bodies into the skin
  2. It can rupture cell tissue and cause severe wounds
  3. It can pass through clothing and may cause fatal injury
  4. It can damage machinery moving parts
- 5-15. When using compressed air for blowing out fixtures and jigs, you should maintain pressure below what maximum value psi?
1. 10
  2. 20
  3. 30
  4. 40
- 5-16. Maintenance performed on equipment falls into what two broad maintenance categories?
1. I-level and O-level
  2. Scheduled and preventive
  3. Scheduled and unscheduled
  4. Unscheduled and corrective
- 5-17. Performing a visual check with the idea of avoiding malfunctions in the future is what type of maintenance?
1. Scheduled
  2. Unscheduled
  3. O-level
  4. I-level
- 5-18. PMS ensures equipment is maintained through its life cycle by controlling degradation from which of the following factors?
1. Time only
  2. Time and use only
  3. Time, use, and operational cycles only
  4. Time, use, operational cycles and climatic exposure
- 5-19. Finding a malfunctioning radar system during a preflight check falls into what maintenance category?
1. Scheduled
  2. Unscheduled
  3. O-level
  4. I-level
- 5-20. What is the greatest aid to a technician in troubleshooting malfunctioning systems?
1. Specified test equipment
  2. General purpose test equipment
  3. The replace-and-try system of equipment elimination
  4. Common sense
- 5-21. Before correcting a reported discrepancy, which of the following actions should you take?
1. Replace the faulty unit with one known to be good
  2. Determine that the discrepancy actually exists
  3. Get the maintenance instruction manual for the equipment in question
  4. Determine if power was applied when the discrepancy was discovered
- 5-22. In troubleshooting a discrepancy, you find the circuit breaker for that system is tripped. After checking it thoroughly, you find no apparent shorts. What should be your next action?
1. Reset the circuit breaker and apply power
  2. Remove the system for bench testing
  3. Replace the circuit breaker
  4. Remove the system, reset the circuit breaker, and reinstall the system one component at a time
- 5-23. If the usual checks and tests fail to isolate the faulty unit of a system, which of the following actions should you take?
1. Install a new system and use the removed units one at a time until the system malfunctions
  2. Send the system to AIMD for repair
  3. Replace system units one at a time until the system operates properly
  4. Inform the shop supervisor that a higher level of maintenance is required
- 5-24. Which of the following statements is NOT a basic rule you should observe when making tests?
1. Always connect ammeters in series and voltmeters in parallel
  2. When measuring dc voltages, observe polarity
  3. Always de-energize the circuit before you connect it to an ohmmeter
  4. Always use an ohmmeter scale that gives a full scale deflection



5-25. To check for an open circuit, what test should you conduct?

1. Grounded circuit
2. Short
3. Continuity
4. Voltage

5-26. When making voltage checks, where should you begin taking readings?

1. At the end of the circuit, working your way back
2. Midway in the suspected circuit
3. After the first stage of the faulty unit
4. At the source voltage

IN ANSWERING QUESTIONS 5-27 THROUGH 5-29, REFER TO FIGURE 5-2, AND SELECT THE PROPER TEST BEING DESCRIBED IN THE QUESTION.

5-27. Disconnect both test plugs from their respective units, then connect one lead of the ohmmeter to the suspected conductor and the other to the aircraft structure.

1. Continuity test
2. Grounded circuit test
3. Short test
4. Resistance test

5-28. Disconnect both circuit test plugs from their respective units, then connect one lead of the ohmmeter to one of the suspected conductors and the other lead to the suspect conductor.

1. Continuity test
2. Grounded circuit test
3. Short test
4. Resistance test

5-29. Disconnect both plugs from their units; connect one ohmmeter lead at one end of the cable and the other lead to the aircraft structure; at the opposite end of the cable, jump the conductor to the aircraft structure.

1. Continuity test
2. Grounded circuit test
3. Short test
4. Resistance test

5-30. A faulty radar indicator is to be repaired on the bench. Usually, the first step of the troubleshooting procedure is to

1. test each component separately
2. make continuity and resistance checks
3. make voltage checks
4. visually check the indicator for obvious defects

5-31. The probes of some test equipment have a capacitor in series with the input for the purpose of

1. creating an infinite ac impedance between the probes and the circuit under test
2. minimizing signal loss due to mismatched impedance between the probe and the circuit under test
3. preventing dc from the circuit under test from being applied to the test equipment
4. preventing ac from the test equipment from being applied to the circuit under test

5-32. If the input signal to an amplifier is set at 5 millivolts and the output measures 1.5 volts, what is the gain of the amplifier?

1. 300
2. 250
3. 150
4. 15

5-33. Test probes should not be shifted from one type of test equipment to another for what reason?

1. The probe resistance may be wrong for the equipment under test
2. The probe resistance may be wrong for the substitute test equipment
3. Voltage ratings of the probe may be exceeded
4. Unmatched connector shielding may result in erroneous readings

5-34. When voltage checks are made for comparison with a voltage chart, you should use a voltmeter having the same sensitivity as the meter used in making the chart for which of the following reasons?

1. Scale ranges will be the same on both meters
2. Circuit loading is eliminated
3. All voltage readings will be the same
4. The circuits will be loaded the same as when the chart was made, and the readings will be reliable

- 5-35. When troubleshooting faulty electronic equipment by observing the built-in meters, the technician is often able to
1. isolate faulty parts
  2. pinpoint the cause of the trouble
  3. isolate the faulty stage
  4. determine if the fault is a shorted capacitor, an open resistor, or a grounded wire
- 5-36. When an ohmmeter is used to check an electrolytic capacitor, what causes the pointer on the meter to indicate a higher resistance when the leads are reversed than it did when the leads were first applied?
1. When fully discharged, the capacitor's resistance is less than when charged
  2. The capacitor's voltage is of a polarity to oppose the ohmmeter's battery voltage
  3. When fully discharged, the capacitor's resistance is greater than when charged
  4. The capacitor's voltage adds to the ohmmeter's battery voltage
- 5-37. Under which of the following conditions should you take measurements for comparison with those in the maintenance instruction manual?
1. Under the same conditions as the noted readings
  2. All the controls of the control box counterclockwise
  3. The power switch to ON and all controls on the control box counterclockwise
  4. The power switch to ON and all the controls on the control box clockwise
- 5-38. Color coding is used for which of the following components
1. Resistors only
  2. Resistors and capacitors only
  3. Resistors, capacitors, and semi-conductor diodes only
  4. Resistors, capacitors, semi-conductor diodes, and transformers
- 5-39. What color codes identify a 100-ohm resistor with a 10 percent tolerance?
1. Brown, brown, black, gold
  2. Brown, black, brown, silver
  3. Black, brown, black, silver
  4. Brown, red, black, gold
- 5-40. What resistor value is represented by a color code of orange, black, and orange?
1. 3 K $\Omega$
  2. 30 K $\Omega$
  3. 300 K $\Omega$
  4. 3,000 K $\Omega$
- 5-41. To be classified as a cable, a single conductor must have which of the following characteristics?
1. Be insulated and designed to carry RF energy
  2. Be insulated and have a metallic braided shield
  3. Be covered by a metal shield and designed to carry FR energy
  4. Be covered by a metal shield and have at least a 00 wire size
- 5-42. When replacing aircraft electrical wire, what publication should you use to determine correct size and type of wire to use?
1. The aircraft MIM
  2. The aircraft IPB
  3. *Military Specifications, Wiring, Aerospace Vehicle*, SAE-AS50881
  4. *Installation Practices for Aircraft Electric and Electronic Wiring*, NA 01-1A-505
- 5-43. Which of the following can NOT be found in a wire identification code?
1. Circuit function
  2. Wire size
  3. Wire segment
  4. Wire length
- 5-44. Which of the following letters is NOT used to identify a wire segment?
1. E
  2. O
  3. X
  4. Z
- 5-45. In the wire identification code, what letter suffix identifies the wire acting as a ground?
1. G
  2. H
  3. N
  4. M

- 5-46. When stamping wires or cables, the distance between markings should not exceed what maximum distance?
1. 15 inches
  2. 10 inches
  3. 3 inches
  4. 6 inches
- 5-47. Heat-shrinkable tubing for wiring has which of the following advantages?
1. It insulates terminals only
  2. It waterproofs splices only
  3. It insulates terminals and waterproofs splices
  4. It replaces wire terminal covers
- 5-48. Before reusing items of mounting hardware, what determination should you make?
1. Whether they exceed the specification for their intended use
  2. That they are the same size and shape of the specified items
  3. If their weight and mechanical properties are correct
  4. That they are not damaged and if their reuse is prohibited
- 5-49. When should suitable substitute mounting parts be replaced?
1. During the next periodic inspection
  2. During the time the aircraft is at NADEP
  3. When the substitute parts become defective
  4. When the required parts become available
- 5-50. Which of the following considerations should you observe when substituting mounting parts?
1. Color
  2. Availability
  3. Magnetic properties
  4. Accessibility
- 5-51. What is the reason for moisture-proofing solder-type electrical connectors?
1. To reinforce the connector
  2. To reduce the possibility of the connector cracking
  3. To improve the connector's dielectric characteristics
  4. To protect the connector for future use
- 5-52. In addition to supporting and protecting electrical wires, what other advantage does conduit offer?
1. It protects against heat radiation
  2. It provides radio shielding
  3. It provides bullet deflection
  4. It supports adjacent cables
- 5-53. Shielded cable should be supported by the use of what type of clamp?
1. AN 742
  2. Strap
  3. Bonded
  4. Non-bonded
- 5-54. When long runs of cable between panels need to be supported, which of the following types of clamps is preferred?
1. AN 742
  2. Plastic
  3. Bonded
  4. Strap
- 5-55. When installing a cable through a lightening hole, you should use a grommet if the cable's distance from the edge of the hole is less than what minimum distance?
1.  $\frac{1}{4}$  inch
  2.  $\frac{3}{8}$  inch
  3.  $\frac{1}{2}$  inch
  4.  $\frac{5}{8}$  inch
- 5-56. The preferred method for attaching cable terminals to terminal blocks requires the use of what items of hardware?
1. An anchor nut and lock washer
  2. An anchor nut and flat washer
  3. A standard nut and lock washer
  4. A standard nut and flat washer
- 5-57. What type of safety wire should you use to prevent accidental activation of an emergency device?
1. Lock wire
  2. Seal wire
  3. Shear wire
  4. Soft steel wire

- 5-58. If an aircraft were improperly bonded, which of the following conditions would exist?
1. An increased chance of fire and a noisy radio receiver
  2. An increased chance of lightening strikes
  3. A decreased chance of lightening strikes
  4. An increased chance of electrical failures
- 5-59. A primary objective of bonding is to provide an electrical path of (a) dc resistance and (b) RF impedance.
1. (a) high (b) high
  2. (a) low (b) high
  3. (a) high (b) low
  4. (a) low (b) low
- 5-60. Which of the following is NOT an advantage of replaceable assemblies
1. Saves maintenance time
  2. Saves money
  3. Reduces weight
  4. Reduces material waste
- 5-61. Repair capability of an IMA is dependent on overcoming the lack of which of the following obstacles?
1. Time
  2. Personnel
  3. Space
  4. Money
- 5-62. ESD sensitive devices can be damaged or destroyed by what minimum voltage?
1. 10 volts
  2. 20 volts
  3. 30 volts
  4. 40 volts
- 5-63. The generation of static electricity on an object by rubbing is known as the
1. electrostatic charge
  2. dielectric effect
  3. triboelectric effect
  4. prime charge
- 5-64. Under which of the following conditions is generated static electricity decreased?
1. Dry air
  2. Humid air
  3. Cold air
  4. Hot air
- 5-65. Which of the following is NOT an ESD prime generator?
1. Synthetic mats
  2. Vinyl
  3. Common solder suckers
  4. Carbon impregnated polyethylene
- 5-66. What is the minimum resistance for personnel ground straps?
1. 25,000 ohms
  2. 150,000 ohms
  3. 250,000 ohms
  4. 500,000 ohms
- 5-67. What ESD protective material includes carbon-impregnated polyethylene and nylon?
1. Conductive
  2. Nonconductive
  3. Static
  4. Antistatic

# ASSIGNMENT 6

Textbook Assignment: "COMMON TEST EQUIPMENT," Pages 6-1 through 6-26.

---

- 6-1. Test equipment requiring calibration is compared to calibration standards of what accuracy?
1. Equal
  2. Higher
  3. Lower
- 6-2. Test equipment requiring calibration is forwarded to what work center?
1. Work center 620 at the IMA
  2. Work center 650 at the IMA
  3. Work center 670 at the IMA
  4. Production control or maintenance control, depending on the level of maintenance requiring calibration
- 6-3. Replacement of test equipment components can be performed by the end user for what components?
1. Test leads only
  2. An external fuse only
  3. Test leads, an external fuse, and a broken input power connector only
  4. Test leads, an external fuse, a broken power connector, and an internal fuse
- A. Use test equipment for its designed purpose

B. Select the proper range on test equipment for the quantity to be measured

C. Store test equipment in a clean, dry place when it is not being used
- 6-4. When handling test equipment, you should abide by what rule or rules?
1. A only
  2. A and B only
  3. B and C only
  4. A, B, and C
- 6-5. What is an advantage of using a digital multimeter over an analog multimeter?
1. Decreased human error
  2. Decreased instrument sensibility
  3. Decreased speed in which the measurement must be made, resulting in increased accuracy
  4. Simplified usage due to reduced number of output connectors
- 6-6. What determines the high frequency response of a DMM?
1. The sensitivity of the meter
  2. The shunt capacitance of the meter
  3. The resistance of the circuit being measured
  4. The shunt resistance of the meter
- 6-7. A true-rms meter is used to measure which of the following parameters?
1. Direct voltage
  2. Phase difference
  3. Inductance
  4. Square waves
- 6-8. When voltage measurements are made, the test leads of a DMM should be placed in what relationship to the circuit?
1. Parallel
  2. Series
- 6-9. High voltage probes are used in conjunction with a DMM when voltages exceed what specified potential?
1. 120 V
  2. 220 V
  3. 600 V
  4. 1000 V
- 6-10. When resistance measurements are made, the test leads of a DMM should be placed in what relationship to the component?
1. Parallel
  2. Series

**Figure 6-A**

IN ANSWERING QUESTION 6-4, REFER TO FIGURE 6-A.

- 6-11. When current measurements are made, the test leads of a DMM should be placed in what relationship to the circuit?
1. Parallel
  2. Series
- 6-12. What should be your first step when making current measurements to an energized circuit?
1. De-energize power to the DMM
  2. Connect the test leads to the circuit
  3. De-energize power to the circuit
  4. Select the proper current range on the DMM
- 6-13. When a DMM is used to perform a continuity test on a circuit, what does an audible beep indicate?
1. The circuit is open
  2. The circuit has voltage applied
  3. The circuit is above the resistance range of the DMM
  4. The circuit is closed
- 6-14. An ac voltmeter can have a scale that is calibrated for readings of which of the following indications?
1. Resistance
  2. Decibels
  3. Bandwidth
  4. Current leakage
- 6-15. A resistive device used only for dissipating power is referred to by what term?
1. Antenna
  2. Dummy load
  3. Waveguide
  4. Megohmmeter
- 6-16. What instrument measures very high resistance by applying high voltage to the component under test and measuring leakage of current through the component's insulation?
1. A volt-ammeter
  2. A volt-ohmmeter
  3. A megger
  4. A multimeter
- 6-17. Meggers are used to test the insulation resistance of which of the following conductors?
1. Power cables and high-voltage cables only
  2. High-voltage cables and transmission lines only
  3. Transmission lines and motor and generator windings only
  4. Power cables and high-voltage cables, transmission lines, and motor and generator windings
- 6-18. A megger consists of what total number of major components?
1. Five
  2. Two
  3. Three
  4. Four
- 6-19. When using a megger to test equipment, what safety precaution or precautions must a technician follow?
1. Discharge the equipment being tested before and after making the test
  2. Never energize the equipment while making the test
  3. Always use well-insulated test leads
  4. All of the above
- 6-20. When frequency is measured, a standard frequency source is required for making accurate comparisons. This frequency source is referred to by what term?
1. Counter
  2. Accumulator
  3. Time base
  4. Microprocessor
- 6-21. An electronic counter that measures the frequency of the input signal by counting the number of input cycles and dividing by the time interval is called a
1. Detector
  2. Reciprocal counter
  3. Reflectometer
  4. Conventional counter
- 6-22. What type of electronic counter always makes period measurements of the input signal first?
1. Reciprocal
  2. Absorption
  3. Conventional
  4. Multipath

- A. Ratio
- B. Bandwidth
- C. Totalize
- D. Pulse width

**Figure 6-B**

IN ANSWERING QUESTION 6-23, REFER TO FIGURE 6-B.

- 6-23. What functions are available on a typical electronic counter?
1. A and B only
  2. B, C, and D only
  3. A, C, and D only
  4. A, B, C, and D
- 6-24. Keeping an electronic counter connected to a power source when not being used achieves what purpose?
1. Maintains a stable oscillator
  2. Allows proper cooling requirements
  3. Reduces tuning errors
  4. Maintains a proper signal-to-noise ratio
- 6-25. With the channel C option installed on the model 5334 electronic counter it can measure frequencies accurately in what maximum frequency range?
1. 1.3 MHz
  2. 11.3 MHz
  3. 1.3 GHz
  4. 11.3 GHz
- 6-26. What function of an electronic counter is used when high-resolution and low-frequency measurements are made?
1. Ratio
  2. Period
  3. Totalize
  4. Time interval

- A. Thermocouple
- B. Diode
- C. Variactor
- D. Thermistor

**Figure 6-C**

IN ANSWERING QUESTION 6-27, REFER TO FIGURE 6-C.

- 6-27. What types of sensing elements are used in conjunction with power meters when measurements are performed?
1. A and D only
  2. B and C only
  3. A, B, and D
  4. B, C, and D
- 6-28. What type of power sensing device is based on the balanced bridge principle?
1. Thermocouple
  2. Diode
  3. Variactor
  4. Thermistor
- 6-29. The 436A power meter is used to measure power levels from  $-70$  dBm to what maximum range?
1.  $+132$  dBm
  2.  $+ 88$  dBm
  3.  $+ 44$  dBm
  4.  $+ 22$  dBm
- 6-30. What component of a 436A power meter determines the overall frequency and power range of the meter?
1. Reference switch position
  2. Analog peaking meter
  3. Sensor cable
  4. Power sensor

- A. Peak power
- B. Average power
- C. Watts
- D. Reference power

**Figure 6-D**

IN ANSWERING QUESTION 6-31, REFER TO FIGURE 6-D.

- 6-31. What functions are available on a 436A power meter?
1. A, B, and C
  2. A and C only
  3. B and D only
  4. B, C, and D

- 6-32. When the power sensor is referenced on a 436A power meter, what indication must be obtained on the digital readout?
1. 100.000 mW
  2. 10.000 mW
  3. 1.000 mW
  4. 0.000 mW
- 6-33. What is the principal use of the oscilloscope?
1. To measure microwave energy
  2. To visually examine waveforms
  3. To measure in-line power supply currents
  4. To locate the source of radio interference
- 6-34. In an oscilloscope, what waveform characteristics are represented by (a) vertical deflection and (b) horizontal deflection?
1. (a) Amplitude (b) time
  2. (a) Power (b) amplitude
  3. (a) Power (b) frequency
  4. (a) Time (b) amplitude
- 6-35. What type of oscilloscope can display any frequency within its range with equal stability, brightness, and clarity?
1. Digitizing storage
  2. Analog
  3. Digital phosphor
- 6-36. What type of oscilloscope allows the technician to capture and view signals that may occur only once?
1. Digitizing storage
  2. Analog
  3. Digital phosphor
- 6-37. What type of oscilloscope works by applying the measured signal voltage directly to an electron beam moving across the CRT?
1. Digitizing storage
  2. Analog
  3. Digital phosphor
- 6-38. What function of an oscilloscope is used to stabilize a repeating signal?
1. FOCUS
  2. POSITION
  3. HORIZONTAL COURSE
  4. TRIGGER
- 6-39. The frequency range of the analog oscilloscope is determined by what design feature?
1. CRT
  2. Microprocessor speed
  3. Horizontal section
  4. Sample rate
- 6-40. What type of oscilloscope uses parallel processing architecture to analyze varying signal levels in contrasting colors when desired by the technician?
1. Digitizing storage
  2. Analog
  3. Digital phosphor
- 6-41. Which of the following devices should be used to analyze modulated waves in the radio frequency and microwave region?
1. Distortion meter
  2. Spectrum analyzer
  3. Oscilloscope
  4. Wave meter
- 6-42. For which of the following tasks is a spectrum analyzer needed rather than an oscilloscope?
1. Analyzing a waveshape
  2. Measuring the elapsed time of a signal
  3. Measuring the amplitude of a signal
  4. Measuring power output of a transmitter
- 6-43. When a spectrum analyzer is used to display a modulated carrier wave for analysis, the carrier and sideband components are shown on a graph of voltage or power relative to frequency. The distribution of the frequencies on the graph is known by what term?
1. Spectrum
  2. Frequency displacement
  3. Phase displacement
  4. Frequency band
- 6-44. On a spectrum analyzer, what measurement information can be found on (a) the X-axis and on (b) the Y-axis?
1. (a) Voltage (b) current
  2. (a) Frequency (b) amplitude
  3. (a) Amplitude (b) frequency
  4. (a) Current (b) voltage



- 6-45. What block in a typical spectrum analyzer block diagram represents the components that deflect the CRT beam horizontally across the screen from left to right?
1. Detector
  2. Sawtooth generator
  3. IF amplifier
  4. Mixer
- 6-46. The 8562A/B-spectrum analyzer can accurately measure frequencies up to what maximum frequency without the use of an external mixer?
1. 22 GHz or below
  2. 22 GHz or above
  3. 32 GHz or below
  4. 32 GHz or above
- 6-47. The frequency range of the 8562A/B-spectrum analyzer can be extended to what maximum limit by the use of an external harmonic mixer?
1. 110 GHz
  2. 222 GHz
  3. 325 GHz
  4. 525 GHz
- 6-48. What standard CASS test station configuration is used for the testing of forward-looking infrared (FLIR) and laser range-finding components?
1. CNI
  2. Radio frequency
  3. Hybrid
  4. Electro-optics
- 6-49. What standard CASS test station configuration is the general-purpose station used for testing electrical/electronic equipment?
1. CNI
  2. Radio frequency
  3. Hybrid
  4. Electro-optics
- 6-50. What standard CASS test station configuration is used for the maintenance of communication and navigation equipment?
1. CNI
  2. Radio frequency
  3. Hybrid
  4. Electro-optics
- 6-51. What standard CASS test station configuration is used for the maintenance of electronic counter measure (ECM) equipment?
1. CNI
  2. Radio frequency
  3. Hybrid
  4. Electro-optics
- 6-52. What does the acronym CASS stand for?
1. Combined Avionics System Support
  2. Combined Automatic Support Subsystem
  3. Consolidated Aviation Subsystem Support
  4. Consolidated Automated Support System

